

Rosemount™ 326T Temperature Transmitter



The Rosemount 326T Temperature Transmitter is designed to provide accurate and repeatable temperature measurements in the food and beverage industry.

Emerson is here to optimize your food and beverage operations

The Rosemount 326T Temperature Transmitter ensures your process temperatures are always in specification

- Measuring Range: -58 to 302°F (-50 to 150°C)
- Wetted Materials: 316L SST Polished to Ra < 32 μ-in. (0.8 μ-m)
- Ingress Protection: IP69K
- Communication protocol: 4-20 mA, IO-Link



Emerson offers a broad portfolio of products to solve your toughest challenges

From simple measurements to critical applications, Emerson’s extensive portfolio of solutions has you covered. Our reliable, easy-to-use, and innovative products will help you to maximize production, maintain quality control and product consistency, minimize product losses, and assure the safety of your products.

Emerson offers a full service organization to give you the support you need



From simple repairs to complex projects, Emerson supports you with training and instrument services that improve the maintenance, reliability and performance of your products and, ultimately, your process equipment and production quality. We have a full organization of experienced and certified personnel. With both factory and regional service centers, we offer unmatched local support.

Contents

Emerson is here to optimize your food and beverage operations.....	2
Ordering information.....	3
Specifications.....	4
Product certifications.....	7
Dimensional drawings.....	8

Ordering information

Table 1: 326T Temperature Transmitter ordering information

The Standard offering represents the most common options. The starred options (★) should be selected for best delivery. The Expanded offering is subject to additional delivery lead time.

Model		
326T	Temperature transmitter	★
Immersion length		
L030	1.18 inches (30mm)	★
L050	1.97 inches (50mm)	★
L100	3.94 inches (100mm)	★
L150	5.91 inches (150mm)	★
L250	9.84 inches (250mm)	★
Process connection		
T32	1-1.5" Tri-Clamp	★
T42	2" Tri-Clamp	★
Housing material		
A	Stainless steel	★

Other options (include with selected model number)

Calibration certification		
Q4	Calibration certificate	
Material traceability certification		
Q8	Material traceability certificate	

Note

Optional options will not be included in the model string printed on the transmitter. For product reorder, make sure to include any desired optional options in the model string

Accessories and spare parts

These accessories are available for the Rosemount 326T Temperature Transmitter.

Cables and connectors

Description	Length	Part number
Hygienic Wireable Terminal Connector - M12 Female (angled) to Screw Terminals Operating voltage: < 250 AC / < 300 DC, Max current: 4A, Ambient temp: -13°F - 212°F (-25°C - 100°C), Screw Terminals: 23AWG - 17AWG 316L SST, gold plated contacts, EPDM sealing, IP69K	Wireable socket	FB-4000

Description	Length	Part number
Hygienic Cable - M12 Female (angled) to Flying Lead (4 x 22AWG) Operating voltage: <250 AC / <300 DC, Max current: 4A, Ambient temp: -13°F - 212°F (-25°C - 100°C), cULus approval limited to 149°F (65°C) 316L SST, gold plated contacts, EPDM sealing, IP69K	6.6 ft. (2 m)	FB-4002
	16.4 ft. (5 m)	FB-4005
	32.8 ft. (10 m)	FB-4010
	65.6 ft. (20 m)	FB-4020
	164 ft. (50 m)	FB-4050
Hygienic Patch Cable - M12 Female (angled) to M12 Male Operating voltage: < 250 AC / < 300 DC, Max current: 4A, Ambient temp: -13°F - 212°F (-25°C - 100°C), cULus approval limited to 149°F (65°C) 316L SST, gold plated contacts, EPDM sealing, IP69K	1.97 ft. (0.6 m)	FB-4106
	3.3 ft. (1 m)	FB-4101
	6.6 ft. (2 m)	FB-4102
	16.4 ft. (5 m)	FB-4105
	32.8 ft. (10 m)	FB-4110

Specifications

Functional specifications

Service

Liquid and gas applications

Measuring range

-58 to 302°F (-50 to 150°C)

Factory settings

4 mA: 0°F

20 mA: 300 °F

Temperature limits

Ambient

-13 to 176 °F (-25 to 80 °C)

Storage

-40 to 212 °F (-40 to 100 °C)

Max working pressure

1450 psi (100 bar)

Vacuum resistance

-14.5 psi (-1 bar)

Power supply

18 – 32 V DC (For cULus a Class 2 source required)

Current draw

<50 mA

Load limitation

300 Ω

Protection class

III

Output

In a two-wire configuration, the Rosemount 326T Temperature Transmitter provides a 4-20 mA analog output. In a three-wire configuration, digital IO-Link communication can also be utilized for increased transmitter functionality.

Resolution of analog output

≤ 0.072 °F (0.04 °C)

IO-Link

Transfer type: COM2 (38.4 kBaud)

IO-Link Revision: 1.1

Indication / Local Operator Interface

The Rosemount 326T comes standard with a seven-segment, four-digit LED display. The display also includes LED indicators to identify transmitter display units. The display units are configurable between °F and °C.

Resolution of display

0.5°F (0.28 °C)

Turn-on time

2 seconds

Physical specifications

Material selection

Emerson provides a variety of Rosemount™ products with various product options and configurations including materials of construction that can be expected to perform well in a wide range of applications. The Rosemount product information presented is intended as a guide for the purchaser to make an appropriate selection for the application. It is the purchaser's sole responsibility

to make a careful analysis of all process parameters (such as all chemical components, temperature, pressure, flow rate, abrasives, contaminants, etc.), when specifying product, materials, options and components for the particular application. Emerson is not in a position to evaluate or guarantee the compatibility of the process fluid or other process parameters with the product, options, configuration or materials of construction selected.

Measuring element

PT1000, DIN EN 60751, Class A

Process connections

- 1/1.5-inch tri-clamp
- 2-inch tri-clamp

Process wetted parts

316L SST (1.4435)

Surface finish: Ra < 32 μ-in. (0.8 μ-m)

Non-wetted parts

- 316L SST
- PEI
- FKM

Environmental seal for housing

Enclosures meet IP67, IP68, and IP69K ratings when properly installed

Electrical connection

The Rosemount 326T is equipped with an M12 Female electrical connector which features gold-plated contacts.

The wiring configuration sets the operating mode. After wiring the temperature transmitter, it automatically recognizes the connections and changes to the respective operating mode. Wiring configurations are shown in the following figure:

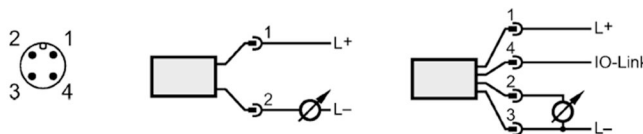

Shipping weights

Model String	Pounds	Grams
326TL030T32A*	0.73	330
326TL050T32A*	0.73	331
326TL100T32A*	0.75	342
326TL150T32A*	0.97	440
326TL250T32A*	0.73	332

Model String	Pounds	Grams
326TL030T42A*	0.83	375
326TL050T42A*	0.87	395
326TL100T42A*	0.88	399
326TL150T42A*	1.10	498

*Any option codes after the * do not impact shipping weight.

Performance specifications

Transmitter accuracy

$\pm 0.54 + (\pm 0.1\% \text{ span}) ^\circ\text{F}$

Dynamic performance

T05: 1 second

T09: 3 seconds

Ambient temperature effect

0.1% span per 18°F (10°C)

Vibration

The Rosemount 326T is tested to DIN EN 60068-2-6 and has a peak acceleration of 20 g in the frequency range 10 to 2000 Hz.

Electromagnetic compatibility

The Rosemount 326T meets the requirements of DIN EN 61000-6-2 and DIN EN 61000-6-3.

Product certifications

European directive information

The most recent revision of the EC Declaration of Conformity can be found at Emerson.com/Rosemount.

Ordinary location informaton

As standard, this product has been examined and tested to determine that the design meets the basic electrical, mechanical, and fire protection requirements by a nationally recognized test laboratory (NRTL) as accredited by the Federal Occupational Safety and Health Administration (OSHA).

Voltage supply to EN 50178, SELV, PELV / "supply class 2" to cULus.

3-A[®] certification

This product is authorized to display the 3-A symbol. Ensure gaskets and process connection accessories selected for installation meet both the application and 3-A requirements. A certificate of compliance is available at Emerson.com/Rosemount.

Other industry certifications

- (EC) No. 1935/2004
- (EC) No. 2023/2006
- CFR Title 21 (FDA) § 177.2600
- CFR Title 21 (FDA) § 177.2415

Dimensional drawings

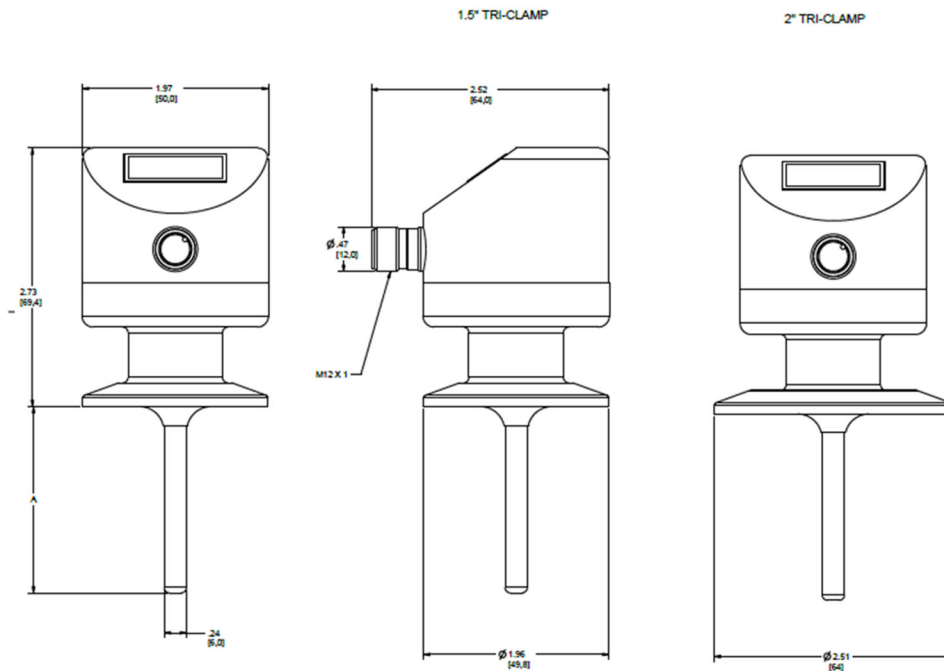

Immesion Length Option Code	Length A
L030	1.18 in. (30 mm)
L050	1.97 in. (50 mm)
L100	3.94 in. (100 mm)
L150	5.91 in. (150 mm)
L250	9.84 in. (250mm)

Global Headquarters

Emerson Automation Solutions
6021 Innovation Blvd.
Shakopee, MN 55379, USA

📞 +1 800 999 9307 or +1 952 906 8888
📠 +1 952 949 7001
✉️ RFQ.RMD-RCC@Emerson.com

Latin America Regional Office

Emerson Automation Solutions
1300 Concord Terrace, Suite 400
Sunrise, FL 33323, USA

📞 +1 954 846 5030
📠 +1 954 846 5121
✉️ RFQ.RMD-RCC@Emerson.com

Asia Pacific Regional Office

Emerson Automation Solutions
1 Pandan Crescent
Singapore 128461

📞 +65 6777 8211
📠 +65 6777 0947
✉️ Enquiries@AP.Emerson.com

North America Regional Office

Emerson Automation Solutions
8200 Market Blvd.
Chanhassen, MN 55317, USA

📞 +1 800 999 9307 or +1 952 906 8888
📠 +1 952 949 7001
✉️ RMT-NA.RCCRF@Emerson.com

Europe Regional Office

Emerson Automation Solutions Europe
GmbH
Neuhofstrasse 19a P.O. Box 1046
CH 6340 Baar
Switzerland

📞 +41 (0) 41 768 6111
📠 +41 (0) 41 768 6300
✉️ RFQ.RMD-RCC@Emerson.com

Middle East and Africa Regional Office

Emerson Automation Solutions
Emerson FZE P.O. Box 17033
Jebel Ali Free Zone - South 2
Dubai, United Arab Emirates

📞 +971 4 8118100
📠 +971 4 8865465
✉️ RFQ.RMTMEA@Emerson.com

 [Linkedin.com/company/Emerson-Automation-Solutions](https://www.linkedin.com/company/Emerson-Automation-Solutions)

 [Twitter.com/Rosemount_News](https://twitter.com/Rosemount_News)

 [Facebook.com/Rosemount](https://www.facebook.com/Rosemount)

 [Youtube.com/user/RosemountMeasurement](https://www.youtube.com/user/RosemountMeasurement)

 [Google.com/+RosemountMeasurement](https://plus.google.com/+RosemountMeasurement)

©2019 Emerson. All rights reserved.

Emerson Terms and Conditions of Sale are available upon request. The Emerson logo is a trademark and service mark of Emerson Electric Co. Rosemount is mark of one of the Emerson family of companies. All other marks are the property of their respective owners.