

SANITARY PRESSURE REDUCING VALVE P160

DESCRIPTION

The ADCA P160 series direct acting, spring-loaded, diaphragm sensing pressure reducing valves are designed for use with clean steam, compressed air, water and other gases or liquids compatible with the construction materials.

MAIN FEATURES

Compact design.
Completely machined from bar stock material, no castings or forgings are used on the standard version.
No rising stem.

STANDARD SURFACE FINISH

Internal wetted parts: ≤ 0,51 micron Ra – SF1.
External: ≤ 0,76 micron Ra – SF3.
Other surface conditions see IS PV20.00 E – Technical information.
Ultrasonic cleaning.

OPTIONS: Leakage line connection 1/8" (captured vent).
Different soft valves for liquids and gases.
Lock system, allows clean-in-place (CIP) and sterilization-in-place (SIP) operations with valve in line.
Gauge connection on body.
Adjusting screw with top cap.

USE: Clean steam, compressed air, water and other gases and liquids compatible with the construction.

AVAILABLE MODELS: P160.

SIZES: 3/4" to 2"; DN 20 to 50.

OUTLET SPRING RANGES: 0,8 – 1,5 bar; 1 – 3 bar; 1,5 – 5 bar.

CONNECTIONS: Clamp ferrules or others on request.

PACKAGING: Assembling and packaging in a clean room certified according to ISO 14644-1.
The product is end capped and sealed with recyclable thermo-shrinkable plastic film, to avoid contamination.

INSTALLATION: Horizontal installation. Inlet vertical and horizontal outlet angle connection. See IMI.

ORDER REQUIREMENTS: Type of fluid.
Maximum operating temperature.
Inlet pressure and required outlet pressure.
Capacity (maximum and minimum).

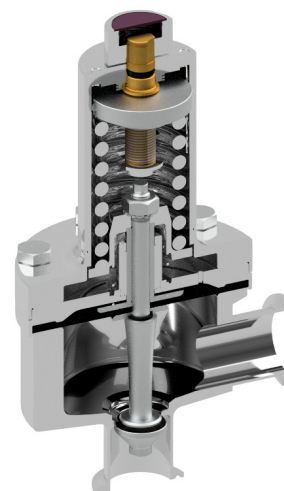

LIMITING CONDITIONS	
Valve model	P160
Body design conditions	PN16
Max. upstream pressure	8 bar 4 bar *
Max. downstream pressure	5 bar
Min. downstream pressure **	0,8 bar
Max. design temperature ***	150 °C

* See capacity table.

** For tight shut off, with regulating spring relaxed, ensure a minimum 0,2 bar downstream pressure.

*** Others on request.

CE MARKING – GROUP 2 (PED – European Directive)	
PN16	Category
3/4" to 2"; DN 40 to 50	SEP

DIMENSIONS (mm) ASME BPE

SIZE	Kvs	A	B	C	D	d1 *	d2 *	E *	F	H	WGT. (kg)
3/4"	1,3	85	56	192	130	25	15,75	89	25	15,75	6,7
1"	3,5	85	55	192	130	25	15,75	89	50,5	22,1	6,8
1 1/2"	5,5	85	65	199	130	25	15,75	89	50,5	34,8	7,6
2"	5,5 **	85	69	205	130	25	15,75	89	64	47,5	7,8

* Optional.

** 8,5 when limited to a maximum 4 bar inlet pressure.

DIMENSIONS (mm) DIN

SIZE	Kvs	A	B	C	D	d1 *	d2 *	E *	F	H	WGT. (kg)
DN 20	1,3	89	62	192	130	25	15,75	89	34	20	6,6
DN 25	3,5	92	64	192	130	25	15,75	89	50,5	26	6,5
DN 40	5,5	92	75	199	130	25	15,75	89	50,5	38	7,2
DN 50	5,5 **	92	75	205	130	25	15,75	89	64	50	7,6

* Optional.

** 8,5 when limited to a maximum 4 bar inlet pressure.

DIMENSIONS (mm) ISO

SIZE	Kvs	A	B	C	D	d1 *	d2 *	E *	F	H	WGT. (kg)
DN 20	1,3	81	49	192	130	25	15,75	89	50,5	23,7	6,5
DN 25	3,5	81	51	192	130	25	15,75	89	50,5	29,7	6,4
DN 40	5,5	92	80	199	130	25	15,75	89	64	44,3	7,7

* Optional.

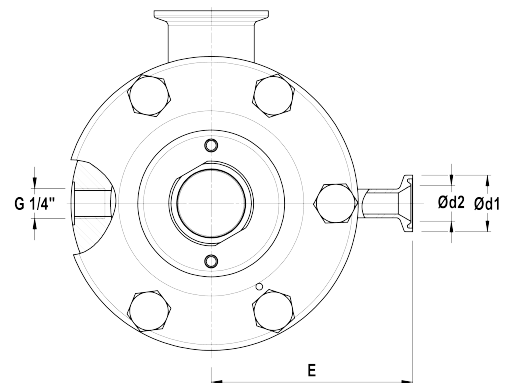
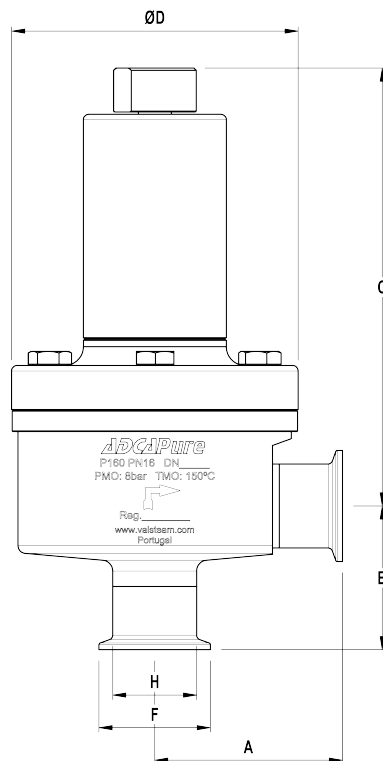

MATERIALS		
POS. N°	DESIGNATION	MATERIAL
1	Valve body	AISI 316L / 1.4404
2	Cover	AISI 316L / 1.4404
3	Centering plate	AISI 316L / 1.4404
3A	*** O-ring	EPDM
4	* Valve stem	AISI 316L / 1.4404
5	* Soft plug	** EPDM; PTFE
6	* Valve plug	AISI 316L / 1.4404
7	* Upper diaphragm	EPDM
8	* Lower diaphragm	PTFE (Gylon)
9	Diaphragm plate	AISI 316L / 1.4404
10	* O-ring	EPDM
11	Diaphragm plate	AISI 316L / 1.4404
12	Stem guide	AISI 316 / 1.4401
12A	Plain bearing	Bronze
12B	Spring	AISI 302 / 1.4300
13	Spring plate	AISI 316 / 1.4401
14	Nut	Stainless steel A2-70
15	Washer	AISI 316 / 1.4401
16	* Adjustment spring	AISI 302 / 1.4300
17	Top spring plate	AISI 316 / 1.4401
18	Retaining washer	Stainless steel A2-70
19	Regulating nut	AISI 316L / 1.4404
20	Adjusting screw	Brass
21	O-ring	NBR
22	Bearing	Corrosion resistant steel
23	Ext. bowed shaft ring	Stainless steel
24	Cover nut	Plastic
25	Bolts	A2

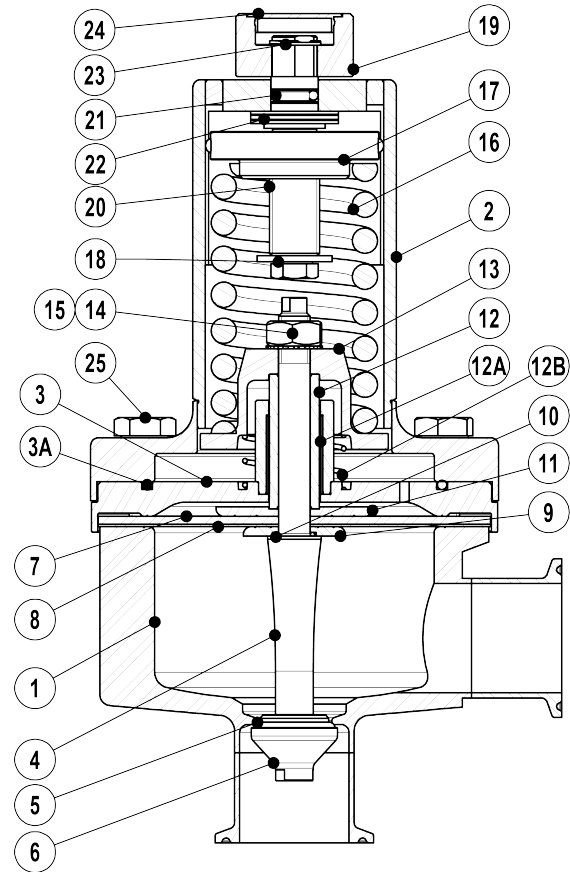

* Available spare parts ; ** Others according to fluid;

*** Applied only with leakage line option.

Remarks: FDA / USP Class VI seals certificate on request.

All valves have a serial number. In case of non-standard valves, this number must be supplied if spare parts are ordered.

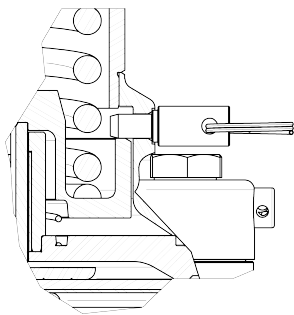
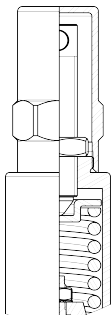
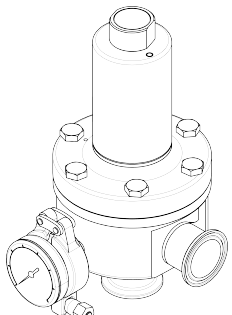
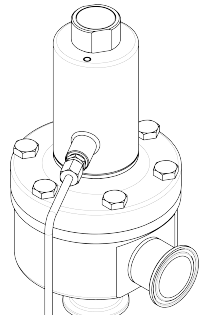
OPTIONS			
LOCK SYSTEM	ADJUSTING SCREW W/ TOP CAP	PRESSURE GAUGE CONNECT.	LEAKAGE LINE CONNECTION
			

ORDERING CODES P160														
Valve model	P16	4	1	T	M	I	X	X	X	D	20	E		
P160 – AISI 316L / 1.4404 diaphragm sensing pressure reducing valve	P16													
Outlet spring range														
0,8 to 1,5 bar		4												
1 to 3 bar		5												
1,5 to 5 bar		6												
Flow capacity														
Kvs – 1,3 (3/4")				1										
Kvs – 3,5 (1")				3										
Kvs – 5,5 (1 1/2" – 2")				4										
Kvs – 8,5 (2" limited to max. 4 bar inlet pressure.)				6										
Diaphragm material														
PTFE (Gylon)					T									
Valve head														
Metal to metal (non standard)						M								
EPDM							E							
PTFE								T						
FPM / Viton									V					
Regulating knob, top cap and captured vent														
Stainless steel regulating knob										I				
Top cap (adjusting screw sealing)											T			
Stainless steel regulating knob w/ diaphragm cover leakage connection in case of diaphragm failure												L		
Top cap (adjusting screw sealing) w/ diaphragm cover leakage connection in case of diaphragm failure													U	
Gauge port options														
Without gauge ports													X	
Tri-clamp gauge port on the left side (rel. to the flow direction) – downstream pressure														7
Tri-clamp gauge port on the right side (rel. to the flow direction) – downstream pressure														6
Tri-clamp gauge port on both sides – downstream pressure														5
Threaded gauge port on the left side (rel. to the flow direction) – downstream pressure – ISO 7 Rp 1/4"														4
Threaded gauge port on the right side (rel. to the flow direction) – downstream pressure – ISO 7 Rp 1/4"														3
Threaded gauge port on both sides – downstream pressure – ISO 7 Rp 1/4"														2
Threaded gauge port on the left side (rel. to the flow direction) – downstream pressure – 1/4" NPT														W
Threaded gauge port on the right side (rel. to the flow direction) – downstream pressure – 1/4" NPT														Y
Threaded gauge port on both sides – downstream pressure – 1/4" NPT														Z
Surface finish (a)														
Standard surface finish														X
Mirror mechanical polished external surfaces (SF1)														P
Electropolished internal wetted parts (SF5)														E
Special features														
None														X
Degreased for oxygen														O
CIP / SIP lock system														C
Pipe connections														
Clamp ferrule ASME BPE														D
Clamp ferrule DIN (DIN 32676-A)														F
Clamp ferrule ISO (DIN 32676-B)														E
ETO according to ASME BPE														DI
ETO according to DIN 11866-A (DIN 11850-2)														FI
ETO according to ISO 1127-1														EI
Size														
3/4" or DN 20														20
1" or DN 25														25
1 1/2" or DN 40														40
2" or DN 50														50
Special valves / Extras														
Full description or additional codes have to be added in case of a non-standard combination														E

a) Consult IS PV20.00 (Technical information) for further details and other surface finish options.