

62 SERIES

3-18 Round Cartridge Housings



The **62 Series** Multi cartridge housing range is designed to accommodate 3, 5, 7, 10, 12, 15, or 18 stacks of filter cartridges up to 40" long. The top opening style is equipped with a Cast Vee clamp as standard for pressures ranging from 7 - 10 bar g. Leg mounted and equipped with the more conventional dished end, these housings suit processes where there is a need to allow complete drainage of the clean chamber. This design assists in maintaining the general cleanliness of the process system. With the ability to accept both standard Double Open End and Single Open End cartridges, this leg mounted, free standing housing will suit most applications. Bolted closures are an option available for all models.



The **62 Series** will accept the full range of Amazon and industry standard cartridges ranging from 0.1 to 500µm with nominal lengths of 10, 20, 30 and 40".

For information on housings suitable for 19, 22, 24, 30 and 40 cartridges refer to datasheet '62 Series - 19-40 Round Cartridge Housings'.

Note: 6207, 12 & 18 only accept 66.5mm maximum diameter cartridges.

Product Features:

- Dished bottom end allows complete drainage of clean chamber, leading to improved system cleanliness
- Adjustable strap legs on the 3 and 5 round housings allow the user to set inlet and outlet heights
- Vee clamp closures use unique 'W' style seal for reliable leak free operation
- High quality cast Vee band clamps for safety and security
- Cast compression nut with integral PTFE washer for easy, hand tight cartridge sealing
- Wide range of connection sizes and types, cartridge lengths and materials of construction
- PED and ATEX Compliant
- WRAS Approved product

Accessories	Part Number
Pressure Gauge and Vent Valve Kit 	60S000016
Pressure Gauge and Auto Vent Valve Kit 	60S000082
Ball Valve and Nipple 	60S000010



Features and Benefits

- Integral vent, clean and dirty drains to aid efficient filter change-out
- Each housing hydrostatically pressure tested
- Internally and externally electropolished as standard
- Each housing is etched with a unique serial number for full traceability
- Full housing customisation service available
- Universal cup enables choice of plug in (Code 3 and Code 8) or DOE cartridge styles in the same housing
- WRAS Approved product

Product Range

Amazon Filters design and manufacture an extensive range of liquid filtration systems, providing one of the widest selections of filtration vessels, depth filters and pleated cartridges available today, ensuring excellent process and filter compatibility. As one of Europe's leading manufacturers of filtration systems, Amazon Filters is able to offer a solution to meet all filtration requirements. Amazons' filters are manufactured in clean room conditions and all products come with detailed Product Validation Guides and Technical Support documentation.



AMAZON

62 Series Technical Data

Max Operating Conditions

	6203	6105/7	6210/12	6215/18
Liquid: Vee clamp:	10 bar g	10 bar g	10 bar g	7 bar g
Bolted closure:	FV / 10 bar g	FV / 10 bar g	FV / 10 bar g	FV / 10 bar g
Gas: Vee clamp:	7.5 bar g	4.5 bar g	2 bar g	1.5 bar g
Bolted closure:	FV / 7.5 bar g	FV / 4.5 bar g	FV / 2 bar g	FV / 1.5 bar g
Temperature Range:	-10°C / 150°C			

Materials of Construction

Body:	316L St.Steel
Closure:	Vee Clamp - 304 St.Steel Screw Clamp - Zinc plated carbon steel (Optional Stainless Steel)
Vessel Finish:	Electropolished

Connections

	6203-05-07	6210-12	6215-18
Inlet / Outlet:	2" BSPM	3" BSPM	4" BSPM
Vent:	¼" BSPM	¼" BSPM	½" BSP
Drain:	½" BSPM	½" BSPM	1" BSPM

PED Status:

Fluid Groups: Compliant with 2014/68/EU
Liquids Group 1 + 2
Gas Group 2

Marking: CE

Exceptions: Group 1 liquids - Explosive

ATEX:

Compliant with 2014/34/EU, level CE Ex II 2 GD c X

Technical drawings for each individual housing showing dimensions, volume, weights, maximum temperatures and design pressures available on request.

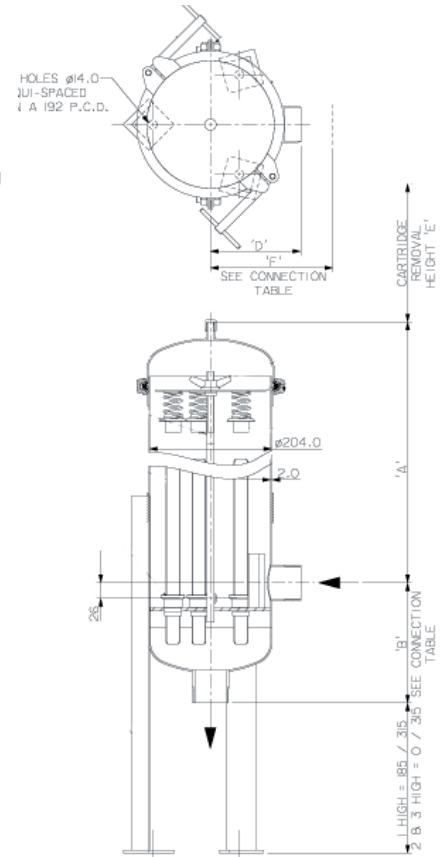

AMAZON FILTERS LTD.

Albany Estate, Camberley, Surrey, GU16 7PG, ENGLAND

Tel: +44 (0) 1276 670 600 Email: sales@amazonfilters.co.uk Web: www.amazonfilters.com