

# Rosemount™ 3051S Series of Instrumentation



## Innovation reaching across your operation

With the Rosemount 3051S Series of Instrumentation, operations can be optimized in these critical areas: production, quality, energy efficiency, and safety and environment. By leveraging the power of the scalable Rosemount 3051S across the entire operation, you'll be able to minimize process variability, gain greater process insight, reduce maintenance and downtime, and meet regulatory demands. What's more, it's easy to use, ensuring the full potential of the measurement investment is realized.

# Overview

## Rosemount 3051S SuperModule™ Platform

### The most advanced pressure, flow, and level measurements



- The all-welded hermetic SST design delivers the industry's highest field reliability.
- Ultra performance provides up to ±0.025 percent accuracy and 200:1 rangedown.
- Ultra for Flow performance provides up to ±0.04% of reading and 14:1 flow turndown.
- 15-year stability and 15-year limited warranty
- SIL3 Capable: IEC 61508 certified by an accredited third-party agency for use in safety instrumented systems up to SIL 3 (minimum requirement of single use [1oo1] for SIL 2 and redundant use [1oo2] for SIL 3).
- IEC 61508 Functional Safety Specifications for 3051S are detailed at [Emerson.com/Rosemount/Safety](http://Emerson.com/Rosemount/Safety).

---

## Contents

Overview.....	2
Rosemount 3051S Coplanar Pressure Transmitter.....	7
Rosemount 3051S In-line Pressure Transmitter.....	21
Rosemount 3051S MultiVariable™ Transmitter.....	31
Rosemount 3051SF DP Flow Meters.....	45
Rosemount 3051S Electronic Remote Sensor (ERS™) System.....	87
Rosemount 3051S Scalable™ Level Transmitter.....	108
Diaphragm seals for Rosemount 3051SAL.....	122
Specifications.....	138
Product certifications .....	169
Dimensional drawings.....	197
Accessories.....	211

## Rosemount 3051S Series selection guide

### Rosemount 3051S Coplanar™ Differential, Gauge, or Absolute Transmitter



Ordering information: [Rosemount 3051S Coplanar Pressure Transmitter](#)

- Coplanar platform enables integrated manifold, primary element, and seal system solutions.
- Dual-capacitance Saturn™ sensor technology corrects for overpressure and line pressure effects.
- Calibrated spans from 0.1 inH<sub>2</sub>O to 4000 psi (0.25 mbar to 276 bar).
- Available with 316L SST, Alloy C-276, Alloy 400, Tantalum, gold-plated Alloy 400, or gold-plated 316L SST process isolators

### Rosemount 3051S In-line Gauge or Absolute Transmitter



Ordering information: [Rosemount 3051S In-line Pressure Transmitter](#)

- Direct threaded connection, manifold or seal system solutions
- Piezoresistive sensor technology allows calibrated spans from 0.3 to 10000 psi (20.7 mbar to 689 bar).
- Available with 316L SST or Alloy C-276 process isolators

### Rosemount 3051S MultiVariable™ Transmitter



Ordering information: [Rosemount 3051S MultiVariable™ Transmitter](#)

- Combines Differential Pressure, Static Pressure, and Process Temperature measurements along with Mass and Energy Flow in a single device.
- Compensates for 25+ different variables providing accurate and repeatable flow readings.
- Customize pressure and temperature compensation for any flow application.
- Easily configure flow and device parameters with Engineering Assistant Software.

### Rosemount 3051SF DP Flow Meters



Ordering information: [Rosemount 3051SF DP Flow Meters](#)

- Integrates the Rosemount 3051S with Rosemount's industry leading primary elements to create one complete flow meter assembly.
- Fully assembled, configured and leak tested for out-of-the-box installation.
- Reduce installed costs by replacing ten parts traditionally used for a DP Flow installation with one flow meter.
- Reduce straight pipe requirements, lower permanent pressure loss, and achieve accurate measurement in small line sizes.

### Rosemount 3051S Electronic Remote Sensor (ERS™) System



Rosemount 3051SAM Transmitter Ordering information: [Rosemount 3051SAM Transmitter for ERS Applications](#)

Rosemount 3051SAL Transmitter Ordering information: [Rosemount 3051SAL Transmitter for ERS Applications](#)

- The industry's first digital DP Level architecture consists of a single 4–20 mA HART® loop with two Rosemount 3051S pressure sensors connected electronically.
- Unique digital architecture enables stable and repeatable DP Level measurements on tall vessels, towers, and applications with wide-varying temperatures.
- Achieve increased process insight and diagnostics with multivariable measurements including DP, pressure, and scaled variable for tank level or volume.
- Simplify installations and maintenance by eliminating wet or dry legs, heat tracing, and purge systems.

### Rosemount 3051S Level Transmitter



Ordering information: [Rosemount 3051S Scalable™ Level Transmitter](#)

- Level transmitters combine world-class Rosemount 3051S Pressure Transmitters with direct mount seals, all in a single integrated model number.
- Connect to virtually any process with a comprehensive offering of seal types, sizes, fill fluids, and diaphragm materials.
- Combine with an Rosemount 1199 Remote Mount Seal to form a Tuned-System™ Assembly for a cost effective, easy-to-install DP Level measurement solution.



## Advanced functionality

### WirelessHART® (IEC 62591) capabilities



The following functionality is available on coplanar, in-line, multivariable, DP flow meters and level transmitters:

- Quickly deploy new pressure, level and flow measurements in 70 percent less time.
- Eliminate wiring design and construction complexities to lower costs by 40–60 percent.
- Reduce pipe penetrations and impulse piping with industry-leading multivariable technology.
- Extended range antenna capabilities provide access to remote locations.
- Delivering more than a decade of maintenance free performance with 15-year stability and 10-year power module life.

### Advanced diagnostic capabilities



The following functionality is available on coplanar, in-line, DP flow meters, and level transmitters:

- Provides diagnostic coverage from the process to the transmitter to the host.
- Prevent on-scale failures by diagnosing electrical loop issues with loop integrity diagnostics.
- Process intelligence detects abnormal process conditions enabling more productive and safer operations.
- Monitor for solids build-up or freezing in the process connection with the plugged impulse line diagnostic.
- Extend diagnostic coverage to Safety Instrumented Systems with IEC 61508 SIL 2/3 capable rating.

### Remote display and interface



The following functionality is available on coplanar, in-line, DP flow meters, Electronic Remote Sensors, and level transmitters:

- Direct mount to the process and access transmitter capabilities and diagnostics at grade.
- Get access up to 100 ft. (30 m) away from the process to ensure personnel safety.
- Eliminate the need for impulse lines for best practice installations.

## Rosemount instrument manifolds



Available on traditional, coplanar, and in-line transmitters:

- Designed and engineered to provide optimal performance with Rosemount 3051S Transmitters.
- Reduce cost and leak points with flangeless coplanar design.
- Fully integrated manifold and transmitter assemblies come fully leak-checked, calibrated, and assembled allowing for one purchase order to save time and cost.
- Rosemount manifolds provide a wide variety of styles, materials, and configurations to fit any process.

## Access information when you need it with asset tags

Newly shipped devices include a unique QR code asset tag that enables you to access serialized information directly from the device. With this capability, you can:

- Access device drawings, diagrams, technical documentation, and troubleshooting information in your MyEmerson account
- Improve mean time to repair and maintain efficiency
- Ensure confidence that you have located the correct device
- Eliminate the time-consuming process of locating and transcribing nameplates to view asset information

# Rosemount 3051S Coplanar Pressure Transmitter



Rosemount 3051S Coplanar Pressure Transmitters are the industry leader for Differential, Gauge, and Absolute pressure measurement. The coplanar platform allows seamless integration with manifolds, primary elements, and seal solutions. Capabilities include:

- Ultra, Ultra for flow, and classic performance
- 4–20 mA HART®, WirelessHART®, FOUNDATION™ Fieldbus protocols
- Safety Certification (Option code QT)
- Advanced diagnostics (Option code DA2)
- Remote display and interface (Option code M7, M8, or M9)

<a href="#">CONFIGURE &gt;</a>	<a href="#">VIEW PRODUCT &gt;</a>
--------------------------------	-----------------------------------

## Online product configurator

Many products are configurable online using our Product Configurator. Select the **Configure** button or visit our [website](#) to start. With this tool's built-in logic and continuous validation, you can configure your products more quickly and accurately.

## Specifications and options

See the Specifications and options section for more details on each configuration. Specification and selection of product materials, options, or components must be made by the purchaser of the equipment. See the Material selection section for more information.

## Model codes

Model codes contain the details related to each product. Exact model codes will vary; an example of a typical model code is shown in [Figure 1](#).

**Figure 1: Model Code Example**

**3051C D 2 X 2 2 M5 B4**

1            2

1. Required model components (choices available on most)
2. Additional options (variety of features and functions that may be added to products)

## Optimizing lead time

The starred offerings (★) represent the most common options and should be selected for best delivery. The non-starred offerings are subject to additional delivery lead time.

## Required model components

### Model

Code	Description	
3051S	Scalable pressure transmitter	★

### Performance class

Code	Description	
1	Ultra: 0.025% span accuracy, 200:1 rangedown, 15-year stability, 15-year limited warranty	★
3 <sup>(1)</sup>	Ultra for Flow: 0.04% reading accuracy, 200:1 turndown, 15-year stability, 15-year limited warranty	★
2	Classic: 0.035% span accuracy, 150:1 rangedown, 15-year stability	★

(1) This option is only available with range codes 2A and 3A, 316L SST or Alloy C-276 isolating diaphragm and silicone fill fluid.

### Connection type

Code	Description	
C	Coplanar	★

### Measurement type

Performance class code 3 is available with measurement type code D only.

Code	Description	
D	Differential	★
G	Gauge	★
A	Absolute	

### Pressure range

Code	Description			
	Differential	Gauge	Absolute	
1A	-25 to 25 inH <sub>2</sub> O (-62.16 to 62.16 mbar)	-25 to 25 inH <sub>2</sub> O (-62.16 to 62.16 mbar)	0 to 30 psia (0 to 2.07 bar)	★
2A	-250 to 250 inH <sub>2</sub> O (-621.60 to 621.60 mbar)	-250 to 250 inH <sub>2</sub> O (-621.60 to 621.60 mbar)	0 to 150 psia (0 to 10.34 bar)	★
3A	-1000 to 1000 inH <sub>2</sub> O (-2.49 to 2.49 bar)	-393 to 1000 inH <sub>2</sub> O (-0.97 to 2.49 bar)	0 to 800 psia (0 to 55.16 bar)	★
4A	-300 to 300 psi (-20.68 to 20.68 bar)	-14.2 to 300 psig (-0.97 to 20.68 bar)	0 to 4000 psia (0 to 275.79 bar)	★
5A	-2000 to 2000 psi (-137.89 to 137.89 bar)	-14.2 to 2000 psig (-0.97 to 137.89 bar)	N/A	★

Code	Description		
0A <sup>(1)</sup>	-3 to 3 inH <sub>2</sub> O (-7.46 to 7.46 mbar)	N/A	0 to 5 psia (0 to 0.34 bar)

(1) 3051S\_CDO is only available with SST traditional flange, 316L SST diaphragm material, glass-filled PTFE O-ring (standard), and Bolting option L4.

### Isolating diaphragm

Code	Description	
2 <sup>(1)</sup>	316L SST	★
3 <sup>(1)</sup>	Alloy C-276	★
4 <sup>(1)</sup>	Alloy 400	
5 <sup>(2)</sup>	Tantalum	
6 <sup>(1)</sup>	Gold-plated Alloy 400 (includes graphite-filled PTFE O-ring)	
7 <sup>(1)</sup>	Gold-plated 316L SST	

(1) Materials of construction comply with metallurgical requirements highlighted within NACE MR0175/ISO 15156 for sour oil field production environments. Environmental limits apply to certain materials. Consult latest standard for details. Selected materials also conform to NACE MR0103 for sour refining environments. Order with Q15 or Q25 to receive a NACE certificate.

(2) Tantalum diaphragm material is only available for ranges 2A-5A, differential and gauge.

### Process connection

Code	Description	Size	Materials of construction			
			Flange material	Drain vent	Bolting	
000	None (no process flange)	N/A	N/A	N/A	N/A	★
A11 <sup>(1)</sup>	Assemble to Rosemount 305 integral manifold	N/A	N/A	N/A	N/A	★
A12 <sup>(1)</sup>	Assemble to Rosemount 304 or AMF manifold and SST traditional flange	N/A	N/A	N/A	N/A	★
A15	Assemble to Rosemount 304 or AMF manifold to SST traditional flange with Alloy C-276 drain vents	N/A	N/A	N/A	N/A	★
A16 <sup>(1)</sup>	Assemble to 304 or AMF manifold to DIN SST traditional flange	N/A	N/A	N/A	N/A	★
A22	Assemble to Rosemount 304 or AMF manifold to SST coplanar flange	N/A	N/A	N/A	N/A	★
B11 <sup>(1)(2)(3)</sup>	Assemble to one Rosemount 1199 seal	N/A	SST	N/A	N/A	★
B12 <sup>(1)(2)(3)</sup>	Assemble to two Rosemount 1199 seals	N/A	SST	N/A	N/A	★
C11 <sup>(1)</sup>	Assemble to Rosemount 405C or 405P primary element	N/A	N/A	N/A	N/A	★

Code	Description	Size	Materials of construction			
			Flange material	Drain vent	Bolting	
D11 <sup>(1)</sup>	Assemble to Rosemount 1195 integral orifice and Rosemount 305 integral manifold	N/A	N/A	N/A	N/A	★
EA2 <sup>(1)</sup>	Assemble to Rosemount 485 or 405A Annubar primary element with coplanar flange	N/A	SST	316 SST	N/A	★
EA3 <sup>(1)</sup>	Assemble to Rosemount 485 or 405A Annubar primary element with coplanar flange	N/A	Cast C-276	Alloy C-276	N/A	★
EA5 <sup>(1)</sup>	Assemble to Rosemount 485 or 405A Annubar primary element with coplanar flange	N/A	SST	Alloy C-276	N/A	★
E11	Coplanar flange	¼–18 NPT	CS	316 SST	N/A	★
E12	Coplanar flange	¼–18 NPT	SST	316 SST	N/A	★
E13 <sup>(4)</sup>	Coplanar flange	¼–18 NPT	Cast C-276	Alloy C-276	N/A	★
E14	Coplanar flange	¼–18 NPT	Cast Alloy 400	Alloy 400/K-500	N/A	★
E15 <sup>(4)</sup>	Coplanar flange	¼–18 NPT	SST	Alloy C-276	N/A	★
E16 <sup>(4)</sup>	Coplanar flange	¼–18 NPT	CS	Alloy C-276	N/A	★
E21	Coplanar flange	RC ¼	CS	316 SST	N/A	★
E22	Coplanar flange	RC ¼	SST	316 SST	N/A	★
E23 <sup>(4)</sup>	Coplanar flange	RC ¼	Cast C-276	Alloy C-276	N/A	★
E24	Coplanar flange	RC ¼	Cast Alloy 400	Alloy 400/K-500	N/A	★
E25 <sup>(4)</sup>	Coplanar flange	RC ¼	SST	Alloy C-276	N/A	★
E26 <sup>(4)</sup>	Coplanar flange	RC ¼	CS	Alloy C-276	N/A	★
F12	Traditional flange	¼–18 NPT	SST	316 SST	N/A	★
F13 <sup>(4)</sup>	Traditional flange	¼–18 NPT	Cast C-276	Alloy C-276	N/A	★
F14	Traditional flange	¼–18 NPT	Cast Alloy 400	Alloy 400/K-500	N/A	★
F15 <sup>(4)</sup>	Traditional flange	¼–18 NPT	SST	Alloy C-276	N/A	★
F22	Traditional flange	RC ¼	SST	316 SST	N/A	★
F23 <sup>(4)</sup>	Traditional flange	RC ¼	Cast C-276	Alloy C-276	N/A	★
F24	Traditional flange	RC ¼	Cast Alloy 400	Alloy 400/K-500	N/A	★
F25 <sup>(4)</sup>	Traditional flange	RC ¼	SST	Alloy C-276	N/A	★
F52	DIN-compliant traditional flange	¼–18 NPT	SST	316 SST	7/16-in. bolting	★
G11	Vertical mount level flange	2-in. ANSI Class 150	SST	316 SST	N/A	★
G12	Vertical mount level flange	2-in. ANSI Class 300	SST	316 SST	N/A	★
G21	Vertical mount level flange	3-in. ANSI Class 150	SST	316 SST	N/A	★

Code	Description	Size	Materials of construction			
			Flange material	Drain vent	Bolting	
G22	Vertical mount level flange	3-in. ANSI Class 300	SST	316 SST	N/A	★
G31	Vertical mount level flange	DIN- DN 50 PN 40	SST	316 SST	N/A	★
G41	Vertical mount level flange	DIN- DN 80 PN 40	SST	316 SST	N/A	★
F32	Bottom vent traditional flange	¼-18 NPT	SST	316 SST	N/A	
F42	Bottom vent traditional flange	RC ¼	SST	316 SST	N/A	
F62	DIN-compliant traditional flange	¼-18 NPT	SST	316 SST	M10 bolting	
F72	DIN-compliant traditional flange	¼-18 NPT	SST	316 SST	M12 bolting	

- (1) "Assemble to" items are specified separately and require a completed model number. Process connection option codes B12, C11, D11, EA2, EA3, and EA5 are only available on differential Measurement Type, code D.
- (2) Consult an Emerson representative for performance specifications.
- (3) Not available with Performance Class code 3.
- (4) Materials of Construction comply with metallurgical requirements highlighted within NACE MR0175/ISO 15156 for sour oil field production environments. Environmental limits apply to certain materials. Consult latest standard for details. Selected materials also conform to NACE MR0103 for sour refining environments. Order with Q15 or Q25 to receive a NACE certificate.

### Transmitter output

Code	Description	
A	4-20 mA with digital signal based on HART® protocol	★
F <sup>(1)</sup>	FOUNDATION™ Fieldbus protocol	★
X <sup>(2)</sup>	Wireless (requires wireless options and wireless Plantweb™ housing)	★

- (1) Requires Plantweb housing.
- (2) Only intrinsically safe approval codes apply.

### Housing style

Code	Description	Material	Conduit entry size	
00	None (SuperModule™ spare part, order output code A)	N/A	N/A	★
1A	Plantweb™ housing	Aluminum	½-14 NPT	★
1B	Plantweb housing	Aluminum	M20 x 1.5	★
1J	Plantweb housing	SST	½-14 NPT	★
1K	Plantweb housing	SST	M20 x 1.5	★
5A <sup>(1)</sup>	Wireless Plantweb housing	Aluminum	½-14 NPT	★
5J <sup>(1)</sup>	Wireless Plantweb housing	SST	½-14 NPT	★
2A	Junction box housing	Aluminum	½-14 NPT	★
2B	Junction box housing	Aluminum	M20 x 1.5	★
2J	Junction box housing	SST	½-14 NPT	★

Code	Description	Material	Conduit entry size	
2E	Junction box housing with output for remote display and interface	Aluminum	½–14 NPT	★
2F	Junction box housing with output for remote display and interface	Aluminum	M20 x 1.5	★
2M	Junction box housing with output for remote display and interface	SST	½–14 NPT	★
7J <sup>(2)</sup>	Quick connect (A size mini, 4-pin male termination)	SST	N/A	★
1C	Plantweb housing	Aluminum	G½	
1L	Plantweb housing	SST	G½	
2C	Junction box housing	Aluminum	G½	
2G	Junction box housing with output for remote display and interface	Aluminum	G½	

(1) Only available with output code X.

(2) Available with output code A only. Available approvals are FM Intrinsically Safe; Nonincendive (option code I5), CSA Intrinsically Safe (option code I6), ATEX Intrinsic Safety (option code I1), or IECEx Intrinsic Safety (option code I7). Contact an Emerson representative for additional information.

## Wireless options

### Update rate

Code	Description	
WA	User configurable update rate	★

### Operating frequency and protocol

Code	Description	
3	2.4 GHz DSSS, IEC 62591 (WirelessHART)	★

### Omni-directional wireless antenna

Code	Description	
WK	External antenna	★
WM	Extended range, external antenna	★
WJ	Remote antenna	★
WN	High-gain, remote antenna	

### SmartPower™

Long-Life Power Module must be shipped separately, order Power Module 701PBKKF.

Code	Description	
1	Adapter for black power module (I.S. Power Module sold separately)	★



## Additional options

### HART® Revision configuration (requires HART Protocol output code A)

Option HR7 configures the HART output to HART Revision 7. This option requires the selection of the Advanced Diagnostics (DA2) option. The device with this option can be field configured to HART Revision 5 or 7 if desired.

Code	Description	
HR7	Configured for HART Revision 7	★

### Extended product warranty

Code	Description	
WR3	3-year limited warranty	★
WR5	5-year limited warranty	★

### Plantweb control functionality

Requires FOUNDATION™ Fieldbus output code F.

Code	Description	
A01	FOUNDATION Fieldbus advanced control function block suite	★

### Diagnostics suite

Code	Description	
D01	FOUNDATION™ Fieldbus diagnostics suite (Process Intelligence, Plugged Impulse Line diagnostic)	★
DA2 <sup>(1)</sup>	Advanced HART® diagnostics suite (Process Intelligence, Loop Integrity, Plugged Impulse Line diagnostic, Process Alerts, Service Alerts, Variable Log, Event Log)	★

(1) Requires Plantweb housing and output code A. Includes Hardware Adjustments as standard.

### Mounting bracket

For process connection option code A11, the mounting bracket must be ordered as part of the manifold model number.

Code	Description	
B4	Coplanar flange bracket, all SST, 2-in. pipe and panel	★
B1	Traditional flange bracket, CS, 2-in. pipe	★
B2	Traditional flange bracket, CS, panel	★
B3	Traditional flange flat bracket, CS, 2-in. pipe	★
B7	Traditional flange bracket, B1 with SST bolts	★
B8	Traditional flange bracket, B2 with SST bolts	★
B9	Traditional flange bracket, B3 with SST bolts	★
BA	Traditional flange bracket, B1, all SST	★
BC	Traditional flange bracket, B3, all SST	★

Code	Description	
BE	316SST B4-style bracket with 316SST bolting	★

## Software configuration

Code	Description	
C1 <sup>(1)</sup>	Custom software configuration (requires Configuration Data Sheet)	★
C2	Custom flow configuration (requires H01 and Configuration Data Sheet)	★

(1) Not available with output code F.

## Gauge pressure calibration

Code	Description	
C3	Gauge pressure calibration on Rosemount 3051S_CA4 only	★

## Alarm limit

This is not available with output code F and X.

Code	Description	
C4	NAMUR alarm and saturation levels, high alarm	★
C5	NAMUR alarm and saturation levels, low alarm	★
C6	Custom alarm and saturation signal levels, high alarm (requires C1 and Configuration Data Sheet)	★
C7	Custom alarm and saturation signal levels, low alarm (requires C1 and Configuration Data Sheet)	★
C8	Low alarm (standard Rosemount alarm and saturation levels)	★

## Hardware adjustments

This is not available with output code F, X, and housing style codes 00, 2E, 2F, 2G, 2M, 5A, 5J, or 7J.

Code	Description	
D1	Hardware adjustments (zero, span, alarm, security)	★

## Flange adapter

This is not available with process connection option code A11.

Code	Description	
D2	½-14 NPT flange adapter	★
D9	RC½ SST flange adapter	

### Custody transfer

Requires Plantweb™ housing and Hardware Adjustments option code D1. Limited availability depending on transmitter type and range. Contact an Emerson representative for additional information.

Code	Description	
D3	Measurement Canada accuracy approval	★

### Ground screw

This assembly is included with options EP, KP, E1, N1, K1, ND, E4, E7, N7, K7, E2, E3, KA, KC, KD, IA, IB, IE, IF, IG, KG, T1, K2, N3, EM, and KM.

Code	Description	
D4	External ground screw assembly	★

### Drain/vent valve

This is not available with process connection option code A11.

Code	Description	
D5	Delete transmitter drain/vent valves (install plugs)	★
D7	SST coplanar flange without drain/vent ports	

### Conduit plug

Transmitter is shipped with 316 SST conduit plug (uninstalled) in place of standard aluminum conduit plug.

Code	Description	
DO	316 SST conduit plug	★

### Product certifications

Valid when SuperModule™ Platform and housing have equivalent approvals.

Code	Description	
E1	ATEX Flameproof	★
I1	ATEX Intrinsic Safety	★
IA	ATEX FISCO Intrinsic Safety (FOUNDATION™ Fieldbus protocol only)	★
N1	ATEX Type n	★
K1	ATEX Flameproof, Intrinsic Safety, Type n, Dust	★
ND	ATEX Dust	★
E4	TIIS Flameproof	★
I4 <sup>(1)</sup>	TIIS Intrinsic Safety	★
E5	FM Explosion-proof, Dust Ignition-proof	★
I5	FM Intrinsically Safe; Nonincendive	★
IE	FM FISCO Intrinsically Safe (FOUNDATION Fieldbus protocol only)	★
K5	FM Explosion-proof, Dust Ignition-proof, Intrinsically Safe, Division 2	★

Code	Description	
E6 <sup>(2)</sup>	CSA Explosion-proof, Dust Ignition-proof, Division 2	★
I6	CSA Intrinsically Safe	★
IF	CSA FISCO Intrinsically Safe (FOUNDATION Fieldbus protocol only)	★
K6 <sup>(2)</sup>	CSA Explosion-proof, Dust Ignition-proof, Intrinsically Safe, Division 2	★
E7	IECEX Flameproof, Dust	★
I7	IECEX Intrinsic Safety	★
IG	IECEX FISCO Intrinsic Safety (FOUNDATION Fieldbus protocol only)	★
N7	IECEX Type n	★
K7	IECEX Flameproof, Dust, Intrinsic Safety, Type n	★
E2	INMETRO Flameproof	★
I2	INMETRO Intrinsic Safety	★
IB	INMETRO FISCO Intrinsic Safety	★
K2	INMETRO Flameproof, Intrinsic Safety	★
E3	China Flameproof	★
I3	China Intrinsic Safety	★
N3	China Type n	★
EP	Korea Flameproof	★
IP	Korea Intrinsic Safety	★
KP	Korea Flameproof, Intrinsic Safety	★
EM	Technical Regulations Customs Union (EAC) Flameproof	★
IM	Technical Regulations Customs Union (EAC) Intrinsic Safety	★
IN	Technical Regulations Customs Union (EAC) FISCO Intrinsic Safety	★
KM	Technical Regulations Customs Union (EAC) Flameproof, Intrinsic Safety	★
KA <sup>(2)</sup>	ATEX and CSA Flameproof, Intrinsically Safe, Division 2	★
KB <sup>(2)</sup>	FM and CSA Explosion-proof, Dust Ignition-proof, Intrinsically Safe, Division 2	★
KC	FM and ATEX Explosion-proof, Intrinsically Safe, Division 2	★
KD <sup>(2)</sup>	FM, CSA, and ATEX Explosion-proof, Intrinsically Safe	★
KG	FM, CSA, ATEX and IECEX FISCO Intrinsic Safety	★
KQ	USA, Canada, ATEX Intrinsic Safety Combination	★
KS	USA, Canada, IECEX, ATEX Explosion Proof, Intrinsically Safe, Dust, Non-Incendive, Type-N, Division 2	★

(1) Only available with output code X.

(2) Not available with M20 or G½ conduit entry size.

### Shipboard approvals

Code	Description	
SBS	American Bureau of Shipping	★

Code	Description	
SBV	Bureau Veritas (BV) Type Approval	★
SDN	Det Norske Veritas (DNV) Type Approval	★
SLL	Lloyds Register (LR) Type Approval	★

### Stainless steel tagging

Code	Description	
Y2	316 SST nameplate, top tag, wire-on tag(s), and fasteners	★

### Sensor fill fluid

Only available on differential and gauge measurement types. Silicone fill fluid is standard.

Code	Description	
L1	Inert sensor fill fluid	★

### O-ring

Code	Description	
L2	Graphite-filled PTFE O-ring	★

### Bolting material

This is not available with process connection option code A11.

Code	Description	
L4	Austenitic 316 SST bolts	★
L5	ASTM A 193, Grade B7M bolts	★
L6	Alloy K-500 bolts	★
L7 <sup>(1)</sup>	ASTM A453, Class D, Grade 660 bolts	★
L8	ASTM A193, Class 2, Grade B8M bolts	★

(1) Bolts are not considered process wetted. In instances where NACE MR0175/ISO 15156 and NACE MR0103 conformance is required for bolting, L7 is the recommended bolting option.

### Display type

This is not available with housing code 7].

Code	Description	
M5	Plantweb™ LCD display	★
M7 <sup>(1)(2)(3)</sup>	Remote mount LCD display and interface, Plantweb housing, no cable, SST bracket	★
M8 <sup>(1)(2)</sup>	Remote mount LCD display and interface, Plantweb housing, 50 ft. (15 m) cable, SST bracket	★
M9 <sup>(1)(2)</sup>	Remote mount LCD display and interface, Plantweb housing, 100 ft. (31 m) cable, SST bracket	★

(1) Not available with output code X.

- (2) Not available with output code F, option code DA2, or option code QT.  
 (3) See the Rosemount 3051S [Reference Manual](#) for cable requirements. Contact an Emerson representative for additional information.

## Pressure testing

P1 is not available with 3051S\_CA0.

Code	Description
P1	Hydrostatic testing with certificate

## Special cleaning

This is not available with process connection option code A11.

Code	Description
P2	Cleaning for special services
P3	Cleaning for special services with testing for <1PPM chlorine/fluorine

## Maximum static line pressure

Code	Description
P9 <sup>(1)</sup>	4500 psig (310 bar) static pressure limit (Rosemount 3051S_CD only) ★
P0 <sup>(2)</sup>	6092 psig (420 bar) static pressure limit (Rosemount 3051S_CD only) ★

- (1) When assembled to remote diaphragm seal system using B11 or B12 process connections, the maximum working pressure of the system may be limited by the rating of the Rosemount 1199 Seal System selected.  
 (2) Requires 316L SST, Alloy C-276, or Gold-plated 316L SST diaphragm material, assemble to Rosemount 305 integral manifold or DIN-compliant traditional flange process connection, and bolting option L8. Limited to Pressure Range (Differential), ranges 2A – 5A.

## Calibration certification

Code	Description
Q4	Calibration certificate ★
QP	Calibration certificate and tamper evident seal ★

## Material traceability certification

Code	Description
Q8	Material traceability certification per EN 10204 3.1 ★

## Positive material identification (PMI)

Code	Description
Q76	PMI verification and certificate ★

### Quality certification for safety

This is not available with output code F or X. Not available with housing code 7J.

Code	Description	
QT	Safety-certified to IEC 61508 with certificate of FMEDA data	★

### Transient protection

The T1 option is not needed with FISCO Product Certifications; transient protection is included in the FISCO product certification codes IA, IB, IE, IF, IG, and KG. This is not available with Housing code 00, 5A, 5J, or 7J.

Code	Description	
T1	Transient terminal block	★

### Drinking water approval

Requires 316L SST diaphragm material, glass-filled PTFE O-ring (standard), and Process Connection code E12 or F12.

Code	Description	
DW	NSF drinking water approval	★

### Surface finish certification

Code	Description	
Q16	Surface finish certification for sanitary remote seals	★

### Toolkit total system performance reports

Code	Description	
QZ	Remote seal system performance calculation report	★

### Conduit electrical connector

This is not available with Housing code 00, 5A, 5J, or 7J. Available with Intrinsically Safe approvals only. For FM Intrinsically Safe; Nonincendive (option code I5) or FM FISCO Intrinsically Safe (option code IE), install in accordance with Rosemount drawing 03151-1009. Suitable for use with all IS approvals (I1, I2, I3, I5, I6, I7, IA, IB, IE, IF, IG, IP, IM, KG).

Code	Description	
GE	M12, 4-pin, male connector (eurofast®)	★
GM	A size mini, 4-pin, male connector (minifast®)	★

### NACE® Certificate

NACE compliant wetted materials are identified by Materials of Construction comply with metallurgical requirements highlighted within NACE MR0175/ISO 15156 for sour oil field production environments. Environmental limits apply to certain materials. Consult latest standard for details. Selected materials also conform to NACE MR0103 for sour refining environments. Order with Q15 or Q25 to receive a NACE certificate. .

Code	Description	
Q15	Certificate of compliance to NACE MR0175/ISO 15156 for wetted materials	★

Code	Description	
Q25	Certificate of compliance to NACE MR0103 for wetted materials	★

### Cold temperature

This is only available on pressure ranges 1-5, with silicone sensor fill fluid and SST or C-276 isolating diaphragms.

Code	Description	
BR5	-58 °F (-50 °C) cold temperature operation	★
BR6	-76 °F (-60 °C) cold temperature operation	★

### Thread sealants

Code	Description	
Z1	High temperature liquid thread sealant (-65 to 400 °F temperature rating)	★
Z2	Liquid thread sealant (-63 to 302 °F temperature rating)	★
Z3	Anaerobic PTFE paste	★



# Rosemount 3051S In-line Pressure Transmitter



Rosemount 3051S In-line Pressure Transmitters are the industry leader for Gauge and Absolute pressure measurement. The in-line, compact design allows the transmitter to be connected directly to a process for quick, easy and cost effective installation. Capabilities include:

- Ultra and Classic Performance
- 4–20 mA HART®, WirelessHART™, FOUNDATION™ Fieldbus protocols
- Safety certification (Option code QT)
- Advanced diagnostics (Option code DA2)
- Remote display and Interface (Option code M7, M8, or M9)

CONFIGURE >

VIEW PRODUCT >

## Online product configurator

Many products are configurable online using our Product Configurator. Select the **Configure** button or visit our [website](#) to start. With this tool's built-in logic and continuous validation, you can configure your products more quickly and accurately.

## Specifications and options

See the Specifications and options section for more details on each configuration. Specification and selection of product materials, options, or components must be made by the purchaser of the equipment. See the Material selection section for more information.

## Model codes

Model codes contain the details related to each product. Exact model codes will vary; an example of a typical model code is shown in [Figure 2](#).

**Figure 2: Model Code Example**

**3051C D 2 X 2 2 M5 B4**

1            2

1. Required model components (choices available on most)
2. Additional options (variety of features and functions that may be added to products)

## Optimizing lead time

The starred offerings (★) represent the most common options and should be selected for best delivery. The non-starred offerings are subject to additional delivery lead time.

## Required model components

### Model

Code	Description	
3051S	Scalable pressure transmitter	★

### Performance class

Code	Description	
1	Ultra: 0.025% span accuracy, 200:1 rangedown, 15-year stability, 15-year limited warranty	★
2	Classic: 0.035% span accuracy, 150:1 rangedown, 15-year stability	★

### Connection type

Code	Description	
T	In-line	★

### Measurement type

Code	Description	
G	Gauge	★
A	Absolute	★

### Pressure range

Code	Description		
	Gauge	Absolute	
1A	-14.7 to 30 psi (-1.01 to 2.06 bar)	0 to 30 psia (2.06 bar)	★
2A	-14.7 to 150 psi (-1.01 to 10.34 bar)	0 to 150 psia (10.34 bar)	★
3A	-14.7 to 800 psi (-1.01 to 55.15 bar)	0 to 800 psia (55.15 bar)	★
4A	-14.7 to 4000 psi (-1.01 to 275.79 bar)	0 to 4000 psia (275.79 bar)	★
5A	14.7 to 10000 psi (-1.01 to 689.47 bar)	0 to 10000 psia (689.47 bar)	★

### Isolating diaphragm

Materials of Construction comply with metallurgical requirements highlighted within NACE® MR0175/ISO 15156 for sour oil field production environments. Environmental limits apply to certain materials. Consult latest standard for details. Selected materials also conform to NACE MR0103 for sour refining environments. Order with Q15 or Q25 to receive a NACE certificate. Isolator diaphragm selection will dictate materials of construction for wetted parts.

Code	Description	
2	316L SST	★

Code	Description	
3	Alloy C-276	★

## Process connection

Code	Description	
A11 <sup>(1)</sup>	Assemble to Rosemount 306 integral manifold	★
B11 <sup>(1)(2)</sup>	Assemble to one Rosemount 1199 seal	★
E11	½–14 NPT female	★
G11	G½ A DIN 16288 male (range 1–4 only)	★
H11	Coned and threaded, compatible with autoclave type F-250-C (range 5A only)	
F11	Non-threaded instrument flange (I-flange) (range 1–4 only)	

(1) "Assemble to" items are specified separately and require a completed model number.

(2) Consult an Emerson representative for performance specifications.

## Transmitter output

Code	Description	
A	4–20 mA with digital signal based on HART® protocol	★
F <sup>(1)</sup>	FOUNDATION™ Fieldbus protocol	★
X <sup>(2)</sup>	Wireless (requires wireless options and wireless Plantweb™ housing)	★

(1) Requires Plantweb housing.

(2) Only intrinsically safe approval codes apply.

## Housing style

Code	Description	Material	Conduit entry size	
00	None (SuperModule™ spare part, order output code A)	N/A	N/A	★
1A	Plantweb™ housing	Aluminum	½–14 NPT	★
1B	Plantweb housing	Aluminum	M20 x 1.5	★
1J	Plantweb housing	SST	½–14 NPT	★
1K	Plantweb housing	SST	M20 x 1.5	★
5A <sup>(1)</sup>	Wireless Plantweb housing	Aluminum	½–14 NPT	★
5J <sup>(1)</sup>	Wireless Plantweb housing	SST	½–14 NPT	★
2A	Junction box housing	Aluminum	½–14 NPT	★
2B	Junction box housing	Aluminum	M20 x 1.5	★
2J	Junction box housing	SST	½–14 NPT	★
2E	Junction box housing with output for remote display and interface	Aluminum	½–14 NPT	★
2F	Junction box housing with output for remote display and interface	Aluminum	M20 x 1.5	★
2M	Junction box housing with output for remote display and interface	SST	½–14 NPT	★

Code	Description	Material	Conduit entry size	
7J <sup>(2)</sup>	Quick connect (A size mini, 4-pin male termination)	SST	N/A	★
1C	Plantweb housing	Aluminum	G½	
1L	Plantweb housing	SST	G½	
2C	Junction box housing	Aluminum	G½	
2G	Junction box housing with output for remote display and interface	Aluminum	G½	

(1) Only available with output code X.

(2) Available with output code A only. Available approvals are FM Intrinsically Safe; Nonincendive (option code I5), CSA Intrinsically Safe (option code I6), ATEX Intrinsic Safety (option code I1), or IECEx Intrinsic Safety (option code I7). Contact an Emerson representative for additional information.

## Wireless options

### Update rate

Code	Description	
WA	User configurable update rate	★

### Operating frequency and protocol

Code	Description	
3	2.4 GHz DSSS, IEC 62591 ( <i>WirelessHART</i> )	★

### Omni-directional wireless antenna

Code	Description	
WK	External antenna	★
WM	Extended range, external antenna	★
WJ	Remote antenna	★
WN	High-gain, remote antenna	

### SmartPower

Long-Life Power Module must be shipped separately, order Power Module 701PBKKF.

Code	Description	
1	Adapter for Black Power Module (I.S. Power Module sold separately)	★

## Additional options

### HART® Revision configuration (requires HART Protocol output code A)

Option HR7 configures the HART output to HART Revision 7. This option requires the selection of the Advanced Diagnostics (DA2) option. The device with this option can be field configured to HART Revision 5 or 7 if desired.

Code	Description	
HR7	Configured for HART Revision 7	★

### Extended product warranty

Code	Description	
WR3	3-year limited warranty	★
WR5	5-year limited warranty	★

### Plantweb control functionality

Requires FOUNDATION™ Fieldbus output code F.

Code	Description	
A01	FOUNDATION Fieldbus advanced control function block suite	★

### Diagnostics suite

Code	Description	
D01	FOUNDATION™ Fieldbus diagnostics suite (Process Intelligence, Plugged Impulse Line diagnostic)	★
DA2 <sup>(1)</sup>	Advanced HART® diagnostics suite (Process Intelligence, Loop Integrity, Plugged Impulse Line diagnostic, Process Alerts, Service Alerts, Variable Log, Event Log)	★

(1) Requires Plantweb housing and output code A. Includes Hardware Adjustments as standard.

### Mounting bracket

Code	Description	
B4	Bracket, all SST, 2-in. pipe and panel	★
BE	316SST B4-style bracket with 316SST bolting	★

### Software configuration

This is not available with output code F.

Code	Description	
C1	Custom software configuration (requires Configuration Data Sheet)	★

## Alarm limit

This is not available with output code F and X.

Code	Description	
C4	NAMUR alarm and saturation levels, high alarm	★
C5	NAMUR alarm and saturation levels, low alarm	★
C6	Custom alarm and saturation signal levels, high alarm (requires C1 and Configuration Data Sheet)	★
C7	Custom alarm and saturation signal levels, low alarm (requires C1 and Configuration Data Sheet)	★
C8	Low alarm (standard Rosemount alarm and saturation levels)	★

## Hardware adjustments

This is not available with output code F, X, and housing style codes 00, 2E, 2F, 2G, 2M, 5A, 5J, or 7J.

Code	Description	
D1	Hardware adjustments (zero, span, alarm, security)	★

## Custody transfer

Requires Plantweb™ housing and Hardware Adjustments option code D1. Limited availability depending on transmitter type and range. Contact an Emerson representative for additional information.

Code	Description	
D3	Measurement Canada accuracy approval	★

## Ground screw

This assembly is included with options EP, KP, E1, N1, K1, ND, E4, E7, N7, K7, E2, E3, KA, KC, KD, IA, IB, IE, IF, IG, KG, T1, K2, N3, EM, and KM.

Code	Description	
D4	External ground screw assembly	★

## Conduit plug

Transmitter is shipped with 316 SST conduit plug (uninstalled) in place of standard aluminum conduit plug.

Code	Description	
DO	316 SST conduit plug	★

## Product certifications

Valid when SuperModule™ Platform and housing have equivalent approvals.

Code	Description	
E1	ATEX Flameproof	★
I1	ATEX Intrinsic Safety	★
IA	ATEX FISCO Intrinsic Safety (FOUNDATION™ Fieldbus protocol only)	★
N1	ATEX Type n	★

Code	Description	
K1	ATEX Flameproof, Intrinsic Safety, Type n, Dust	★
ND	ATEX Dust	★
E4	TIIS Flameproof	★
I4 <sup>(1)</sup>	TIIS Intrinsic Safety	★
E5	FM Explosion-proof, Dust Ignition-proof	★
I5	FM Intrinsically Safe; Nonincendive	★
IE	FM FISCO Intrinsically Safe (FOUNDATION Fieldbus protocol only)	★
K5	FM Explosion-proof, Dust Ignition-proof, Intrinsically Safe, Division 2	★
E6 <sup>(2)</sup>	CSA Explosion-proof, Dust Ignition-proof, Division 2	★
I6	CSA Intrinsically Safe	★
IF	CSA FISCO Intrinsically Safe (FOUNDATION Fieldbus protocol only)	★
K6 <sup>(2)</sup>	CSA Explosion-proof, Dust Ignition-proof, Intrinsically Safe, Division 2	★
E7	IECEx Flameproof, Dust	★
I7	IECEx Intrinsic Safety	★
IG	IECEx FISCO Intrinsic Safety (FOUNDATION Fieldbus protocol only)	★
N7	IECEx Type n	★
K7	IECEx Flameproof, Dust, Intrinsic Safety, Type n	★
E2	INMETRO Flameproof	★
I2	INMETRO Intrinsic Safety	★
IB	INMETRO FISCO Intrinsic Safety	★
K2	INMETRO Flameproof, Intrinsic Safety	★
E3	China Flameproof	★
I3	China Intrinsic Safety	★
N3	China Type n	★
EP	Korea Flameproof	★
IP	Korea Intrinsic Safety	★
KP	Korea Flameproof, Intrinsic Safety	★
EM	Technical Regulations Customs Union (EAC) Flameproof	★
IM	Technical Regulations Customs Union (EAC) Intrinsic Safety	★
IN	Technical Regulations Customs Union (EAC) FISCO Intrinsic Safety	★
KM	Technical Regulations Customs Union (EAC) Flameproof, Intrinsic Safety	★
KA <sup>(2)</sup>	ATEX and CSA Flameproof, Intrinsically Safe, Division 2	★
KB <sup>(2)</sup>	FM and CSA Explosion-proof, Dust Ignition-proof, Intrinsically Safe, Division 2	★
KC	FM and ATEX Explosion-proof, Intrinsically Safe, Division 2	★
KD <sup>(2)</sup>	FM, CSA, and ATEX Explosion-proof, Intrinsically Safe	★
KG	FM, CSA, ATEX and IECEx FISCO Intrinsic Safety	★

Code	Description	
KQ	USA, Canada, ATEX Intrinsic Safety Combination	★
KS	USA, Canada, IECEx, ATEX Explosion Proof, Intrinsically Safe, Dust, Non-Incendive, Type-N, Division 2	★

(1) Only available with output code X.

(2) Not available with M20 or G½ conduit entry size.

## Shipboard approvals

Code	Description	
SBS	American Bureau of Shipping	★
SBV	Bureau Veritas (BV) Type Approval	★
SDN	Det Norske Veritas (DNV) Type Approval	★
SLL	Lloyds Register (LR) Type Approval	★

## Stainless steel tagging

Code	Description	
Y2	316 SST nameplate, top tag, wire-on tag(s), and fasteners	★

## Sensor fill fluid

Only available on differential and gauge measurement types. Silicone fill fluid is standard.

Code	Description	
L1	Inert sensor fill fluid	★

## Display type

This is not available with housing code 7J.

Code	Description	
M5	Plantweb™ LCD display	★
M7 <sup>(1)(2)(3)</sup>	Remote mount LCD display and interface, Plantweb housing, no cable, SST bracket	★
M8 <sup>(1)(2)</sup>	Remote mount LCD display and interface, Plantweb housing, 50 ft. (15 m) cable, SST bracket	★
M9 <sup>(1)(2)</sup>	Remote mount LCD display and interface, Plantweb housing, 100 ft. (31 m) cable, SST bracket	★

(1) Not available with output code X.

(2) Not available with output code F, option code DA2, or option code QT.

(3) See the Rosemount 3051S [Reference Manual](#) for cable requirements. Contact an Emerson representative for additional information.

## Pressure testing

P1 is not available with 3051S\_CA0.

Code	Description	
P1	Hydrostatic testing with certificate	



## Special cleaning

This is not available with process connection option code A11.

Code	Description
P2	Cleaning for special services
P3	Cleaning for special services with testing for <1PPM chlorine/fluorine

## Calibration certification

Code	Description
Q4	Calibration certificate
QP	Calibration certificate and tamper evident seal

## Material traceability certification

Code	Description
Q8	Material traceability certification per EN 10204 3.1

## Positive material identification (PMI)

Code	Description
Q76	PMI verification and certificate

## Quality certification for safety

Not available with output code F or X. Not available with housing code 7].

Code	Description
QT	Safety certified to IEC 61508 with certificate of FMEDA

## Transient protection

The T1 option is not needed with FISCO Product Certifications; transient protection is included in the FISCO product certification codes IA, IB, IE, IF, IG, and KG. Not available with Housing code 00, 5A, 5J, or 7J.

Code	Description
T1	Transient terminal block

## Drinking water approval

Requires 316L SST diaphragm material, glass-filled PTFE O-ring (standard), and Process Connection code E12 or F12.

Code	Description
DW	NSF drinking water approval

### Surface finish certification

Code	Description	
Q16	Surface finish certification for sanitary remote seals	★

### Toolkit total system performance reports

Code	Description	
QZ	Remote seal system performance calculation report	★

### Conduit electrical connector

This is not available with housing code 00, 5A, 5J, or 7J. Available with Intrinsically Safe approvals only. For FM Intrinsically Safe; Nonincendive (option code I5) or FM FISCO Intrinsically Safe (option code IE), install in accordance with Rosemount drawing 03151-1009. Suitable for use with all IS approvals (I1, I2, I3, I5, I6, I7, IA, IB, IE, IF, IG, IP, IM, KG).

Code	Description	
GE	M12, 4-pin, male connector (eurofast)	★
GM	A size mini, 4-pin, male connector (minifast)	★

### NACE® certificate

NACE compliant wetted materials are identified by Materials of Construction comply with metallurgical requirements highlighted within NACE MR0175/ISO 15156 for sour oil field production environments. Environmental limits apply to certain materials. Consult latest standard for details. Selected materials also conform to NACE MR0103 for sour refining environments. Order with Q15 or Q25 to receive a NACE certificate.

Code	Description	
Q15	Certificate of compliance to NACE MR0175/ISO 15156 for wetted materials	★
Q25	Certificate of compliance to NACE MR0103 for wetted materials	★

### Cold temperature

This is only available on pressure ranges 1-5, with silicone sensor fill fluid and SST or C-276 isolating diaphragms.

Code	Description	
BR5	-58 °F (-50 °C) cold temperature operation	★
BR6	-76 °F (-60 °C) cold temperature operation	★

# Rosemount 3051S MultiVariable™ Transmitter



The Rosemount 3051S MultiVariable Transmitter delivers unprecedented performance and capabilities by providing superior flow calculations including fully compensated mass or volume, energy, and totalized flow. Specify the level of compensation that best matches the application:

- Gas, natural gas, and steam measurement: Utilize full compensation (differential pressure, line pressure, and temperature measurement)
- Saturated steam: Utilize differential and line pressure, or differential pressure and temperature measurement
- Liquids: Utilize differential pressure and temperature measurement
- Liquids at stable temperatures: Utilize differential pressure measurement
- 4–20 mA HART®, WirelessHART®, FOUNDATION™ Fieldbus protocols

[CONFIGURE >](#)

[VIEW PRODUCT >](#)

## Online product configurator

Many products are configurable online using our Product Configurator. Select the **Configure** button or visit our [website](#) to start. With this tool's built-in logic and continuous validation, you can configure your products more quickly and accurately.

## Specifications and options

See the Specifications and options section for more details on each configuration. Specification and selection of product materials, options, or components must be made by the purchaser of the equipment. See the Material selection section for more information.

## Model codes

Model codes contain the details related to each product. Exact model codes will vary; an example of a typical model code is shown in [Figure 3](#).

**Figure 3: Model Code Example**

**3051C D 2 X 2 2 M5 B4**

1                      2

1. Required model components (choices available on most)
2. Additional options (variety of features and functions that may be added to products)

## Optimizing lead time

The starred offerings (★) represent the most common options and should be selected for best delivery. The non-starred offerings are subject to additional delivery lead time.

## Required model components

### Model

Code	Description
3051SMV	Scalable multivariable transmitter

### Performance class

Code	Description	
<b>Measurement types 1 and 2</b>		
3 <sup>(1)</sup>	Ultra for Flow: 0.04% reading DP accuracy, 200:1 rangedown, 15-year stability, 15-year limited warranty	★
5	Classic MV: 0.04% span DP accuracy, 100:1 rangedown, 15-year stability	★
<b>Measurement types 3 and 4</b>		
1	Ultra: 0.025% span DP accuracy, 200:1 rangedown, 15-year stability, 15-year limited warranty	★
2	Classic: 0.035% span DP accuracy, 150:1 rangedown, 15-year stability	★
3 <sup>(1)</sup>	Ultra for Flow: 0.04% reading DP accuracy, 200:1 rangedown, 15-year stability, 15-year limited warranty	★

(1) For measurement types 1 and 2, only available with DP range codes 2, 3, and 4, 316L SST and Alloy C-276 isolating diaphragm and silicone fill fluid. For measurements types 3 and 4, only available with DP range codes 2 and 3, 316L SST and Alloy C-276 isolating diaphragm and silicone fill fluid.

### Multivariable type

Code	Description	
M	Measurement with fully compensated mass and energy <sup>(1)</sup> flow calculations	★
P	Measurement of process variables only (no flow calculations)	★

(1) Only available with transmitter output code A.

### Measurement type

Code	Description	
1	Differential pressure, static pressure, and temperature	★
2	Differential pressure and static pressure	★
3	Differential pressure and temperature	★
4	Differential pressure	★

### Differential pressure range

If ordering measurement type code M, DP Range 4 and 5 are not available.

Code	Description	
0 <sup>(1)</sup>	-3 to 3 inH <sub>2</sub> O (-7.46 to 7.46 mbar)	★
1	-25 to 25 inH <sub>2</sub> O (-62.16 to 62.16 mbar)	★

Code	Description	
2	-250 to 250 inH <sub>2</sub> O (-621.60 to 621.60 mbar)	★
3	-1000 to 1000 inH <sub>2</sub> O (-2.48 to 2.48 bar)	★
4 <sup>(2)</sup>	-150 to 150 psi (-10.34 to 10.34 bar) for measurement types 1 and 2; -300 to 300 psi (-20.68 to 20.68 bar) for measurement types 3 and 4	★
5 <sup>(2)</sup>	-2000 to 2000 psi (-137.89 to 137.89 bar)	★

- (1) DP Range 0 is only available with measurement type 3 or 4 and traditional flange, 316L SST diaphragm material, and Bolting option L4.
- (2) DP Range 4 and 5 is only available with SP range N or 4 and Alloy C-276 diaphragm material.

### Static pressure type

Code	Description	
N <sup>(1)</sup>	None	★
A	Absolute	★
G	Gauge	★

- (1) Required for measurement type codes 3 and 4.

### Static pressure range

Code	Description	Absolute	Gauge	
N <sup>(1)</sup>	None	N/A	N/A	★
3	Range 3	0.5 to 800 psia (0.03 to 55.15 bar) -	-14.2 to 800 psig (-0.98 to 55.15 bar)	★
4 <sup>(2)</sup>	Range 4	0.5 to 3626 psia (0.03 to 250.00 bar)	-14.2 to 3626 psig (-0.98 to 250.00 bar)	★
5 <sup>(3)(4)(5)</sup>	Range 5	N/A	-14.2 to 6092 PSI (420 bar)	★

- (1) Required for measurement type codes 3 and 4.
- (2) For measurement type codes 1 and 2 with DP range 1, absolute limits are 0.5 to 2000 psi (0.03 to 137.9 bar) and gauge limits are -14.2 to 2000 psig (-0.98 to 137.9 bar).
- (3) Static pressure range 5 is only available with DP ranges 2,3, or 4, bolting type L8 and static pressure type G, and requires isolating diaphragm 2 or 3 as well as process connection 000, A11, F52, or F72.
- (4) Static pressure range 5 is a sealed gauge sensor.
- (5) For temperature range -40 to -20 °F URL is 4500 PSI (310.26 bar), for temperature range -20 to 185 °F URL is 6092 PSI (420 bar).

### Temperature input

Code	Description	
N <sup>(1)</sup>	None	★
R <sup>(2)</sup>	RTD input (type Pt 100, -328 to 1562 °F [-200 to 850 °C])	★

- (1) Required for measurement type codes 2 and 4.
- (2) Required for measurement type codes 1 and 3. RTD Sensor must be ordered separately.

## Isolating diaphragm

Code	Description	
2 <sup>(1)</sup>	316L SST	★
3 <sup>(1)</sup>	Alloy C-276	★
5 <sup>(2)</sup>	Tantalum	
7 <sup>(1)</sup>	Gold-plated 316L SST	

(1) *Materials of Construction comply with metallurgical requirements highlighted within NACE MR0175/ISO 15156 for sour oil field production environments. Environmental limits apply to certain materials. Consult latest standard for details. Selected materials also conform to NACE MR0103 for sour refining environments. Order with Q15 or Q25 to receive a NACE certificate.*

(2) *Tantalum diaphragm material is only available for DP ranges 2-5.*

## Process connection

Code	Description	Size	Material type			
			Flange material	Drain vent	Bolting	
000	None (no process flange)	N/A	N/A	N/A	N/A	★
A11 <sup>(1)</sup>	Assemble to Rosemount 305/306 integral manifold	N/A	N/A	N/A	N/A	★
A12 <sup>(1)</sup>	Assemble to Rosemount 304 or AMF manifold with SST traditional flange	N/A	N/A	N/A	N/A	★
A15 <sup>(1)</sup>	Assemble to Rosemount 304 or AMF manifold to SST traditional flange with Alloy C-276 drain vents	N/A	N/A	N/A	N/A	★
A16 <sup>(1)</sup>	Assemble to Rosemount 304 or AMF manifold to DIN SST traditional flange	N/A	N/A	N/A	N/A	★
A22	Assemble to Rosemount 304 or AMF manifold to SST coplanar flange	N/A	N/A	N/A	N/A	★
B11 <sup>(1)(2)</sup>	Assemble to one Rosemount 1199 seal	N/A	N/A	N/A	N/A	★
B12 <sup>(1)(2)</sup>	Assemble to two Rosemount 1199 seals	N/A	N/A	N/A	N/A	★
C11 <sup>(1)</sup>	Assemble to Rosemount 405C or 405P primary element	N/A	N/A	N/A	N/A	★
D11 <sup>(1)</sup>	Assemble to Rosemount 1195 integral orifice and Rosemount 305 integral manifold	N/A	N/A	N/A	N/A	★
EA2 <sup>(1)</sup>	Assemble to Rosemount 485 or 405A Annubar primary element with coplanar flange	N/A	SST	316 SST	N/A	★
EA3 <sup>(1)</sup>	Assemble to Rosemount 485 or 405A Annubar primary element with coplanar flange	N/A	Cast C-276	Alloy C-276	N/A	★

Code	Description	Size	Material type			
			Flange material	Drain vent	Bolting	
EA5 <sup>(1)</sup>	Assemble to Rosemount 485 or 405A Annubar primary element with coplanar flange	N/A	SST	Alloy C-276	N/A	★
E11	Coplanar flange	¼–18 NPT	Carbon steel	316 SST	N/A	★
E12	Coplanar flange	¼–18 NPT	SST	316 SST	N/A	★
E13 <sup>(3)</sup>	Coplanar flange	¼–18 NPT	Cast C-276	Alloy C-276	N/A	★
E14	Coplanar flange	¼–18 NPT	Cast Alloy 400	Alloy 400/K-500	N/A	★
E15 <sup>(3)</sup>	Coplanar flange	¼–18 NPT	SST	Alloy C-276	N/A	★
E16 <sup>(3)</sup>	Coplanar flange	¼–18 NPT	Carbon steel	Alloy C-276	N/A	★
E21	Coplanar flange	RC ¼	Carbon steel	316 SST	N/A	★
E22	Coplanar flange	RC ¼	SST	316 SST	N/A	★
E23 <sup>(3)</sup>	Coplanar flange	RC ¼	Cast C-276	Alloy C-276	N/A	★
E24	Coplanar flange	RC ¼	Cast Alloy 400	Alloy 400/K-500	N/A	★
E25 <sup>(3)</sup>	Coplanar flange	RC ¼	SST	Alloy C-276	N/A	★
E26 <sup>(3)</sup>	Coplanar flange	RC ¼	Carbon steel	Alloy C-276	N/A	★
F12	Traditional flange	¼–18 NPT	SST	316 SST	N/A	★
F13 <sup>(3)</sup>	Traditional flange	¼–18 NPT	Cast C-276	Alloy C-276	N/A	★
F14	Traditional flange	¼–18 NPT	Cast Alloy 400	Alloy 400/K-500	N/A	★
F15 <sup>(3)</sup>	Traditional flange	¼–18 NPT	SST	Alloy C-276	N/A	★
F22	Traditional flange	RC ¼	SST	316 SST	N/A	★
F23 <sup>(3)</sup>	Traditional flange	RC ¼	Cast C-276	Alloy C-276	N/A	★
F24	Traditional flange	RC ¼	Cast Alloy 400	Alloy 400/K-500	N/A	★
F25 <sup>(3)</sup>	Traditional flange	RC ¼	SST	Alloy C-276	N/A	★
F52	DIN-compliant traditional flange	¼–18 NPT	SST	316 SST	7/16-in. bolting	★
G11	Vertical mount level flange	2-in. ANSI Class 150	SST	N/A	N/A	★
G12	Vertical mount level flange	2-in. ANSI Class 300	SST	N/A	N/A	★
G14 <sup>(3)</sup>	Vertical mount level flange	2-in. ANSI Class 150	Cast C-276	N/A	N/A	★
G15 <sup>(3)</sup>	Vertical mount level flange	2-in. ANSI Class 300	Cast C-276	N/A	N/A	★
G21	Vertical mount level flange	3-in. ANSI Class 150	SST	N/A	N/A	★
G22	Vertical mount level flange	3-in. ANSI Class 300	SST	N/A	N/A	★
G31	Vertical mount level flange	DIN- DN 50 PN 40	SST	N/A	N/A	★
F32	Bottom vent traditional flange	¼–18 NPT	SST	316 SST	N/A	
F42	Bottom vent traditional flange	RC ¼	SST	316 SST	N/A	
F62	DIN-compliant traditional flange	¼–18 NPT	SST	316 SST	M10 bolting	

Code	Description	Size	Material type		
			Flange material	Drain vent	Bolting
F72	DIN-compliant traditional flange	¼–18 NPT	SST	316 SST	M12 bolting
G41	Vertical mount level flange	DIN- DN 80 PN 40	SST	N/A	N/A

- (1) "Assemble to" items are specified separately and require a completed model number.  
 (2) Consult an Emerson representative for performance specifications.  
 (3) Materials of Construction comply with metallurgical requirements highlighted within NACE MR0175/ISO 15156 for sour oil field production environments Environmental limits apply to certain materials. Consult latest standard for details. Selected materials also conform to NACE MR0103 for sour refining environments. Order with Q15 or Q25 to receive a NACE certificate.

## Transmitter output

Code	Description	
A	4–20 mA with digital signal based on HART® protocol	★
X <sup>(1)</sup>	Wireless (requires wireless options and wireless Plantweb™ housing)	★
F <sup>(2)(3)</sup>	FOUNDATION™ Fieldbus	★

- (1) Only available with Measurement Type 2 and multivariable type P  
 (2) Transmitter output code F is not available with Performance Class 1 and 2 and Measurement Type 3 and 4  
 (3) If ordered with static pressure range 5, only available with multivariable type P.

## Housing style

Code	Description	Material	Conduit entry size	
1A	Plantweb™ housing	Aluminum	½–14 NPT	★
1B	Plantweb housing	Aluminum	M20 x 1.5	★
1J	Plantweb housing	SST	½–14 NPT	★
1K	Plantweb housing	SST	M20 x 1.5	★
5A <sup>(1)</sup>	Wireless Plantweb housing	Aluminum	½–14 NPT	★
5J <sup>(1)</sup>	Wireless Plantweb housing	SST	½–14 NPT	★
1C	Plantweb housing	Aluminum	G½	
1L	Plantweb housing	SST	G½	

- (1) Only available with output code X.

## Wireless options

### Update rate

Code	Description	
WA	User configurable update rate	★



## Operating frequency and protocol

Code	Description	
3	2.4 GHz DSSS, IEC 62591 ( <i>WirelessHART</i> )	★

## Omni-directional wireless antenna

Code	Description	
WK	External antenna	★
WM	Extended range, external antenna	★
WN	High-gain, remote antenna	★

## SmartPower

Long-Life Power Module must be shipped separately, order Power Module 701PBKKF.

Code	Description	
1	Adapter for Black Power Module (I.S. Power Module sold separately)	★

## Additional options

### Extended product warranty

Code	Description	
WR3	3-year limited warranty	★
WR5	5-year limited warranty	★

### RTD cable

RTD sensor must be ordered separately.

Code	Description	
C12	RTD input with 12 ft. (3.66 m) of shielded cable	★
C13	RTD input with 24 ft. (7.32 m) of shielded cable	★
C14	RTD input with 75 ft. (22.86 m) of shielded cable	★
C22	RTD input with 12 ft. (3.66 m) of armored shielded cable	★
C23	RTD input with 24 ft. (7.32 m) of armored shielded cable	★
C24	RTD input with 75 ft. (22.86 m) of armored shielded cable	★
C32	RTD input with 12 ft. (3.66 m) of ATEX/IECEx Flameproof cable	★
C33	RTD input with 24 ft. (7.32 m) of ATEX/IECEx Flameproof cable	★
C34	RTD input with 75 ft. (22.86 m) of ATEX/IECEx Flameproof cable	★

## Plantweb control functionality

Requires FOUNDATION™ Fieldbus output code F.

Code	Description	
A01	FOUNDATION Fieldbus advanced control function block suite	★

## Mounting bracket

For process connection option code A11, the mounting bracket must be ordered as part of the manifold model number.

Code	Description	
B4	Coplanar flange bracket, all SST, 2-in. pipe and panel	★
B1	Traditional flange bracket, CS, 2-in. pipe	★
B2	Traditional flange bracket, CS, panel	★
B3	Traditional flange flat bracket, CS, 2-in. pipe	★
B7	Traditional flange bracket, B1 with SST bolts	★
B8	Traditional flange bracket, B2 with SST bolts	★
B9	Traditional flange bracket, B3 with SST bolts	★
BA	Traditional flange bracket, B1, all SST	★
BC	Traditional flange bracket, B3, all SST	★
BE	316SST B4-style bracket with 316SST bolting	★

## Software configuration

Code	Description	
C1 <sup>(1)</sup>	Custom software configuration (Rosemount 3051SMV <a href="#">Configuration Data Sheet</a> must be completed for HART devices. Rosemount 3051SMV Wireless <a href="#">Configuration Data Sheet</a> must be completed for WirelessHART devices.)	★
C2 <sup>(2)</sup>	Custom flow configuration (A DP Flow <a href="#">Configuration Data Sheet</a> must be completed. Additionally, either a Rosemount 3051SMV Configuration Data Sheet for <a href="#">HART devices</a> or for <a href="#">Fieldbus devices</a> must be completed.)	★

(1) Not available with transmitter output code F

(2) Not available with transmitter output code X.

## Alarm limits

This is not available with transmitter output code F and X.

Code	Description	
C4	NAMUR alarm and saturation levels, high alarm	★
C5	NAMUR alarm and saturation levels, low alarm	★
C6	Custom alarm and saturation signal levels, high alarm	★
C7	Custom alarm and saturation signal levels, low alarm	★
C8	Low alarm (standard Rosemount alarm and saturation levels)	★

## Flange adapter

This is not available with process connection option code A11.

Code	Description	
D2	½-14 NPT flange adapter	★
D9	RC½ SST flange adapter	

## Ground screw

This assembly is included with options EP, KP, E1, N1, K1, ND, E4, E7, N7, K7, E2, E3, KA, KC, KD, IA, IB, IE, IF, IG, KG, T1, K2, N3, EM, and KM.

Code	Description	
D4	External ground screw assembly	★

## Drain/vent valve

This is not available with process connection option code A11.

Code	Description	
D5	Delete transmitter drain/vent valves (install plugs)	★
D7	SST coplanar flange without drain/vent ports	

## Conduit plug

Transmitter is shipped with 316 SST conduit plug (uninstalled) in place of standard aluminum conduit plug.

Code	Description	
DO	316 SST conduit plug	★

## Product certifications

Code	Description	
E1	ATEX Flameproof	★
I1	ATEX Intrinsic Safety	★
IA <sup>(1)</sup>	ATEX FISCO Intrinsic Safety	★
N1	ATEX Type n	★
ND	ATEX Dust	★
K1	ATEX Flameproof, Intrinsic Safety, Type n, Dust (combination of E1, I1, N1, and ND)	★
E4	TIIS Flameproof	★
E5	FM Explosion-proof, Dust Ignition-proof	★
I5	FM Intrinsically Safe; Nonincendive	★
IE <sup>(1)</sup>	FM FISCO Intrinsic Safety	★
K5	FM Explosion-proof, Dust Ignition-proof, Intrinsically Safe, Division 2 (combination of E5 and I5)	★
E6 <sup>(2)</sup>	CSA Explosion-proof, Dust Ignition-proof, Division 2	★

Code	Description	
I6	CSA Intrinsically Safe	★
IF <sup>(1)</sup>	CSA FISCO Intrinsic Safety	★
K6 <sup>(2)</sup>	CSA Explosion-proof, Dust Ignition-proof, Intrinsically Safe, Division 2 (combination of E6 and I6)	★
E7	IECEX Flameproof, Dust Ignition-proof	★
I7	IECEX Intrinsic Safety	★
IG <sup>(1)</sup>	IECEX FISCO Intrinsic Safety	★
N7	IECEX Type n	★
K7	IECEX Flameproof, Dust Ignition-proof, Intrinsic Safety, and Type n (combination of E7, I7, and N7)	★
E2	INMETRO Flameproof	★
I2	INMETRO Intrinsic Safety	★
E3	China Flameproof	★
I3	China Intrinsic Safety	★
EM	Technical Regulations Customs Union (EAC) Flameproof	★
IM	Technical Regulations Customs Union (EAC) Intrinsic Safety	★
KM	Technical Regulations Customs Union (EAC) Flameproof, Intrinsic Safety	★
KA <sup>(2)(3)</sup>	ATEX and CSA Explosion-proof, Intrinsically Safe, Division 2 (combination of E1, E6, I1, and I6)	★
KB <sup>(2)(3)</sup>	FM and CSA Explosion-proof, Dust Ignition-proof, Intrinsically Safe, Division 2 (combination of E5, E6, I5, and I6)	★
KC	FM and ATEX Explosion-proof, Intrinsically Safe, Division 2 (combination of E5, E1, I5, and I1)	★
KD <sup>(2)(3)</sup>	FM, CSA, and ATEX Explosion-proof, Intrinsically Safe (combination of E5, E6, E1, I5, I6, and I1)	★
KG <sup>(1)</sup>	ATEX, FM, CSA, and IECEX FISCO Intrinsic Safety (combination of IA, IE, IF, and IG)	★
K2	INMETRO Flameproof, Intrinsic Safety (Combination of E2 and I2)	★
EP	Korea Flameproof	★
IP	Korea Intrinsic Safety	★
KP	Korea Flameproof, Intrinsic Safety	★
KS	USA, Canada, IECEX, ATEX Explosion Proof, Intrinsically Safe, Dust, Non-Incendive, Type-N, Division 2	★

(1) FISCO is only available with transmitter output code F.

(2) Not available with M20 or G½ conduit entry size.

(3) RTD cable not available with this option.

### Drinking water approval

Requires 316L SST diaphragm material, glass-filled PTFE O-ring (standard), and Process Connection code E12 or F12.

Code	Description	
DW	NSF drinking water certification	★

## Shipboard approvals

This is not available with transmitter output code F.

Code	Description	
SBS	American Bureau of Shipping	★
SBV	Bureau Veritas (BV) Type Approval	★
SDN	Det Norske Veritas (DNV) Type Approval	★
SLL	Lloyds Register (LR) Type Approvals	★

## Stainless steel tagging

Code	Description	
Y2	316 SST nameplate, top tag, wire-on tag(s), and fasteners	★

## Sensor fill fluid

Only available on differential and gauge measurement types. Silicone fill fluid is standard.

Code	Description	
L1	Inert sensor fill fluid	★

## O-ring

Code	Description	
L2	Graphite-filled PTFE O-ring	★

## Bolting material

Code	Description	
L4 <sup>(1)</sup>	Austenitic 316 SST bolts	★
L5 <sup>(1)</sup>	ASTM A193, Grade B7M bolts	★
L6 <sup>(1)</sup>	Alloy K-500 bolts	★
L7 <sup>(1)(2)</sup>	ASTM A453, Class D, Grade 660 bolts	★
L8 <sup>(1)</sup>	ASTM A193, Class 2, Grade B8M bolts	★

(1) Not available with process connection option code A11.

(2) Bolts are not considered process wetted. In instances where NACE MR0175/ISO 15156 and NACE MR0103 conformance is required for bolting, L7 is the recommended bolting option.

## Digital display

Code	Description	
M5	Plantweb LCD display	★

## Wireless assembly options

This is only available with Transmitter output code A.

Code	Description	
WTA	Integral assembly to Emerson Wireless THUM™ Adapter (specified separately)	★

## Pressure testing

Code	Description	
P1 <sup>(1)</sup>	Hydrostatic testing with certificate	★

(1) Not available with DP range 0.

## Maximum static line pressure

Code	Description	
P9 <sup>(1)(2)</sup>	4500 psig (310 bar) static pressure limit	★
P0 <sup>(1)(3)</sup>	6092 psig (420 bar) static pressure limit	★

(1) Only available with Measurement Type codes 3 and 4.

(2) When assembled to remote diaphragm seal system using B11 or B12 process connections, the maximum working pressure of the system may be limited by the rating of the Rosemount 1199 Seal System selected.

(3) Requires 316L SST or Alloy C-276 diaphragm material, assemble to Rosemount 305 Integral Manifold or DIN-compliant traditional flange process connection, and bolting option L8. Limited to differential pressure ranges 2-5.

## Special cleaning

This is not available with process connection option code A11.

Code	Description	
P2	Cleaning for special services	
P3	Cleaning for special services with testing for <1PPM chlorine/fluorine	

## Calibration certification

Code	Description	
Q4	Calibration certificate	★
QP	Calibration certificate and tamper evident seal	★

## Material traceability certification

Code	Description	
Q8	Material traceability certification per EN 10204 3.1	★

### Positive material identification (PMI)

Code	Description	
Q76	PMI verification and certificate	★

### Surface finish certification

Code	Description	
Q16	Surface finish certification for sanitary remote seals	★

### Toolkit total system performance reports

Code	Description	
QZ	Remote seal system performance calculation report	★

### Quality certification for safety

Not available with output code F or X. Not available with housing code 7J.

Code	Description	
QT	Safety certified to IEC 61508 with certificate of FMEDA	★

### Transient protection

The T1 option is not needed with FISCO Product Certifications; transient protection is included in the FISCO product certification codes IA, IB, IE, IF, IG, and KG. This is not available with Housing code 00, 5A, 5J, or 7J.

Code	Description	
T1	Transient terminal block	★

### Conduit electrical connector

Code	Description	
GE	M12, 4-pin, male connector (eurofast)	★
GM	A size mini, 4-pin, male connector (minifast)	★

### NACE® certificate

NACE compliant wetted materials are identified by Materials of Construction comply with metallurgical requirements highlighted within NACE MR0175/ISO 15156 for sour oil field production environments. Environmental limits apply to certain materials. Consult latest standard for details. Selected materials also conform to NACE MR0103 for sour refining environments. Order with Q15 or Q25 to receive a NACE certificate.

Code	Description	
Q15	Certificate of compliance to NACE MR0175/ISO 15156 for wetted materials	★
Q25	Certificate of compliance to NACE MR0103 for wetted materials	★

### Cold temperature

This is not available with transmitter output code F and static pressure range 5.

Code	Description	
BRR	-58 °F (-50 °C) cold temperature start-up	★



## Rosemount 3051SF DP Flow Meters



Rosemount 3051SFA



Rosemount 3051SFC



Rosemount 3051SFP

Rosemount 3051SF Flow Meters integrate the Rosemount 3051S with industry leading primary elements. Capabilities include:

- Flow meters are factory configured to meet your application needs ([Configuration Data Sheet](#) required)
- Multivariable capabilities allow scalable flow compensation (Measurement Types 1–4)
- 4–20 mA HART®, *WirelessHART*®, and FOUNDATION™ Fieldbus protocols
- Ultra for Flow for improved flow performance across wider flow ranges
- Integral temperature measurement (Option code T)
- Advanced diagnostics (Option code DA2)
- Direct or remote mount configurations available

Additional informations

[Specifications](#)

[Relevant documents](#)

### Online product configurator

Many products are configurable online using our Product Configurator. Select the **Configure** button or visit our [website](#) to start. With this tool's built-in logic and continuous validation, you can configure your products more quickly and accurately.

### Specifications and options

See the Specifications and options section for more details on each configuration. Specification and selection of product materials, options, or components must be made by the purchaser of the equipment. See the Material selection section for more information.

## Model codes

Model codes contain the details related to each product. Exact model codes will vary; an example of a typical model code is shown in Figure 4.

Figure 4: Model Code Example

**3051C D 2 X 2 2 M5 B4**

1            2

1. Required model components (choices available on most)
2. Additional options (variety of features and functions that may be added to products)

## Optimizing lead time

The starred offerings (★) represent the most common options and should be selected for best delivery. The non-starred offerings are subject to additional delivery lead time.

## Rosemount 3051SFA Annubar™ Flow Meter



• = Available  
 — = Unavailable

- Rosemount Annubar Flow Meters reduce permanent pressure loss by creating less blockage in the pipe
- Ideal for large line size installations when cost, size and weight of the flow meter are concerns
- Typical 3051SFA model code: **3051SFA D L 060 D CHPS 2 T1 0 0 0 3 2A A 1A 3**

Specification and selection of product materials, options, or components must be made by the purchaser of the equipment.

For additional technical data and ordering information for Rosemount Annubar Primary Elements, refer to the Rosemount DP Flow meters and Primary Elements [Product Data Sheet](#).

CONFIGURE >

VIEW PRODUCT >

## Required model components

### Model

Code	Description	Measurement type		
		D	1-7	
3051SFA	Annubar Flow Meter	•	•	★

### Measurement type

Code	Description	Measurement type		
		D	1-7	
1	Fully compensated mass and energy flow calculations – differential and static pressures with temperature	—	•	★
2	Compensated flow calculations – differential and static pressures	—	•	★
3	Compensated flow calculations – differential pressure and temperature	—	•	★

Code	Description	Measurement type		
		D	1-7	
4	Compensated flow calculations – differential pressure	—	•	★
5	Process variables only (no flow calculations) – differential and static pressures with temperature	—	•	★
6	Process variables only (no flow calculations) – differential and static pressures	—	•	★
7	Process variables only (no flow calculations) – differential pressure and temperature	—	•	★
D	Differential pressure	•	—	★

**Fluid type**

Code	Description	Measurement type		
		D	1-7	
L	Liquid	•	•	★
G	Gas	•	•	★
S	Steam	•	•	★

**Line size**

Actual units are built to customer supplied pipe ID and wall dimensions. Line size codes in model are used as a nominal size and auto-selected by the sizing program.

Code	Description	Measurement type		
		D	1-7	
020	2-in. (50 mm)	•	•	★
025	2½-in. (63.5 mm)	•	•	★
030	3-in. (80 mm)	•	•	★
035	3½-in. (89 mm)	•	•	★
040	4-in. (100 mm)	•	•	★
050	5-in. (125 mm)	•	•	★
060	6-in. (150 mm)	•	•	★
070	7-in. (175 mm)	•	•	★
080	8-in. (200 mm)	•	•	★
100	10-in. (250 mm)	•	•	★
120	12-in. (300 mm)	•	•	★
140	14-in. (350 mm)	•	•	
160	16-in. (400 mm)	•	•	
180	18-in. (450 mm)	•	•	
200	20-in. (500 mm)	•	•	
240	24-in. (600 mm)	•	•	

Code	Description	Measurement type		
		D	1-7	
300	30-in. (750 mm)	•	•	
360	36-in. (900 mm)	•	•	
420	42-in. (1066 mm)	•	•	
480	48-in. (1210 mm)	•	•	
600	60-in. (1520 mm)	•	•	
720	72-in. (1820 mm)	•	•	
780	78-in. (1950 mm)	•	•	
840	84-in. (2100 mm)	•	•	
900	90-in. (2250 mm)	•	•	
960	96-in. (2400 mm)	•	•	

**Pipe I.D. range**

Code	Description	Measurement type		
		D	1-7	
Z	Custom manufactured for customer's supplied pipe ID	•	•	★

**Pipe material/mounting assembly material**

Code	Description	Measurement type		
		D	1-7	
C	Carbon steel (A105)	•	•	★
S	316 stainless steel	•	•	★
0 <sup>(1)</sup>	No mounting (customer supplied)	•	•	★
G	Chrome-Moly Grade F-11	•	•	
N	Chrome-Moly Grade F-22	•	•	
J	Chrome-Moly Grade F-91	•	•	

(1) For customer supplied mounting or isolation valve, provide relevant dimension at time of sizing and order.

**Piping orientation**

Code	Description	Measurement type		
		D	1-7	
H	Horizontal piping	•	•	★
D	Vertical piping with downwards flow	•	•	★
U	Vertical piping with upwards flow	•	•	★

**Annubar type**

Code	Description	Measurement type		
		D	1-7	
P	Pak-Lok	•	•	★
F	Flanged with opposite side support	•	•	★
L	Flange-Lok	•	•	
G	Gear-Drive Flo-Tap	•	•	
M	Manual Flo-Tap	•	•	

**Sensor material**

Code	Description	Measurement type		
		D	1-7	
S	316 Stainless steel	•	•	★
H	Alloy C-276	•	•	

**Sensor size**

Code	Description	Measurement type		
		D	1-7	
1	Sensor size 1 — Line sizes 2-in. (50 mm) to 8-in. (200 mm)	•	•	★
2	Sensor size 2 — Line sizes 6-in. (150 mm) to 96-in. (2400 mm)	•	•	★
3	Sensor size 3 — Line sizes greater than 12-in. (300 mm)	•	•	★

**Mounting type**

Code	Description	Measurement type		
		D	1-7	
T1	Compression/threaded connection	•	•	★
A1	Class 150 RF ASME B16.5	•	•	★
A3	Class 300 RF ASME B16.5	•	•	★
A6	Class 600 RF ASME B16.5	•	•	★
A9 <sup>(1)</sup>	Class 900 RF ASME B16.5	•	•	
AF <sup>(1)</sup>	Class 1500 RF ASME B16.5	•	•	
AT <sup>(1)</sup>	Class 2500 RF ASME B16.5	•	•	
D1	PN16 EN-1092-1 RF	•	•	★
D3	PN40 EN-1092-1 RF	•	•	★
D6	PN100 EN-1092-1 RF	•	•	★
R1	Class 150 RTJ ASME B16.5	•	•	

Code	Description	Measurement type		
		D	1-7	
R3	Class 300 RTJ ASME B16.5	•	•	
R6	Class 600 RTJ ASME B16.5	•	•	
R9 <sup>(1)</sup>	Class 900 RTJ ASME B16.5	•	•	
RF <sup>(1)</sup>	Class 1500 RTJ ASME B16.5	•	•	
RT <sup>(1)</sup>	Class 2500 RTJ ASME B16.5	•	•	

(1) Available in remote mount applications only.

**Opposite side support or packing gland**

Code	Description			
0	No opposite side support or packing gland (required for Pak-Lok and Flange-Lok models)	★		
<b>Opposite side support (required for flanged models)</b>				
C	NPT threaded opposite support assembly	★		
D	Welded opposite support assembly	★		
<b>Packing gland (required for Flo-Tap models)</b>				
	<b>Packing gland material</b>	<b>Rod material</b>	<b>Packing material</b>	
J <sup>(1)</sup>	Stainless steel packing gland/cage nipple	Carbon steel	PTFE	
K <sup>(1)</sup>	Stainless steel packing gland/cage nipple	Stainless steel	PTFE	
L <sup>(1)</sup>	Stainless steel packing gland/cage nipple	Carbon steel	Graphite	
N <sup>(1)</sup>	Stainless steel packing gland/cage nipple	Stainless steel	Graphite	
R	Alloy C-276 packing gland/cage nipple	Stainless steel	Graphite	

(1) The cage nipple is constructed of 304SST.

**Isolation valve for Flo-Tap models**

Code	Description	Measurement type		
		D	1-7	
0 <sup>(1)</sup>	Not applicable or customer supplied	•	•	★
1	Gate valve, carbon steel	•	•	
2	Gate valve, stainless steel	•	•	
5	Ball valve, carbon steel	•	•	
6	Ball valve, stainless steel	•	•	

(1) For customer-supplied mounting or isolation valve, provide relevant dimension at time of sizing and order

**Temperature measurement**

Code	Description	Measurement type		
		D	1-7	
T <sup>(1)</sup>	Integral RTD (not available with flanged model greater than Class 600)	•	•	★

Code	Description	Measurement type		
		D	1-7	
0	No temperature sensor	•	•	★
R <sup>(1)</sup>	Remote thermowell and RTD	•	•	

(1) A temperature sensor is required for measurement types 1, 3, 5, and 7. If the temperature sensor will be customer-supplied, contact an Emerson representative for assistance.

**Transmitter connection platform**

Code	Description	Measurement type		
		D	1-7	
3	Direct mount, integral 3-valve manifold (not available with flanged model greater than Class 600)	•	•	★
5	Direct mount, 5-valve manifold (not available with flanged model greater than Class 600)	•	•	★
6	Direct mount, high temperature 5-valve manifold (not available with flanged model greater than Class 600)	•	•	
7	Remote mount NPT connections (½-in. FNPT)	•	•	★
8	Remote mount SW connections (½-in.)	•	•	

**Differential pressure range**

Code	Description	Measurement type		
		D	1-7	
1	0 to 25 inH <sub>2</sub> O (0 to 62.16 mbar)	•	•	★
2	0 to 250 inH <sub>2</sub> O (0 to 621.60 mbar)	•	•	★
3	0 to 1000 inH <sub>2</sub> O (0 to 2.49 bar)	•	•	★

**Static pressure range**

Code	Description	Measurement type		
		D	1-7	
A <sup>(1)</sup>	None	•	•	★
D	Absolute (0 to 800 psia [0 to 55.16 bar])	—	•	★
E <sup>(2)</sup>	Absolute (0 to 3626 psia [0 to 250.0 bar])	—	•	★
J	Gage (-14.20 to 800 psig [-0.98 to 55.16 bar])	—	•	★
K <sup>(2)</sup>	Gage (-14.20 to 3626 psig [-0.98 to 250.0 bar])	—	•	★

(1) Required for measurement type codes 3, 4, 7, and D.

(2) For measurement type codes 1, 2, 5, and 6 with DP range 1, absolute limits are 0.5 to 2000 psi (0.03 to 137.9 bar) and gage limits are -14.2 to 2000 psig (-0.98 to 137.9 bar).

## Transmitter output

Code	Description	Measurement type		
		D	1-7	
A	4–20 mA with digital signal based on HART® protocol	•	•	★
F <sup>(1)</sup>	FOUNDATION™ Fieldbus protocol (requires Plantweb™ housing)	•	•	★
X <sup>(2)(3)</sup>	Wireless (requires wireless options and Wireless Plantweb housing)	•	•	★

(1) Transmitter output code F is only available with measurement type code 1, 2, 5, 6, and D.

(2) Only intrinsically safe approval codes apply.

(3) Only available with measurement types D and 6.

## Transmitter housing style

Code	Description	Material	Conduit entry size	Measurement type		
				D	1-7	
00	None (customer-supplied electrical connection)	N/A	N/A	•	—	★
1A	Plantweb™ housing	Aluminum	½–14 NPT	•	•	★
1B	Plantweb housing	Aluminum	M20 x 1.5	•	•	★
1J	Plantweb housing	SST	½–14 NPT	•	•	★
1K	Plantweb housing	SST	M20 x 1.5	•	•	★
2A	Junction box housing	Aluminum	½–14 NPT	•	—	★
2B	Junction box housing	Aluminum	M20 x 1.5	•	—	★
2E	Junction box housing with output for remote display and interface	Aluminum	½–14 NPT	•	—	★
2F	Junction box housing with output for remote display and interface	Aluminum	M20 x 1.5	•	—	★
2J	Junction box housing	SST	½–14 NPT	•	—	★
2M	Junction box housing with output for remote display and interface	SST	½–14 NPT	•	—	★
5A <sup>(1)</sup>	Wireless Plantweb housing	Aluminum	½–14 NPT	•	•	★
5J <sup>(1)</sup>	Wireless Plantweb housing	SST	½–14 NPT	•	•	★
7J <sup>(2)(3)</sup>	Quick Connect (A size mini, 4-pin male termination)	N/A	N/A	•	—	★
1C	Plantweb housing	Aluminum	G½	•	•	
1L	Plantweb housing	SST	G½	•	•	
2C	Junction box housing	Aluminum	G½	•	—	
2G	Junction box housing with output for remote display and interface	Aluminum	G½	•	—	

(1) Only available with transmitter output code X.

(2) Only intrinsically safe approval codes apply.

(3) Only available with transmitter output code A.



**Performance class**

For detailed specifications see [Specifications](#).

Code	Description	Measurement type		
		D	1-7	
<b>Measurement types 1, 2, 5, and 6</b>				
3 <sup>(1)</sup>	Ultra for Flow: 0.8% flow rate accuracy, 14:1 flow turndown, 15-year stability, 15-year limited warranty	•	•	★
5	Classic MV: 1.15% flow rate accuracy, 8:1 flow turndown, 15-year stability	—	•	★
<b>Measurement types 3, 4, 7, and D</b>				
1	Ultra: up to 0.95% flow rate accuracy, 8:1 flow turndown, 15-year stability, 15-year limited warranty	•	—	★
2	Classic: up to 1.40% flow rate accuracy, 8:1 flow turndown, 15-year stability	•	—	★
3 <sup>(1)</sup>	Ultra for Flow: 0.8% flow rate accuracy, 14:1 flow turndown, 15-year stability, 15-year limited warranty	•	•	★

(1) Only available with differential pressure ranges 2 and 3, and silicone fill fluid.

**Wireless options**

**Update rate, operating frequency and protocol**

Code	Description	Measurement type		
		D	1-7	
WA3	User configurable update rate, 2.4 GHz DSSS, IEC 62591 ( <i>WirelessHART</i> <sup>®</sup> )	•	•	★

**Omni-directional wireless antenna and SmartPower**

Long-life Power Module must be shipped separately, order Power Module 701PBKFF .

Code	Description	Measurement type		
		D	1-7	
WJ1	Remote antenna, adapter for Black Power Module (I.S. Power Module sold separately)	•	—	★
WK1	External antenna, adapter for Black Power Module (I.S. Power Module sold separately)	•	•	★
WM1	Extended range, external antenna, adapter for Black Power Module (I.S. Power Module sold separately)	•	•	★
WN1	High-gain, remote antenna, adapter for Black Power Module (I.S. Power Module sold separately)	•	•	

## Additional options

### HART® revision configuration (requires HART Protocol output code A)

Option HR7 configures the HART output to HART Revision 7. This option requires the selection of the Advanced Diagnostics (DA2) option. The device with this option can be field configured to HART Revision 5 or 7 if desired.

Code	Description	Measurement type		
		D	1-7	
HR7	Configured for HART Revision 7	•	—	★

### Extended product warranty

Code	Description	Measurement type		
		D	1-7	
WR3	3-year limited warranty	•	•	★
WR5	5-year limited warranty	•	•	★

### Pressure testing

Applies to assembled flow meter only, mounting not tested.

Code	Description	Measurement type		
		D	1-7	
P1	Hydrostatic testing with certificate	•	•	
PX	Extended hydrostatic testing	•	•	

### Special cleaning

Code	Description	Measurement type		
		D	1-7	
P2	Cleaning for special processes	•	•	

### Material testing

Code	Description	Measurement type		
		D	1-7	
V1	Dye penetrant exam	•	•	

### Material examination

Code	Description	Measurement type		
		D	1-7	
V2	Radiographic examination	•	•	

**Flow calibration**

Code	Description	Measurement type		
		D	1-7	
W1	Flow calibration (average K)	•	•	

**Special inspection**

Code	Description	Measurement type		
		D	1-7	
QC1	Visual and dimensional inspection with certificate	•	•	★
QC7	Inspection and performance certificate	•	•	★

**Surface finish**

This surface finish option is auto selected by the sizing tool as necessary.

Code	Description	Measurement type		
		D	1-7	
RL	Surface finish for low pipe Reynolds number in gas and steam	•	•	★
RH	Surface finish for high pipe Reynolds number in liquid	•	•	★

**Material traceability certification**

Instrument connections for remote mount options and isolation valves for flo-tap models are not included in the material traceability certification.

Code	Description	Measurement type		
		D	1-7	
Q8	Material traceability certificate per EN 10204:2004 3.1	•	•	★

**Positive material identification (PMI)**

For pressure retaining parts only. Isolation and instrument valves are not included.

Code	Description	Measurement type		
		D	1-7	
Q76	PMI verification and certificate	•	•	★

**Code conformance**

Code	Description	Measurement type		
		D	1-7	
J2	ANSI/ASME B31.1	•	•	
J3	ANSI/ASME B31.3	•	•	
J5 <sup>(1)(2)</sup>	NACE <sup>®</sup> MR-0175/ISO 15156	•	•	

Code	Description	Measurement type		
		D	1-7	
J6	European Pressure Directive (PED)	•	•	★
J1	Canadian Registration	•	•	
J8	Chinese Certificate of Special Equipment Type Test	•	•	

- (1) *Materials of construction comply with metallurgical requirements within NACE® MR0175/ISO 15156 for sour oil field production environments. Environmental limits apply to certain materials. Consult latest standard for details. Selected materials also conform to NACE MR0103 for sour refining environments.*
- (2) *Selecting J5 option will provide Alloy C-276 transmitter diaphragms.*

### Installed in flanged pipe spool section

Refer to Rosemount 485 [Specifications](#) section for spool section lengths and schedules.

Code	Description	Measurement type		
		D	1-7	
H3	Class 150 flanged connection with Rosemount standard length and schedule	•	•	
H4	Class 300 flanged connection with Rosemount standard length and schedule	•	•	
H5	Class 600 flanged connection with Rosemount standard length and schedule	•	•	

### Instrument connections for remote mount option

Code	Description	Measurement type		
		D	1-7	
G2	Needle valves, stainless steel	•	•	★
G6	OS and Y gate valves, stainless steel	•	•	★
G1	Needle valves, carbon steel	•	•	
G3	Needle valves, Alloy C-276	•	•	
G5	OS and Y gate valves, carbon steel	•	•	
G7	OS and Y gate valves, Alloy C-276	•	•	

### Special shipment

Requires 486 model to be ordered. Include Y1 option on 486 model also.

Code	Description	Measurement type		
		D	1-7	
Y1	Mounting hardware (shipped separately)	•	•	★

### Special dimensions

Code	Description	Measurement type		
		D	1-7	
VM	Variable mounting	•	•	

**Transmitter calibration certification**

Code	Description	Measurement type		
		D	1-7	
Q4	Calibration certificate for transmitter	•	•	★
QP	Calibration certificate and tamper evident seal	•	•	★

**Quality certification for safety**

For option code A: 4–20 mA HART® only. Not available with housing code 7J.

Code	Description	Measurement type		
		D	1-7	
QT	Safety certified to IEC 61508 with certificate of FMEDA data	•	—	★

**Product certifications**

Code	Description	Measurement type		
		D	1-7	
E1	ATEX Flameproof	•	•	★
I1	ATEX Intrinsic Safety	•	•	★
IA <sup>(1)</sup>	ATEX FISCO Intrinsic Safety	•	•	★
N1	ATEX Type n	•	•	★
ND	ATEX Dust	•	•	★
K1	ATEX Flameproof, Intrinsic Safety, Type n, Dust (combination of E1, I1, N1, and ND)	•	•	★
I2	INMETRO Intrinsic Safety	•	•	★
K2	INMETRO Flameproof, Intrinsic Safety	•	•	★
E4	TIIS Flameproof	•	•	★
E5	FM Explosion-proof, Dust Ignition-proof	•	•	★
I5	FM Intrinsically Safe; Nonincendive	•	•	★
IE <sup>(1)</sup>	FM FISCO Intrinsic Safety	•	•	★
K5	FM Explosion-proof, Dust Ignition-proof, Intrinsically Safe, Division 2 (combination of E5 and I5)	•	•	★
E6 <sup>(2)</sup>	CSA Explosion-proof, Dust Ignition-proof, Division 2	•	•	★
I6	CSA Intrinsically Safe	•	•	★
IF <sup>(1)</sup>	CSA FISCO Intrinsic Safety	•	•	★
K6 <sup>(2)</sup>	CSA Explosion-proof, Dust Ignition-proof, Intrinsically Safe, Division 2 (combination of E6 and I6)	•	•	★
E7	IECEX Flameproof, Dust Ignition-proof	•	•	★
I7	IECEX Intrinsic Safety	•	•	★
IG <sup>(1)</sup>	IECEX FISCO Intrinsic Safety	•	•	★

Code	Description	Measurement type		
		D	1-7	
N7	IECEX Type n	•	•	★
K7	IECEX Flameproof, Dust Ignition-proof, Intrinsic Safety, Type n (combination of E7, I7, and N7)	•	•	★
E3	China Flameproof	•	•	★
I3	China Intrinsic Safety	•	•	★
EP	Republic of Korea Flameproof	•	•	★
IP	Republic of Korea Intrinsic Safety	•	•	★
KP	Republic of Korea Flameproof, Intrinsic Safety	•	•	★
KA <sup>(2)</sup>	ATEX and CSA Flameproof, Intrinsically Safe, Division 2 (combination of E1, I1, E6, and I6)	•	•	★
KB <sup>(2)</sup>	FM and CSA Explosion-proof, Dust Ignition-proof, Intrinsically Safe, Division 2 (combination of E5, E6, I5, and I6)	•	•	★
EM	Technical Regulations Customs Union (EAC) Flameproof	•	•	★
IM	Technical Regulations Customs Union (EAC) Intrinsic Safety	•	•	★
KM	Technical Regulations Customs Union (EAC) Flameproof, Intrinsic Safety	•	•	★
E2	INMETRO Flameproof	•	•	★
KC	FM and ATEX Explosion-proof, Intrinsically Safe, Division 2 (combination of E5, E1, I5, and I1)	•	•	★
KD <sup>(2)</sup>	FM, CSA, and ATEX Explosion-proof, Intrinsically Safe (combination of E5, I5, E6, I6, E1, and I1)	•	•	★

(1) FISCO is only available with Transmitter output code F.

(2) Not available with M20 or G½ conduit entry size.

### Shipboard approvals

Code	Description	Measurement type		
		D	1-7	
SBS	American Bureau of Shipping	•	•	★
SBV	Bureau Veritas (BV) Type Approval	•	•	★
SDN	Det Norske Veritas (DNV) Type Approval	•	•	★
SLL	Lloyds Register (LR) Type Approval	•	•	★

### Sensor fill fluid and O-ring options

Code	Description	Measurement type		
		D	1-7	
L1	Inert sensor fill fluid	•	•	★
L2	Graphite-filled (PTFE) O-ring	•	•	★
LA	Inert sensor fill fluid and graphite-filled (PTFE) O-ring	•	•	★

**Digital display**

Not available with housing code 7J.

Code	Description	Measurement type		
		D	1-7	
M5	Plantweb™ LCD display (requires Plantweb housing)	•	•	★
M7 <sup>(1)(2)(3)</sup>	Remote mount LCD display and interface, Plantweb housing, no cable; SST bracket	•	—	★
M8 <sup>(1)(2)</sup>	Remote mount LCD display and interface, Plantweb housing, 50 ft. (15 m) cable; SST bracket	•	—	★
M9 <sup>(1)(2)</sup>	Remote mount LCD display and interface, Plantweb housing, 100 ft. (31 m) cable; SST bracket	•	—	★

(1) Not available with transmitter output code X. Only available with measurement type D.

(2) Not available with transmitter output code F, option code DA2, or option code QT.

(3) See the Rosemount 3051S [Reference Manual](#) for cable requirements. Contact an Emerson representative for additional information.

**Transient protection**

This is not available with Housing code 00, 5A, 5J, or 7J. External ground screw assembly (option code D4) is included with the T1 option. The T1 option is not needed with FISCO Product Certifications.

Code	Description	Measurement type		
		D	1-7	
T1	Transient terminal block	•	•	★

**Manifold for remote mount option**

Code	Description	Measurement type		
		D	1-7	
F2	3-valve manifold, stainless steel	•	•	★
F6	5-valve manifold, stainless steel	•	•	★
F3	3-valve manifold, Alloy C-276	•	•	
F7	5-valve manifold, Alloy C-276	•	•	

**Plantweb control functionality**

Code	Description	Measurement type		
		D	1-7	
A01	FOUNDATION™ Fieldbus advanced control function block suite	•	•	★

**Plantweb diagnostics functionality**

Code	Description	Measurement type		
		D	1-7	
D01	FOUNDATION™ Fieldbus diagnostics suite (Process Intelligence, Plugged Impulse Line diagnostic)	•	—	★

Code	Description	Measurement type		
		D	1-7	
DA2 <sup>(1)</sup>	Advanced HART <sup>®</sup> diagnostic suite (Process Intelligence, Loop Integrity, Plugged Impulse Line diagnostic, Process Alerts, Service Alerts, Variable Log, Event Log)	•	—	★

(1) Includes Hardware Adjustments (option code D1) as standard. Not available with transmitter output code X or F. Only available with measurement type D.

### Plantweb enhanced measurement functionality

Requires Rosemount Engineering Assistant to configure (to ensure correct operation download the Engineering Assistant software at [Emerson.com/Rosemount](http://Emerson.com/Rosemount)).

Code	Description	Measurement type		
		D	1-7	
H01	FOUNDATION <sup>™</sup> Fieldbus fully compensated mass flow block	•	—	★

### Cold temperature

Code	Description	Measurement type		
		D	1-7	
BRR	−58 °F (−50 °C) cold temperature start-up	—	•	★

### Alarm limit

Not available with transmitter output code F or X.

Code	Description	Measurement type		
		D	1-7	
C4	NAMUR alarm and saturation levels, high alarm	•	•	★
C5	NAMUR alarm and saturation levels, low alarm	•	•	★
C6	Custom alarm and saturation levels, high alarm (requires C1 and <a href="#">Configuration Data Sheet</a> )	•	•	★
C7	Custom alarm and saturation levels, low alarm (requires C1 and <a href="#">Configuration Data Sheet</a> )	•	•	★
C8	Low alarm (standard Rosemount alarm and saturation levels)	•	•	★

### Hardware adjustments and ground screw

Code	Description	Measurement type		
		D	1-7	
D1 <sup>(1)(2)(3)</sup>	Hardware adjustments (zero, span, alarm, security)	•	—	★
D4 <sup>(4)</sup>	External ground screw assembly	•	•	★
DA <sup>(1)(2)(3)</sup>	Hardware adjustments (zero, span, alarm, security) and external ground screw assembly	•	•	★

(1) Not available with transmitter output code X. Only available with measurement type D.

(2) Not available with transmitter output code F.

(3) Not available with housing codes 2E, 2F, 2G, 2M, 5A, 5J, or 7J.

(4) This assembly is included with options E1, E2, E3, E4,E7, EM, EP, K1, K2, K6, K7, KA, KC, KD, KP, KM, N1, N3, N7, ND, and T1.



**Conduit plug**

Code	Description	Measurement type		
		D	1-7	
DO	316 SST conduit plug	•	•	★

**Conduit electrical connector**

This is not available with housing code 5A, 5J, or 7J. Available with intrinsically Safe approvals only. For FM intrinsically Safe; Nonincendive (option code I5) or FM FISCO Intrinsically Safe (option code IE), install in accordance with Rosemount drawing 03151-1009.

Code	Description	Measurement type		
		D	1-7	
GE	M12, 4-pin, male connector (eurofast®)	•	•	
GM	A size mini, 4-pin, male connector (minifast®)	•	•	

## Rosemount 3051SFC Compact Flow Meter



• = Available  
 – = Unavailable

- Compact conditioning flow meters reduce straight piping requirements to 2D upstream and 2D downstream from most flow disturbances
- Simple installation of compact flow meters between any existing raised-face flanges
- Typical 3051SFC model code: **3051SFC 1 C S 060 N 065 T 3 2 J A 1 A 3**

Specification and selection of product materials, options, or components must be made by the purchaser of the equipment.

For additional technical data and ordering information for Rosemount Annubar Primary Elements, refer to the Rosemount DP Flow meters and Primary Elements [Product Data Sheet](#).

[CONFIGURE >](#)

[VIEW PRODUCT >](#)

### Required model components

#### Model

Code	Description	Measurement type		
		D	1-7	
3051SFC	Compact Flow Meter	•	•	

#### Measurement type

Code	Description	Measurement type		
		D	1-7	
1	Fully compensated mass and energy flow calculations – differential and static pressures with temperature	–	•	★
2	Compensated flow calculations – differential and static pressures	–	•	★
3	Compensated flow calculations – differential pressure and temperature	–	•	★
4	Compensated flow calculations – differential pressure	–	•	★
5	Process variables only (no flow calculations) – differential and static pressures with temperature	–	•	★
6	Process variables only (no flow calculations) – differential and static pressures	–	•	★
7	Process variables only (no flow calculations) – differential pressure and temperature	–	•	★
D	Differential pressure	•	–	★

#### Primary element technology

Code	Description	Measurement type		
		D	1-7	
A	Annubar averaging pitot tube	•	•	★
C	Conditioning orifice plate	•	•	★
P	Orifice plate	•	•	★

**Material type**

Code	Description	Measurement type		
		D	1-7	
S	316 SST	•	•	★

**Line size**

Code	Description	Measurement type		
		D	1-7	
005 <sup>(1)</sup>	½-in. (15 mm)	•	•	★
010 <sup>(1)</sup>	1-in. (25 mm)	•	•	★
015 <sup>(1)</sup>	1½-in. (40 mm)	•	•	★
020	2-in. (50 mm)	•	•	★
030	3-in. (80 mm)	•	•	★
040	4-in. (100 mm)	•	•	★
060	6-in. (150 mm)	•	•	★
080	8-in. (200 mm)	•	•	★
100 <sup>(2)(3)</sup>	10-in. (250 mm)	•	•	★
120 <sup>(2)(3)</sup>	12-in. (300 mm)	•	•	★

- (1) Available with primary element technology P code only.
- (2) For the 10-in. (250 mm) and 12-in. (300 mm) line sizes, the alignment ring must be ordered (Installation Accessories).
- (3) 10-in. (250 mm) and 12-in. (300 mm) line sizes not available with primary element technology code A.

**Primary element type**

Code	Description	Measurement type		
		D	1-7	
N000	Annubar sensor size 1	•	•	★
N040	0.40 Beta ratio ( $\beta$ )	•	•	★
N050	0.50 Beta ratio ( $\beta$ )	•	•	★
N065 <sup>(1)</sup>	0.65 Beta ratio ( $\beta$ )	•	•	★

- (1) For 2-in. (50 mm) line size the beta ratio is 0.60 for primary element technology code C.

**Temperature measurement**

Code	Description	Measurement type		
		D	1-7	
T <sup>(1)</sup>	Integral RTD	—	•	★
0	No temperature sensor	•	•	★

Code	Description	Measurement type		
		D	1-7	
R <sup>(1)</sup>	Remote thermowell and RTD	•	•	

(1) A temperature sensor is required for measurement types 1, 3, 5, and 7. If the temperature sensor will be customer supplied, contact an Emerson representative for assistance.

**Transmitter connection platform**

Code	Description	Measurement type		
		D	1-7	
3	Direct mount, integral 3-valve manifold	•	•	★
7	Remote mount, NPT connections	•	•	★

**Differential pressure range**

Code	Description	Measurement type		
		D	1-7	
1	0 to 25 inH <sub>2</sub> O (0 to 62.16 mbar)	•	•	★
2	0 to 250 inH <sub>2</sub> O (0 to 621.60 mbar)	•	•	★
3	0 to 1000 inH <sub>2</sub> O (0 to 2.49 bar)	•	•	★

**Static pressure range**

Code	Description	Measurement type		
		D	1-7	
A <sup>(1)</sup>	None	•	•	★
D	Absolute (0 to 800 psia [0 to 55.16 bar])	—	•	★
E <sup>(2)</sup>	Absolute (0 to 3626 psia [0 to 250.0 bar])	—	•	★
J	Gage (-14.20 to 800 psig [-0.98 to 55.16 bar])	—	•	★
K <sup>(2)</sup>	Gage (-14.20 to 3626 psig [-0.98 to 250.0 bar])	—	•	★

(1) Required for measurement type codes 3, 4, 7, and D.

(2) For measurement type codes 1, 2, 5, and 6 with DP range 1, absolute limits are 0.5 to 2000 psi (0.03 to 137.9 bar) and gage limits are -14.2 to 2000 psig (-0.98 to 137.9 bar).

**Transmitter output**

Code	Description	Measurement type		
		D	1-7	
A	4–20 mA with digital signal based on HART <sup>®</sup> protocol	•	•	★
F <sup>(1)(2)</sup>	FOUNDATION <sup>™</sup> Fieldbus protocol	•	•	★
X <sup>(3)(4)</sup>	Wireless	•	—	★

(1) Requires Plantweb housing.

(2) Transmitter output code F is only available with Measurement type code 1, 2, 5, 6, and D.

- (3) Only intrinsically safe approval codes apply.
- (4) Only available with Measurement Types D and 6.

**Transmitter housing style**

Code	Description	Material	Conduit entry size	Measurement type		
				D	1-7	
00	None (customer-supplied electrical connection)	N/A	N/A	•	—	★
1A	Plantweb™ housing	Aluminum	½–14 NPT	•	•	★
1B	Plantweb housing	Aluminum	M20 x 1.5	•	•	★
1J	Plantweb housing	SST	½–14 NPT	•	•	★
1K	Plantweb housing	SST	M20 x 1.5	•	•	★
2A	Junction box housing	Aluminum	½–14 NPT	•	—	★
2B	Junction box housing	Aluminum	M20 x 1.5	•	—	★
2E	Junction box housing with output for remote display and interface	Aluminum	½–14 NPT	•	—	★
2F	Junction box housing with output for remote display and interface	Aluminum	M20 x 1.5	•	—	★
2J	Junction box housing	SST	½–14 NPT	•	—	★
2M	Junction box housing with output for remote display and interface	SST	½–14 NPT	•	—	★
5A <sup>(1)</sup>	Wireless Plantweb housing	Aluminum	½–14 NPT	•	•	★
5J <sup>(1)</sup>	Wireless Plantweb housing	SST	½–14 NPT	•	•	★
7J <sup>(2)(3)</sup>	Quick Connect (A size mini, 4-pin male termination)	N/A	N/A	•	—	★
1C	Plantweb housing	Aluminum	G½	•	•	
1L	Plantweb housing	SST	G½	•	•	
2C	Junction box housing	Aluminum	G½	•	—	
2G	Junction box housing with output for remote display and interface	Aluminum	G½	•	—	

- (1) Only available with transmitter output code X.
- (2) Only intrinsically safe approval codes apply.
- (3) Only available with transmitter output code A.

**Performance class**

For detailed specifications see [Specifications](#).

Code	Description	Measurement type		
		D	1-7	
<b>Measurement types 1, 2, 5, and 6</b>				
3 <sup>(1)</sup>	Ultra for Flow: 0.75% flow rate accuracy, 14:1 flow turndown, 15-year stability, 15-year limited warranty	•	•	★
5	Classic MV: 1.10% flow rate accuracy, 8:1 flow turndown, 15-year stability	—	•	★

Code	Description	Measurement type		
		D	1-7	
<b>Measurement types 3, 4, 7, and D</b>				
1	Ultra: up to 0.90% flow rate accuracy, 8:1 flow turndown, 15-year stability, 15-year limited warranty	•	—	★
2	Classic: up to 1.40% flow rate accuracy, 8:1 flow turndown, 15-year stability	•	—	★
3 <sup>(1)</sup>	Ultra for Flow: 0.75% flow rate accuracy, 14:1 flow turndown, 15-year stability, 15-year limited warranty	•	•	★

(1) Only available with differential pressure ranges 2 and 3, and silicone fill fluid.

## Wireless options

### Update rate, operating frequency and protocol

Code	Description	Measurement type		
		D	1-7	
WA3	User configurable update rate, 2.4 GHz DSSS, IEC 62591 ( <i>WirelessHART</i> <sup>®</sup> )	•	•	★

### Omni-directional wireless antenna and SmartPower

Long-life Power Module must be shipped separately, order Power Module 701PBKKF .

Code	Description	Measurement type		
		D	1-7	
WJ1	Remote antenna, adapter for Black Power Module (I.S. Power Module sold separately)	•	—	★
WK1	External antenna, adapter for Black Power Module (I.S. Power Module sold separately)	•	•	★
WM1	Extended range, external antenna, adapter for Black Power Module (I.S. Power Module sold separately)	•	•	★
WN1	High-gain, remote antenna, adapter for Black Power Module (I.S. Power Module sold separately)	•	•	

## Additional options

### HART<sup>®</sup> revision configuration (requires HART Protocol output code A)

Option HR7 configures the HART output to HART Revision 7. This option requires the selection of the Advanced Diagnostics (DA2) option. The device with this option can be field configured to HART Revision 5 or 7 if desired.

Code	Description	Measurement type		
		D	1-7	
HR7	Configured for HART Revision 7	•	—	★

**Extended product warranty**

Code	Description	Measurement type		
		D	1-7	
WR3	3-year limited warranty	•	•	★
WR5	5-year limited warranty	•	•	★

**Installation accessories**

Code	Description	Measurement type		
		D	1-7	
A <sup>(1)</sup>	ANSI alignment ring (Class 150)	•	•	★
C <sup>(1)</sup>	ANSI alignment ring (Class 300)	•	•	★
D <sup>(1)</sup>	ANSI alignment ring (Class 600)	•	•	★
G	DIN alignment ring (PN 16)	•	•	★
H	DIN alignment ring (PN 40)	•	•	★
J	DIN alignment ring (PN 100)	•	•	★
B	JIS alignment ring (10K)	•	•	
R	JIS alignment ring (20K)	•	•	
S	JIS alignment ring (40K)	•	•	

(1) Only required for 10-in. (250 mm) and 12-in. (300mm) line sizes.

**Remote adapters**

Code	Description	Measurement type		
		D	1-7	
E	Flange adapters 316 SST (½-in. NPT)	•	•	★

**High temperature applications**

Code	Description	Measurement type		
		D	1-7	
T	Graphite valve packing (T <sub>max</sub> = 850 °F)	•	•	

**Flow calibration**

Code	Description	Measurement type		
		D	1-7	
WC <sup>(1)</sup>	Flow calibration, 3 pt. conditioning orifice option C	•	•	
WD <sup>(2)(3)</sup>	Flow calibration, 10 pt. conditioning orifice option C or Annubar option A	•	•	

(1) Available with primary element technology code C only.

- (2) Available with primary element technology codes C or A only.  
 (3) Consult factory for pipe schedules other than SCH 40.

### Pressure testing

Code	Description	Measurement type		
		D	1-7	
P1	Hydrostatic testing with certificate	•	•	★

### Special cleaning

Available with primary element technology C or P only.

Code	Description	Measurement type		
		D	1-7	
P2	Cleaning for special processes	•	•	

### Special inspection

Code	Description	Measurement type		
		D	1-7	
QC1	Visual and dimensional inspection with certificate	•	•	★
QC7	Inspection and performance certificate	•	•	★

### Transmitter calibration certification

Code	Description	Measurement type		
		D	1-7	
Q4	Calibration certificate for transmitter	•	•	★
QP	Calibration certificate and tamper evident seal	•	•	★

### Quality certification for safety

For option code A: 4–20 mA HART® only. Not available with housing code 7J.

Code	Description	Measurement type		
		D	1-7	
QT	Safety certified to IEC 61508 with certificate of FMEDA data	•	—	★

### Material traceability certification

Code	Description	Measurement type		
		D	1-7	
Q8	Material traceability certificate per EN 10204:2004 3.1	•	•	★



**Positive material identification (PMI)**

Code	Description	Measurement type		
		D	1-7	
Q76	PMI verification and certificate	•	•	★

**Code conformance**

Code	Description	Measurement type		
		D	1-7	
J2	ANSI/ASME B31.1	•	•	
J3	ANSI/ASME B31.3	•	•	
J4	ANSI/ASME B31.8	•	•	
J5 <sup>(1)(2)</sup>	NACE MR-0175/ISO 15156	•	•	

(1) *Materials of construction comply with metallurgical requirements within NACE® MR0175/ISO 15156 for sour oil field production environments. Environmental limits apply to certain materials. Consult latest standard for details. Selected materials also conform to NACE MR0103 for sour refining environments.*

(2) *Selecting J5 option will provide Alloy C-276 transmitter diaphragms.*

**Country certification**

Code	Description	Measurement type		
		D	1-7	
J1	Canadian Registration	•	•	
J8	Chinese certificate of special equipment type test	•	•	

**Product certifications**

Code	Description	Measurement type		
		D	1-7	
E1	ATEX Flameproof	•	•	★
I1	ATEX Intrinsic Safety	•	•	★
IA <sup>(1)</sup>	ATEX FISCO Intrinsic Safety	•	•	★
N1	ATEX Type n	•	•	★
ND	ATEX Dust	•	•	★
K1	ATEX Flameproof, Intrinsic Safety, Type n, Dust (combination of E1, I1, N1, and ND)	•	•	★
I2	INMETRO Intrinsic Safety	•	•	★
K2	INMETRO Flameproof, Intrinsic Safety	•	•	★
IB	INMETRO FISCO Intrinsic Safety	•	•	★
E4	TIIS Flameproof	•	•	★
E5	FM Explosion-proof, Dust Ignition-proof	•	•	★
I5	FM Intrinsically Safe; Nonincendive	•	•	★

Code	Description	Measurement type		
		D	1-7	
IE <sup>(1)</sup>	FM FISCO Intrinsic Safety	•	•	★
K5	FM Explosion-proof, Dust Ignition-proof, Intrinsically Safe, Division 2 (combination of E5 and I5)	•	•	★
E6 <sup>(2)</sup>	CSA Explosion-proof, Dust Ignition-proof, Division 2	•	•	★
I6	CSA Intrinsically Safe	•	•	★
IF <sup>(1)</sup>	CSA FISCO Intrinsic Safety	•	•	★
K6 <sup>(2)</sup>	CSA Explosion-proof, Dust Ignition-proof, Intrinsically Safe, Division 2 (combination of E6 and I6)	•	•	★
E7	IECEX Flameproof, Dust Ignition-proof	•	•	★
I7	IECEX Intrinsic Safety	•	•	★
IG <sup>(1)</sup>	IECEX FISCO Intrinsic Safety	•	•	★
K7	IECEX Flameproof, Dust Ignition-proof, Intrinsic Safety, Type n (combination of E7, I7, and N7)	•	•	★
E3	China Flameproof	•	•	★
I3	China Intrinsic Safety	•	•	★
EP	Republic of Korea Flameproof	•	•	★
IP	Republic of Korea Intrinsic Safety	•	•	★
KP	Republic of Korea Flameproof, Intrinsic Safety	•	•	★
KA <sup>(2)</sup>	ATEX and CSA Flameproof, Intrinsically Safe, Division 2 (combination of E1, I1, E6, and I6)	•	•	★
KB <sup>(2)</sup>	FM and CSA Explosion-proof, Dust Ignition-proof, Intrinsically Safe, Division 2 (combination of E5, E6, I5, and I6)	•	•	★
EM	Technical Regulations Customs Union (EAC) Flameproof	•	•	★
IM	Technical Regulations Customs Union (EAC) Intrinsic Safety	•	•	★
KM	Technical Regulations Customs Union (EAC) Flameproof, Intrinsic Safety	•	•	★
E2	INMETRO Flameproof	•	•	★
KC	FM and ATEX Explosion-proof, Intrinsically Safe, Division 2 (combination of E5, E1, I5, and I1)	•	•	★
KD <sup>(2)</sup>	FM, CSA, and ATEX Explosion-proof, Intrinsically Safe (combination of E5, I5, E6, I6, E1, and I1)	•	•	★
KL	USA, Canada, IECEX, ATEX Intrinsic Safety Combination	•	•	★
KS	USA, Canada, IECEX, ATEX Explosion Proof, Intrinsically Safe, Dust, Non-incendive, Type N, Div. 2	•	•	★

(1) FISCO is only available with Transmitter output code F.

(2) Not available with M20 or G½ conduit entry size.

**Shipboard approvals**

Code	Description	Measurement type		
		D	1-7	
SBS	American Bureau of Shipping	•	•	★
SBV	Bureau Veritas (BV) Type Approval	•	•	★
SDN	Det Norske Veritas (DNV) Type Approval	•	•	★
SLL	Lloyds Register (LR) Type Approval	•	•	★

**Sensor fill fluid and O-ring options**

Code	Description	Measurement type		
		D	1-7	
L1	Inert sensor fill fluid	•	•	★
L2	Graphite-filled (PTFE) O-ring	•	•	★
LA	Inert sensor fill fluid and graphite-filled (PTFE) O-ring	•	•	★

**Digital display**

Not available with housing code 7J.

Code	Description	Measurement type		
		D	1-7	
M5	Plantweb™ LCD display (requires Plantweb housing)	•	•	★
M7 <sup>(1)(2)(3)</sup>	Remote mount LCD display and interface, Plantweb housing, no cable; SST bracket	•	—	★
M8 <sup>(1)(2)</sup>	Remote mount LCD display and interface, Plantweb housing, 50 ft. (15 m) cable; SST bracket	•	—	★
M9 <sup>(1)(2)</sup>	Remote mount LCD display and interface, Plantweb housing, 100 ft. (31 m) cable; SST bracket	•	—	★

(1) Not available with transmitter output code X. Only available with measurement type D.

(2) Not available with transmitter output code F, option code DA2, or option code QT.

(3) See the Rosemount 3051S [Reference Manual](#) for cable requirements. Contact an Emerson representative for additional information.

**Transient protection**

This is not available with Housing code 00, 5A, 5J, or 7J. External ground screw assembly (option code D4) is included with the T1 option. The T1 option is not needed with FISCO Product Certifications.

Code	Description	Measurement type		
		D	1-7	
T1	Transient terminal block	•	•	★

**Manifold for remote mount option**

Code	Description	Measurement type		
		D	1-7	
F2	3-valve manifold, SST	•	•	★
F6	5-valve manifold, SST	•	•	★

**Plantweb control functionality**

Code	Description	Measurement type		
		D	1-7	
A01	FOUNDATION™ Fieldbus advanced control function block suite	•	•	★

**Plantweb diagnostics functionality**

Code	Description	Measurement type		
		D	1-7	
D01	FOUNDATION™ Fieldbus diagnostics suite (Process Intelligence, Plugged Impulse Line diagnostic)	•	—	★
DA2 <sup>(1)</sup>	Advanced HART® diagnostic suite (Process Intelligence, Loop Integrity, Plugged Impulse Line diagnostic, Process Alerts, Service Alerts, Variable Log, Event Log)	•	—	★

(1) Includes Hardware Adjustments (option code D1) as standard. Not available with transmitter output code X or F. Only available with measurement type D.

**Plantweb enhanced measurement functionality**

Requires Rosemount Engineering Assistant to configure (to ensure correct operation download the Engineering Assistant software at [Emerson.com/Rosemount](http://Emerson.com/Rosemount)).

Code	Description	Measurement type		
		D	1-7	
H01	FOUNDATION™ Fieldbus fully compensated mass flow block	•	—	★

**Cold temperature**

Code	Description	Measurement type		
		D	1-7	
BRR	−58 °F (−50 °C) cold temperature start-up	—	•	★
BR6	−76 °F (−60 °C) cold temperature operation	•	—	★

**Alarm limit**

Not available with transmitter output code F or X.

Code	Description	Measurement type		
		D	1-7	
C4	NAMUR alarm and saturation levels, high alarm	•	•	★
C5	NAMUR alarm and saturation levels, low alarm	•	•	★
C6	Custom alarm and saturation levels, high alarm (requires C1 and <a href="#">Configuration Data Sheet</a> )	•	•	★
C7	Custom alarm and saturation levels, low alarm (requires C1 and <a href="#">Configuration Data Sheet</a> )	•	•	★
C8	Low alarm (standard Rosemount alarm and saturation levels)	•	•	★

**Hardware adjustments and ground screw**

Code	Description	Measurement type		
		D	1-7	
D1 <sup>(1)(2)(3)</sup>	Hardware adjustments (zero, span, alarm, security)	•	—	★
D4 <sup>(4)</sup>	External ground screw assembly	•	•	★
DA <sup>(1)(2)(3)</sup>	Hardware adjustments (zero, span, alarm, security) and external ground screw assembly	•	—	★

- (1) Not available with output code X. Only available with measurement type D.
- (2) Not available with output protocol code F.
- (3) Not available with housing codes 2E, 2F, 2G, 2M, 5A, 5J, or 7J.
- (4) This assembly is included with options EP, KP, E1, N1, K1, ND, E4, E7, K7, E3, KA, KC, KD, IA, T1, EM, and KM.

**Conduit plug**

Code	Description	Measurement type		
		D	1-7	
DO	316 SST conduit plug	•	•	★

**Conduit electrical connector**

Not available with housing code 5A, 5J, or 7J. Available with Intrinsically Safe approvals only. For FM Intrinsically Safe; Nonincendive (option code I5) or FM FISCO Intrinsically Safe (option code IE), install in accordance with Rosemount drawing 03151-1009.

Code	Description	Measurement type		
		D	1-7	
ZE	M12, 4-pin, male connector (eurofast <sup>®</sup> )	•	•	★
ZM	A size mini, 4-pin, male connector (minifast <sup>®</sup> )	•	•	★

## Rosemount 3051SFP Integral Orifice Flow Meter



- Precision honed pipe section for increased accuracy in small line sizes
- Self-centering plate design prevents alignment errors that magnify measurement inaccuracies in small line sizes
- Typical 3051SFP model code: **3051SFP 1 F 010 W3 S 0150 D3 1 JA 1A 3 M5**

Specification and selection of product materials, options, or components must be made by the purchaser of the equipment.

For additional technical data and ordering information for Rosemount Annubar Primary Elements, refer to the Rosemount DP Flow meters and Primary Elements [Product Data Sheet](#).

[CONFIGURE >](#)

[VIEW PRODUCT >](#)

- = Available
- = Unavailable

### Required model components

#### Model

Code	Description	Measurement type		
		D	1-7	
3051SFP	Integral Orifice Flow Meter	•	•	★

#### Measurement type

Code	Description	Measurement type		
		D	1-7	
1	Fully compensated mass and energy flow calculations – differential and static pressures with temperature	—	•	★
2	Compensated flow calculations – differential and static pressures	—	•	★
3	Compensated flow calculations – differential pressure and temperature	—	•	★
4	Compensated flow calculations – differential pressure	—	•	★
5	Process variables only (no flow calculations) – differential and static pressures with temperature	—	•	★
6	Process variables only (no flow calculations) – differential and static pressures	—	•	★
7	Process variables only (no flow calculations) – differential pressure and temperature	—	•	★
D	Differential pressure	•	—	★

#### Material type and body

Code	Description	Measurement type		
		D	1-7	
F	316 SST, enhanced support body	•	•	★

**Line size**

Code	Description	Measurement type		
		D	1-7	
005	½-in. (15 mm)	•	•	★
010	1-in. (25 mm)	•	•	★
015	1½-in. (40 mm)	•	•	★

**Process connection**

Code	Description	Measurement type		
		D	1-7	
T1	NPT female body (not available with thermowell and RTD)	•	•	★
S1 <sup>(1)</sup>	Socket weld body (not available with thermowell and RTD)	•	•	★
P1	Pipe ends: NPT threaded	•	•	★
P2	Pipe ends: beveled	•	•	★
D1	Pipe ends: flanged, PN16 EN-1092-1 RF, slip-on	•	•	★
D2	Pipe ends: flanged, PN40 EN-1092-1 RF, slip-on	•	•	★
D3	Pipe ends: flanged, PN100 EN-1092-1 RF, slip-on	•	•	★
W1	Pipe ends: flanged, Class 150 RF ASME B16.5, weld-neck	•	•	★
W3	Pipe ends: flanged, Class 300 RF ASME B16.5, weld-neck	•	•	★
W6	Pipe ends: flanged, Class 600 RF ASME B16.5, weld-neck	•	•	★
W9	Pipe ends: flanged, Class 900 RF ASME B16.5, weld-neck	•	•	★
A1	Pipe ends: flanged, Class 150 RF ASME B16.5, slip-on	•	•	
A3	Pipe ends: flanged, Class 300 RF ASME B16.5, slip-on	•	•	
A6	Pipe ends: flanged, Class 600 RF ASME B16.5, slip-on	•	•	
R1	Pipe ends: flanged, Class 150 RTJ ASME B16.5, slip-on	•	•	
R3	Pipe ends: flanged, Class 300 RTJ ASME B16.5, slip-on	•	•	
R6	Pipe ends: flanged, Class 600 RTJ ASME B16.5, slip-on	•	•	
R9	Pipe ends: flanged, Class 900 RTJ ASME B16.5, weld-neck	•	•	

(1) To improve pipe perpendicularity for gasket sealing, socket diameter is smaller than standard pipe O.D.

**Orifice plate material**

Code	Description	Measurement type		
		D	1-7	
S	316/316L SST	•	•	★
H	Alloy C-276	•	•	
M	Alloy 400	•	•	

## Bore size option

Code	Description	Measurement type		
		D	1-7	
0066	0.066-in. (1.68 mm) for ½-in. pipe	•	•	★
0109	0.109-in. (2.77 mm) for ½-in. pipe	•	•	★
0160	0.160-in. (4.06 mm) for ½-in. pipe	•	•	★
0196	0.196-in. (4.98 mm) for ½-in. pipe	•	•	★
0260	0.260-in. (6.60 mm) for ½-in. pipe	•	•	★
0340	0.340-in. (8.64 mm) for ½-in. pipe	•	•	★
0150	0.150-in. (3.81 mm) for 1-in. pipe	•	•	★
0250	0.250-in. (6.35 mm) for 1-in. pipe	•	•	★
0345	0.345-in. (8.76 mm) for 1-in. pipe	•	•	★
0500	0.500-in. (12.70 mm) for 1-in. pipe	•	•	★
0630	0.630-in. (16.00 mm) for 1-in. pipe	•	•	★
0800	0.800-in. (20.32 mm) for 1-in. pipe	•	•	★
0295	0.295-in. (7.49 mm) for 1½-in. pipe	•	•	★
0376	0.376-in. (9.55 mm) for 1½-in. pipe	•	•	★
0512	0.512-in. (13.00 mm) for 1½-in. pipe	•	•	★
0748	0.748-in. (19.00 mm) for 1½-in. pipe	•	•	★
1022	1.022-in. (25.96 mm) for 1½-in. pipe	•	•	★
1184	1.184-in. (30.07 mm) for 1½-in. pipe	•	•	★
0010	0.010-in. (0.25 mm) for ½-in. pipe	•	•	
0014	0.014-in. (0.36 mm) for ½-in. pipe	•	•	
0020	0.020-in. (0.51 mm) for ½-in. pipe	•	•	
0034	0.034-in. (0.86 mm) for ½-in. pipe	•	•	
XXXX	Special bore size (X.XXX-in.)	•	•	

## Transmitter connection platform

Code	Description	Measurement type		
		D	1-7	
D3	Direct mount, 3-valve manifold, SST	•	•	★
D5	Direct mount, 5-valve manifold, SST	•	•	★
R3	Remote mount, 3-valve manifold, SST	•	•	★
R5	Remote mount, 5-valve manifold, SST	•	•	★
D4	Direct mount, 3-valve manifold, Alloy C-276	•	•	
D6	Direct mount, 5-valve manifold, Alloy C-276	•	•	



Code	Description	Measurement type		
		D	1-7	
R4	Remote mount, 3-valve manifold, Alloy C-276	•	•	
R6	Remote mount, 5-valve manifold, Alloy C-276	•	•	

**Differential pressure range**

Code	Description	Measurement type		
		D	1-7	
1	0 to 25 inH <sub>2</sub> O (0 to 62.16 mbar)	•	•	★
2	0 to 250 inH <sub>2</sub> O (0 to 621.60 mbar)	•	•	★
3	0 to 1000 inH <sub>2</sub> O (0 to 2.49 bar)	•	•	★

**Static pressure range**

Code	Description	Measurement type		
		D	1-7	
A <sup>(1)</sup>	None	•	•	★
D	Absolute (0 to 800 psia [0 to 55.16 bar])	—	•	★
E <sup>(2)</sup>	Absolute (0 to 3626 psia [0 to 250.0 bar])	—	•	★
J	Gage (-14.20 to 800 psig [-0.98 to 55.16 bar])	—	•	★
K <sup>(2)</sup>	Gage (-14.20 to 3626 psig [-0.98 to 250.0 bar])	—	•	★

- (1) Required for measurement type codes 3, 4, 7, and D.
- (2) For measurement type codes 1, 2, 5, and 6 with DP range 1, absolute limits are 0.5 to 2000 psi (0.03 to 137.9 bar) and gage limits are -14.2 to 2000 psig (-0.98 to 137.9 bar).

**Transmitter output**

Code	Description	Measurement type		
		D	1-7	
A	4–20 mA with digital signal based on HART® protocol	•	•	★
F <sup>(1)</sup>	FOUNDATION™ Fieldbus protocol (requires Plantweb™ housing)	•	•	★
χ <sup>(2)(3)</sup>	Wireless (requires wireless options and Wireless Plantweb housing)	•	•	★

- (1) Transmitter output code F is only available with measurement type code 1, 2, 5, 6, and D.
- (2) Only intrinsically safe approval codes apply.
- (3) Only available with measurement types D and 6.

**Transmitter housing style**

Code	Description	Material	Conduit entry size	Measurement type		
				D	1-7	
00	None (customer-supplied electrical connection)	N/A	N/A	•	—	★
1A	Plantweb™ housing	Aluminum	½–14 NPT	•	•	★

Code	Description	Material	Conduit entry size	Measurement type		
				D	1-7	
1B	Plantweb housing	Aluminum	M20 x 1.5	•	•	★
1J	Plantweb housing	SST	½–14 NPT	•	•	★
1K	Plantweb housing	SST	M20 x 1.5	•	•	★
2A	Junction box housing	Aluminum	½–14 NPT	•	—	★
2B	Junction box housing	Aluminum	M20 x 1.5	•	—	★
2E	Junction box housing with output for remote display and interface	Aluminum	½–14 NPT	•	—	★
2F	Junction box housing with output for remote display and interface	Aluminum	M20 x 1.5	•	—	★
2J	Junction box housing	SST	½–14 NPT	•	—	★
2M	Junction box housing with output for remote display and interface	SST	½–14 NPT	•	—	★
5A <sup>(1)</sup>	Wireless Plantweb housing	Aluminum	½–14 NPT	•	•	★
5J <sup>(1)</sup>	Wireless Plantweb housing	SST	½–14 NPT	•	•	★
7J <sup>(2)(3)</sup>	Quick Connect (A size mini, 4-pin male termination)	N/A	N/A	•	—	★
1C	Plantweb housing	Aluminum	G½	•	•	
1L	Plantweb housing	SST	G½	•	•	
2C	Junction box housing	Aluminum	G½	•	—	
2G	Junction box housing with output for remote display and interface	Aluminum	G½	•	—	

(1) Only available with transmitter output code X.

(2) Only intrinsically safe approval codes apply.

(3) Only available with transmitter output code A.

**Performance class**

For detailed specifications see [Specifications](#).

Code	Description	Measurement type		
		D	1-7	
<b>Measurement types 1, 2, 5, and 6</b>				
3 <sup>(1)</sup>	Ultra for Flow: 0.95% flow rate accuracy, 14:1 flow turndown, 15-year stability, 15-year limited warranty	•	•	★
5	Classic MV: 1.25% flow rate accuracy, 8:1 flow turndown, 15-year stability	—	•	★
<b>Measurement types 3, 4, 7, and D</b>				
1	Ultra: up to 1.05% flow rate accuracy, 8:1 flow turndown, 15-year stability, 15-year limited warranty	•	—	★
2	Classic: up to 1.50% flow rate accuracy, 8:1 flow turndown, 15-year stability	•	—	★
3 <sup>(1)</sup>	Ultra for Flow: 0.95% flow rate accuracy, 14:1 flow turndown, 15-year stability, 15-year limited warranty	•	•	★

(1) Only available with differential pressure ranges 2 and 3, and silicone fill fluid.

## Wireless options

### Update rate, operating frequency and protocol

Code	Description	Measurement type		
		D	1-7	
WA3	User configurable update rate, 2.4 GHz DSSS, IEC 62591 ( <i>WirelessHART</i> <sup>®</sup> )	•	•	★

### Omni-directional wireless antenna and SmartPower

Long-life Power Module must be shipped separately, order Power Module 701PBKFF .

Code	Description	Measurement type		
		D	1-7	
WJ1	Remote antenna, adapter for Black Power Module (I.S. Power Module sold separately)	•	—	★
WK1	External antenna, adapter for Black Power Module (I.S. Power Module sold separately)	•	•	★
WM1	Extended range, external antenna, adapter for Black Power Module (I.S. Power Module sold separately)	•	•	★
WN1	High-gain, remote antenna, adapter for Black Power Module (I.S. Power Module sold separately)	•	•	

## Additional options

### HART<sup>®</sup> revision configuration (requires HART Protocol output code A)

Option HR7 configures the HART output to HART Revision 7. This option requires the selection of the Advanced Diagnostics (DA2) option. The device with this option can be field configured to HART Revision 5 or 7 if desired.

Code	Description	Measurement type		
		D	1-7	
HR7	Configured for HART Revision 7	•	—	★

### Extended product warranty

Code	Description	Measurement type		
		D	1-7	
WR3	3-year limited warranty	•	•	★
WR5	5-year limited warranty	•	•	★

### Transmitter/body bolt material

Code	Description	Measurement type		
		D	1-7	
G	High temperature option (850 °F [454 °C])	•	•	

**Temperature sensor**

Thermowell material is the same as the body material.

Code	Description	Measurement type		
		D	1-7	
T	Thermowell and RTD	•	•	★

**Optional connection**

Code	Description	Measurement type		
		D	1-7	
G1	DIN 19213 transmitter connection	•	•	★

**Pressure testing**

Does not apply to process connection codes T1 and S1. Option P1 may not be ordered in combination with P2.

Code	Description	Measurement type		
		D	1-7	
P1	Hydrostatic testing with certificate	•	•	

**Special cleaning**

Code	Description	Measurement type		
		D	1-7	
P2	Cleaning for special processes	•	•	

**Material testing**

Code	Description	Measurement type		
		D	1-7	
V1	Dye penetrant exam	•	•	

**Material examination**

Code	Description	Measurement type		
		D	1-7	
V2	Radiographic examination (available only with process connection code W1, W3, and W6)	•	•	

**Flow calibration**

This is not available for bore sizes 0010, 0014, 0020, 0034, 0066, or 0109. This option does not apply to process connection codes T1 and S1.

Code	Description	Measurement type		
		D	1-7	
WD	Discharge coefficient verification	•	•	

**Special inspection**

Code	Description	Measurement type		
		D	1-7	
QC1	Visual and dimensional inspection with certificate	•	•	★
QC7	Inspection and performance certificate	•	•	★

**Material traceability certification**

Code	Description	Measurement type		
		D	1-7	
Q8	Material traceability certificate per EN 10204:2004 3.1	•	•	★

**Positive material identification (PMI)**

Code	Description	Measurement type		
		D	1-7	
Q76	PMI verification and certificate	•	•	★

**Code conformance**

Not available with DIN process connection codes D1, D2, or D3.

Code	Description	Measurement type		
		D	1-7	
J2	ANSI/ASME B31.1	•	•	
J3	ANSI/ASME B31.3	•	•	

**Material conformance**

Materials of construction comply with metallurgical requirements within NACE® MR0175/ISO 15156 for sour oil field production environments. Environmental limits apply to certain materials. Consult latest standard for details. Selected materials also conform to NACE MR0103 for sour refining environments.

Selecting J5 option will provide Alloy C-276 transmitter diaphragms.

Code	Description	Measurement type		
		D	1-7	
J5	NACE MR-0175/ISO 15156	•	•	

**Country certification**

Code	Description	Measurement type		
		D	1-7	
J6	European Pressure Directive (PED)	•	•	★
J1	Canadian Registration	•	•	

**Transmitter calibration certification**

Code	Description	Measurement type		
		D	1-7	
Q4	Calibration certificate for transmitter	•	•	★

**Quality certification for safety**

For option code A: 4–20 mA HART® only. Not available with housing code 7J.

Code	Description	Measurement type		
		D	1-7	
QT	Safety certified to IEC 61508 with certificate of FMEDA data	•	—	★

**Product certifications**

Code	Description	Measurement type		
		D	1-7	
E1	ATEX Flameproof	•	•	★
I1	ATEX Intrinsic Safety	•	•	★
IA <sup>(1)</sup>	ATEX FISCO Intrinsic Safety	•	•	★
N1	ATEX Type n	•	•	★
ND	ATEX Dust	•	•	★
K1	ATEX Flameproof, Intrinsic Safety, Type n, Dust (combination of E1, I1, N1, and ND)	•	•	★
I2	INMETRO Intrinsic Safety	•	•	★
IB	INMETRO FISCO Intrinsic Safety	•	•	★

Code	Description	Measurement type		
		D	1-7	
K2	INMETRO Flameproof, Intrinsic Safety	•	•	★
E4	TIIS Flameproof	•	•	★
E5	FM Explosion-proof, Dust Ignition-proof	•	•	★
I5	FM Intrinsically Safe; Nonincendive	•	•	★
IE <sup>(1)</sup>	FM FISCO Intrinsic Safety	•	•	★
K5	FM Explosion-proof, Dust Ignition-proof, Intrinsically Safe, Division 2 (combination of E5 and I5)	•	•	★
E6 <sup>(2)</sup>	CSA Explosion-proof, Dust Ignition-proof, Division 2	•	•	★
I6	CSA Intrinsically Safe	•	•	★
IF <sup>(1)</sup>	CSA FISCO Intrinsic Safety	•	•	★
K6 <sup>(2)</sup>	CSA Explosion-proof, Dust Ignition-proof, Intrinsically Safe, Division 2 (combination of E6 and I6)	•	•	★
E7	IECEX Flameproof, Dust Ignition-proof	•	•	★
I7	IECEX Intrinsic Safety	•	•	★
IG <sup>(1)</sup>	IECEX FISCO Intrinsic Safety	•	•	★
N7	IECEX Type n	•	•	★
K7	IECEX Flameproof, Dust Ignition-proof, Intrinsic Safety, Type n (combination of E7, I7, and N7)	•	•	★
E3	China Flameproof	•	•	★
I3	China Intrinsic Safety	•	•	★
EP	Republic of Korea Flameproof	•	•	★
IP	Republic of Korea Intrinsic Safety	•	•	★
KP	Republic of Korea Flameproof, Intrinsic Safety	•	•	★
KA <sup>(2)</sup>	ATEX and CSA Flameproof, Intrinsically Safe, Division 2 (combination of E1, I1, E6, and I6)	•	•	★
KB <sup>(2)</sup>	FM and CSA Explosion-proof, Dust Ignition-proof, Intrinsically Safe, Division 2 (combination of E5, E6, I5, and I6)	•	•	★
EM	Technical Regulations Customs Union (EAC) Flameproof	•	•	★
IM	Technical Regulations Customs Union (EAC) Intrinsic Safety	•	•	★
KM	Technical Regulations Customs Union (EAC) Flameproof, Intrinsic Safety	•	•	★
E2	INMETRO Flameproof	•	•	★
KC	FM and ATEX Explosion-proof, Intrinsically Safe, Division 2 (combination of E5, E1, I5, and I1)	•	•	★
KD <sup>(2)</sup>	FM, CSA, and ATEX Explosion-proof, Intrinsically Safe (combination of E5, I5, E6, I6, E1, and I1)	•	•	★

(1) FISCO is only available with Transmitter output code F.

(2) Not available with M20 or G½ conduit entry size.

### Shipboard approvals

Code	Description	Measurement type		
		D	1-7	
SBS	American Bureau of Shipping	•	•	★
SBV	Bureau Veritas (BV) Type Approval	•	•	★
SDN	Det Norske Veritas (DNV) Type Approval	•	•	★
SLL	Lloyds Register (LR) Type Approval	•	•	★

### Sensor fill fluid and O-ring options

Code	Description	Measurement type		
		D	1-7	
L1	Inert sensor fill fluid	•	•	★
L2	Graphite-filled (PTFE) O-ring	•	•	★
LA	Inert sensor fill fluid and graphite-filled (PTFE) O-ring	•	•	★

### Digital display

Not available with housing code 7J.

Code	Description	Measurement type		
		D	1-7	
M5	Plantweb™ LCD display (requires Plantweb housing)	•	•	★
M7 <sup>(1)(2)(3)</sup>	Remote mount LCD display and interface, Plantweb housing, no cable, SST bracket	•	—	★
M8 <sup>(2)(3)</sup>	Remote mount LCD display and interface, Plantweb housing, 50 ft. (15 m) cable, SST bracket	•	—	★
M9 <sup>(2)(3)</sup>	Remote mount LCD display and interface, Plantweb housing, 100 ft. (31 m) cable, SST bracket	•	—	★

(1) See the Rosemount 3051S [Reference Manual](#) for cable requirements. Contact an Emerson representative for additional information.

(2) Not available with output code F, option code DA2, or option code QT.

(3) Not available with output code X.

### Transient protection

This is not available with Housing code 00, 5A, 5J, or 7J. External ground screw assembly (option code D4) is included with the T1 option. The T1 option is not needed with FISCO Product Certifications.

Code	Description	Measurement type		
		D	1-7	
T1	Transient terminal block	•	•	★
T2	Terminal block with WAGO spring clamp terminals	•	•	★
T3	Transient terminal block with WAGO spring clamp terminals	•	•	★



**Plantweb control functionality**

Code	Description	Measurement type		
		D	1-7	
A01	FOUNDATION™ Fieldbus advanced control function block suite	•	•	★

**Plantweb diagnostics functionality**

Code	Description	Measurement type		
		D	1-7	
D01	FOUNDATION™ Fieldbus diagnostics suite (Process Intelligence, Plugged Impulse Line diagnostic)	•	—	★
DA2 <sup>(1)</sup>	Advanced HART® diagnostic suite (Process Intelligence, Loop Integrity, Plugged Impulse Line diagnostic, Process Alerts, Service Alerts, Variable Log, Event Log)	•	—	★

(1) Includes Hardware Adjustments (option code D1) as standard. Not available with transmitter output code X or F. Only available with measurement type D.

**Plantweb enhanced measurement functionality**

Requires Rosemount Engineering Assistant to configure (to ensure correct operation download the Engineering Assistant software at [Emerson.com/Rosemount](http://Emerson.com/Rosemount)).

Code	Description	Measurement type		
		D	1-7	
H01	FOUNDATION™ Fieldbus fully compensated mass flow block	•	—	★

**Cold temperature**

Code	Description	Measurement type		
		D	1-7	
BRR	-58 °F (-50 °C) cold temperature start-up	—	•	★

**Alarm limit**

Not available with transmitter output code F or X.

Code	Description	Measurement type		
		D	1-7	
C4	NAMUR alarm and saturation levels, high alarm	•	—	★
C5	NAMUR alarm and saturation levels, low alarm	•	—	★
C6	Custom alarm and saturation levels, high alarm (requires C1 and <a href="#">Configuration Data Sheet</a> )	•	—	★
C7	Custom alarm and saturation levels, low alarm (requires C1 and <a href="#">Configuration Data Sheet</a> )	•	—	★
C8	Low alarm (standard Rosemount alarm and saturation levels)	•	—	★

### Hardware adjustments and ground screw

Code	Description	Measurement type		
		D	1-7	
D1 <sup>(1)(2)(3)</sup>	Hardware adjustments (zero, span, alarm, security)	•	—	★
D4 <sup>(4)</sup>	External ground screw assembly	•	•	★
DA <sup>(1)(2)(3)</sup>	Hardware adjustments (zero, span, alarm, security) and external ground screw assembly	•	•	★

(1) Not available with transmitter output code X. Only available with measurement type D.

(2) Not available with transmitter output code F.

(3) Not available with housing codes 2E, 2F, 2G, 2M, 5A, 5J, or 7J.

(4) This assembly is included with options E1, E2, E3, E4,E7, EM, EP, K1, K2, K6, K7, KA, KC, KD, KP, KM, N1, N3, N7, ND, and T1.

### Conduit plug

Code	Description	Measurement type		
		D	1-7	
DO	316 SST conduit plug	•	•	★

### Conduit electrical connector

This is not available with housing code 5A, 5J, or 7J. Available with intrinsically Safe approvals only. For FM intrinsically Safe; Nonincendive (option code I5) or FM FISCO Intrinsically Safe (option code IE), install in accordance with Rosemount drawing 03151-1009.

Code	Description	Measurement type		
		D	1-7	
GE	M12, 4-pin, male connector (eurofast®)	•	•	
GM	A size mini, 4-pin, male connector (minifast®)	•	•	

# Rosemount 3051S Electronic Remote Sensor (ERS™) System



The Rosemount 3051S ERS System is a flexible, 2-wire, 4-20 mA HART® architecture that calculates differential pressure (DP) electronically using two pressure sensors that are linked together with a non-proprietary electrical wire.

Ideal applications for the Rosemount 3051S ERS System include tall vessels and distillation columns that have traditionally required long lengths of capillary or impulse piping. When used in these types of applications, the Rosemount 3051S ERS System can deliver:

- More accurate and repeatable DP measurements
- Faster time response
- Simplified installations
- Reduced maintenance

VIEW PRODUCT >

## Online product configurator

Many products are configurable online using our Product Configurator. Select the **Configure** button or visit our [website](#) to start. With this tool's built-in logic and continuous validation, you can configure your products more quickly and accurately.

## Specifications and options

See the Specifications and options section for more details on each configuration. Specification and selection of product materials, options, or components must be made by the purchaser of the equipment. See the Material selection section for more information.

## Model codes

Model codes contain the details related to each product. Exact model codes will vary; an example of a typical model code is shown in [Figure 5](#).

**Figure 5: Model Code Example**

**3051C D 2 X 2 2 M5 B4**

1            2

1. Required model components (choices available on most)
2. Additional options (variety of features and functions that may be added to products)

## Optimizing lead time

The starred offerings (★) represent the most common options and should be selected for best delivery. The non-starred offerings are subject to additional delivery lead time.

## How to order

### Procedure

1. Choose two Rosemount 3051S ERS Transmitter models. These may be any combination of Rosemount 3051SAM and Rosemount 3051SAL models.

#### Rosemount 3051SAM



Coplanar

In-line

#### Rosemount 3051SAL



Coplanar

In-line

2. Decide which model will be the ERS Primary (4–20 mA loop termination and optional LCD display) and which will be the ERS Secondary. This will be specified by the “Configuration Type” code in each model number.



A. Secondary

B. Primary

3. Specify two full model numbers per the desired configuration.

3051SAM1ST2A2E11A2A

3051SAL1PG4AA1A1020DFF71DA00M5

## Rosemount 3051SAM Transmitter for ERS Applications



- Coplanar and in-line sensor module platforms
- Variety of process connections including threaded NPT, flanges, manifolds, and Rosemount 1199 Remote Seals
- Available with 15-year stability and 15-year limited warranty

Specification and selection of product materials, options, or components must be made by the purchaser of the equipment.

### Required model components

#### Model

Code	Description
3051SAM	Scalable ERS Measurement Transmitter

#### Performance class

The Rosemount 3051S ERS System offers three performance class options; Classic, Ultra, and Enhanced ERS system performance. The Classic and Ultra performance classes are suited to lower static pressure and stable temperature conditions. The Enhanced ERS system performance class provides better performance across temperature (–40 to 185 °F) with improved performance at higher static pressure.

Code	Description	
1	Ultra: 0.025% span accuracy, 200:1 rangedown, 15-year stability, 15-year limited warranty	★
2	Classic: 0.035% span accuracy, 150:1 rangedown, 15-year stability	★
4	Enhanced ERS System performance, 15-year stability, 15-year limited warranty	★

#### Configuration type

Code	Description	
P	ERS - primary	★
S	ERS - secondary	★

#### Pressure type

Code	Description		
	Module	Sensor	
G	Coplanar	Gauge	★
T	In-Line	Gauge	★
E	In-Line	Absolute	★

Code	Description		
	Module	Sensor	
A	Coplanar	Absolute	

**Pressure range**

The pressure range should be specified based on the maximum static pressure, not differential pressure.

Code	Description				
	Coplanar gauge	In-line gauge	In-line absolute	Coplanar absolute	
1A	N/A	-14.7 to 30 psig (-1.01 to 2.06 bar)	0 to 30 psia (0 to 2.06 bar)	0 to 30 psia (0 to 2.06 bar)	★
2A	-250 to 250 inH <sub>2</sub> O (-621.60 to 621.60 mbar)	-14.7 to 150 psig (-1.01 to 10.34 bar)	0 to 150 psia (0 to 10.34 bar)	0 to 150 psia (0 to 10.34 bar)	★
3A	-393 to 1000 inH <sub>2</sub> O (-0.97 to 2.48 bar)	-14.7 to 800 psig (-1.01 to 55.15 bar)	0 to 800 psia (0 to 55.15 bar)	0 to 800 psia (0 to 55.15 bar)	★
4A	-14.2 to 300 psig (-0.97 to 20.68 bar)	-14.7 to 4000 psig (-1.01 to 275.79 bar)	0 to 4000 psia (0 to 275.79 bar)	0 to 4000 psia (0 to 275.79 bar)	★
5A	-14.2 to 2000 psig (-0.97 to 137.89 bar)	-14.7 to 10000 psig (-1.01 to 689.47 bar)	0 to 10000 psia (0 to 689.47 bar)	N/A	★

**Isolating diaphragm**

Code	Description	
2 <sup>(1)</sup>	316L stainless steel (SST)	★
3 <sup>(1)</sup>	Alloy C-276	★
4 <sup>(1)(2)</sup>	Alloy 400	
5 <sup>(2)(3)</sup>	Tantalum	
6 <sup>(1)(2)</sup>	Gold-plated Alloy 400 (includes graphite-filled PTFE O-Ring)	
7 <sup>(1)(2)</sup>	Gold-plated 316L SST	

(1) Materials of construction comply with metallurgical requirements highlighted within NACE MR 0175/ISO 15156 for sour oil field production environments. Environmental limits apply to certain materials. Consult latest standard for details. Selected materials also conform to NACE MR 0103 for sour refining environments. Order with Q15 or Q25 to receive a NACE certificate.

(2) Not available with pressure sensor/module codes T or E.

(3) Tantalum diaphragm material is only available with Pressure Sensor/Module code G.

**Process connection**

Code	Description		
	Coplanar module type	In-line module type	
A11 <sup>(1)</sup>	Assemble to Rosemount 305 Manifold	Assemble to Rosemount 306 Manifold	★
A12 <sup>(1)</sup>	Assemble to Rosemount 304 or AMF Manifold with SST traditional flange	Assemble AMF Manifold to ½-14 NPT female process connection	★

Code	Description		
	Coplanar module type	In-line module type	
A15 <sup>(1)</sup>	Assemble to Rosemount 304 or AMF manifold to SST traditional flange with alloy C-276 drain vents	N/A	★
A22 <sup>(1)</sup>	Assemble to Rosemount 304 or AMF manifold to SST coplanar flange	N/A	★
B11 <sup>(1)(2)</sup>	Assemble to one Rosemount 1199 Remote Diaphragm Seal with SST transmitter flange	Assemble to one Rosemount 1199 Remote Diaphragm	★
E11	Coplanar flange (CS), ¼–18 NPT, 316 SST drain vents	½–14 NPT female	★
E12	Coplanar flange (SST), ¼–18 NPT, 316 SST drain vents	N/A	★
E13 <sup>(3)</sup>	Coplanar flange (Cast C-276), ¼–18 NPT, Alloy C-276 drain vents	N/A	★
E14	Coplanar flange (Cast Alloy 400), ¼–18 NPT, Alloy 400/K-500 drain vents	N/A	★
E15 <sup>(3)</sup>	Coplanar flange (SST), ¼–18 NPT, Alloy C-276 drain vents	N/A	★
E16 <sup>(3)</sup>	Coplanar flange (CS), ¼–18 NPT, Alloy C-276 drain vents	N/A	★
E21	Coplanar flange (CS), RC ¼, 316 SST drain vents	N/A	★
E22	Coplanar flange (SST), RC ¼, 316 SST drain vents	N/A	★
E23 <sup>(3)</sup>	Coplanar flange (Cast C-276), RC ¼, Alloy C-276 drain vents	N/A	★
E24	Coplanar flange (Cast Alloy 400), RC ¼, alloy 400/K-500 drain vents	N/A	★
E25 <sup>(3)</sup>	Coplanar flange (SST), RC ¼, Alloy C-276 drain vents	N/A	★
E26 <sup>(3)</sup>	Coplanar flange (CS), RC ¼, Alloy C-276 drain vents	N/A	★
F12	Traditional flange (SST), ¼–18 NPT, 316 SST drain vents	N/A	★
F13 <sup>(3)</sup>	Traditional flange (Cast C-276), ¼–18 NPT, Alloy C-276 drain vents	N/A	★
F14	Traditional flange (Cast Alloy 400), ¼–18 NPT, Alloy 400/K-500 drain vents	N/A	★
F15 <sup>(3)</sup>	Traditional flange (SST), ¼–18 NPT, Alloy C-276 drain vents	N/A	★
F22	Traditional flange (SST), RC ¼, 316 SST drain vents	N/A	★
F23 <sup>(3)</sup>	Traditional flange (Cast C-276), RC¼, Alloy C-276 drain vents	N/A	★
F24	Traditional flange (Cast Alloy 400), RC¼, Alloy 400/K500 drain vents	N/A	★
F25	Traditional flange (SST), RC ¼, Alloy C-276 drain vents	N/A	★
F52	DIN-compliant traditional flange (SST), ¼–18 NPT, 316 drain vents, 7 to 16-in. bolting	N/A	★

Code	Description		
	Coplanar module type	In-line module type	
G11	Vertical mount level flange (SST), 2-in. ASME Class 150, 316 SST drain vents	G½ A DIN 16288 male (range 1–4 only)	★
G12	Vertical mount level flange (SST), 2-in. ASME Class 300, 316 SST drain vents	N/A	★
G21	Vertical mount level flange (SST), 3-in. ASME Class 150, 316 SST drain vents	N/A	★
G22	Vertical mount level flange (SST), 3-in. ASME Class 300, 316 SST drain vents	N/A	★
G31	Vertical mount level flange (SST), DIN-DN 50 PN 40, 316 SST drain vents	N/A	★
G41	Vertical mount level flange (SST), DIN-DN 80 PN 40, 316 SST drain vents	N/A	★
P11	N/A	Level flange (SST), 2-in. ASME Class 150	★
P12	N/A	Level flange (SST), 2-in. ASME Class 300	★
P21	N/A	Level flange (SST), 3-in. ASME Class 150	★
P22	N/A	Level flange (SST), 3-in. ASME Class 300	★
P31	N/A	Level flange (SST), DIN-DN 50 PN 40	★
F11	Traditional flange (CS), ¼–18 NPT, 316 SST drain vents	Non-threaded instrument flange (I-Flange)	
F32	Bottom vent traditional flange (SST), ¼–18 NPT, 316 SST drain vents	N/A	
F42	Bottom vent traditional flange (SST), RC¼, 316 SST drain vents	N/A	
F62	DIN-compliant traditional flange (316 SST), ¼–18 NPT, 316 drain vents, M10 bolting	N/A	
F72	DIN-compliant traditional flange (316 SST), ¼–18 NPT, 316 drain vents, M12 bolting	N/A	

- (1) "Assemble to" items are specified separately and require a completed model number.
- (2) Consult an Emerson representative for performance specifications.
- (3) Materials of construction comply with metallurgical requirements highlighted within NACE MR 0175/ISO 15156 for sour oil field production environments. Environmental limits apply to certain materials. Consult latest standard for details. Selected materials also conform to NACE MR 0103 for sour refining environments. Order with Q15 or Q25 to receive a NACE certificate.

**Transmitter output**

Code	Description	
A	4–20 mA with digital signal based on HART® protocol	★

**Housing style**

Code	Description	Material	Conduit entry size	
<b>Housings for ERS primary - configuration type code P</b>				
1A	Plantweb™ housing	Aluminum	½–14 NPT	★



Code	Description	Material	Conduit entry size	
<b>Housings for ERS primary - configuration type code P</b>				
1B	Plantweb housing	Aluminum	M20 x 1.5 (CM 20)	★
1J	Plantweb housing	SST	½–14 NPT	★
1K	Plantweb housing	SST	M20 x 1.5 (CM 20)	★
2E	Junction box with remote display output	Aluminum	½–14 NPT	★
2F	Junction box with remote display output	Aluminum	M20 x 1.5 (CM 20)	★
2M	Junction box with remote display output	SST	½–14 NPT	★
1C	Plantweb housing	Aluminum	G½	
1L	Plantweb housing	SST	G½	
2G	Junction box with remote display output	Aluminum	G½	
<b>Housings for ERS secondary - configuration type code S</b>				
2A	Junction box	Aluminum	½–14 NPT	★
2B	Junction box	Aluminum	M20 x 1.5 (CM 20)	★
2J	Junction box	SST	½–14 NPT	★
2C	Junction box	Aluminum	G½	

### Additional options

#### Extended product warranty

Code	Description	
WR3	3-year limited warranty	★
WR5	5-year limited warranty	★

#### ERS connection cable

Code	Description	
R02	25 ft. (7.62 m) of ERS cable (gray color)	
R05	50 ft. (15.2 m) of ERS cable (gray color)	★
R10	100 ft. (30.5 m) of ERS cable (gray color)	★
R15	150 ft. (45.72 m) of ERS cable (gray color)	★
R20 <sup>(1)</sup>	200 ft. (60.96 m) of ERS cable (gray color)	
R22 <sup>(2)</sup>	225 ft. (68.58 m) of ERS cable (gray color)	
R30	300 ft. (91.44 m) of ERS cable (gray color)	
R40	400 ft. (121.92 m) of ERS cable (gray color)	
R50	500 ft. (152.4 m) of ERS cable (gray color)	
H02	25 ft. (7.62 m) of ERS cable (blue color)	
H05	50 ft. (15.2 m) of ERS cable (blue color)	

Code	Description	
H10	100 ft. (30.5 m) of ERS cable (blue color)	
H15	150 ft. (45.7 m) of ERS cable (blue color)	
H20 <sup>(1)</sup>	200 ft. (60.96 m) of ERS cable (blue color)	
H22 <sup>(2)</sup>	225 ft. (68.58 m) of ERS cable (blue color)	
J02	25 ft. (7.62 m) of ERS armored cable	
J05	50 ft. (15.2 m) of ERS armored cable	
J07	75 ft. (22.8 m) of ERS armored cable	
J10	100 ft. (30.5 m) of ERS armored cable	
J12 <sup>(2)</sup>	125 ft. (38.1 m) of ERS armored cable	

(1) Maximum cable distance for SIS installations. See Rosemount 3051S ERS [Reference Manual](#) for more information.

(2) Maximum cable distance for IS (Intrinsically safe) installations. Other options may not be valid at longer distances.

### Mounting bracket

Code	Description	
B1 <sup>(1)</sup>	Traditional flange bracket, CS, 2-in. pipe	★
B2 <sup>(1)</sup>	Traditional flange bracket, CS, panel	★
B3 <sup>(1)</sup>	Traditional flange flat bracket, CS, 2-in. pipe	★
B4	Bracket, all SST, 2-in. pipe and panel	★
B7 <sup>(1)</sup>	Traditional flange bracket, B1 with SST bolts	★
B8 <sup>(1)</sup>	Traditional flange bracket, B2 with SST bolts	★
B9 <sup>(1)</sup>	Traditional flange bracket, B3 with SST bolts	★
BA <sup>(1)</sup>	Traditional flange bracket, B1, all SST	★
BC <sup>(1)</sup>	Traditional flange bracket, B3, all SST	★

(1) Not available with pressure sensor/module codes T or E.

### Special configuration (software)

Code	Description	
C1 <sup>(1)</sup>	Customer software configuration (Configuration Data Sheet must be completed)	★
C3	Gauge pressure calibration on Rosemount 3051SAM A4 only	★
C4 <sup>(1)</sup>	NAMUR alarm and saturation levels, high alarm	★
C5 <sup>(1)</sup>	NAMUR alarm and saturation levels, low alarm	★
C6 <sup>(1)</sup>	Custom alarm and saturation levels, high alarm (requires C1 and Configuration Data Sheet)	★
C7 <sup>(1)</sup>	Custom alarm and saturation levels, low alarm (requires C1 and Configuration Data Sheet)	★
C8 <sup>(1)</sup>	Low alarm (standard Rosemount alarm and saturation levels)	★

(1) Not available with Configuration Type code S.

**Special configuration (hardware)**

Code	Description	
D2 <sup>(1)</sup>	½–14 NPT flange adapters	★
D4 <sup>(2)</sup>	External ground screw assembly	★
D5 <sup>(1)</sup>	Delete transmitter drain/vent valves (install plugs)	★
D7 <sup>(1)</sup>	Coplanar flange without drain/vent ports	
D9 <sup>(1)</sup>	RC ½ flange adapters	

(1) Not available with Process Connection code A11.

(2) This assembly is included with options E1, N1, K1, ND, E4, E7, N7, K7, E2, KA, KC, KD, K2, T1, EP, and KP.

**Product certifications**

Code	Description	
E1	ATEX Flameproof	★
I1	ATEX Intrinsic Safety	★
N1	ATEX Type n	★
K1	ATEX Flameproof and Intrinsically Safe, Type n, Dust	★
ND	ATEX Dust	★
E4	TIIS Flameproof	★
E5	FM Explosion-proof, Dust Ignition-proof	★
I5	FM Intrinsically Safe, Division 2	★
K5	FM Explosion-proof, Dust Ignition-proof, Intrinsically Safe, Division 2	★
E6 <sup>(1)</sup>	CSA Explosion-proof, Dust Ignition-proof, Division 2	★
I6	CSA Intrinsically Safe	★
K6 <sup>(1)</sup>	CSA Explosion-proof, Dust Ignition-proof, Intrinsically Safe, Division 2	★
E7	IECEX Flameproof	★
I7	IECEX Intrinsic Safety	★
N7	IECEX Type n	★
K7	IECEX Flameproof, Intrinsic Safety, Type n	★
E2	INMETRO Flameproof	★
I2	INMETRO Intrinsically Safe	★
K2	INMETRO Flameproof, Intrinsic Safety, Type n	★
E3	China Flameproof	★
I3	China Intrinsic Safety, Dust Ignition-proof	★
EP	Korea Flameproof	★
IP	Korea Intrinsic Safety	★
KP	Korea Flameproof, Intrinsic Safety	★
EM	Technical Regulations Customs Union (EAC) Flameproof	★

Code	Description	
IM	Technical Regulations Customs Union (EAC) Intrinsic Safety	★
KM	Technical Regulations Customs Union (EAC) Flameproof, Intrinsic Safety	★
KA <sup>(1)</sup>	ATEX and CSA Flameproof, Intrinsically Safe, Division 2	★
KB <sup>(1)</sup>	FM and CSA Explosion-proof, Dust Ignition-proof, Intrinsically Safe, Division 2	★
KC	FM and ATEX Explosion-proof, Intrinsically Safe, Division 2	★
KD <sup>(1)</sup>	FM, CSA, and ATEX Explosion-proof, Intrinsically Safe	★

(1) Not available with M20 or G½ conduit entry size.

**Shipboard approvals**

Code	Description	
SBS	American Bureau of Shipping (ABS) Type Approval	★
SBV	Bureau Veritas (BV) Type Approval	★
SDN	Det Norske Veritas (DNV) Type Approval	★
SLL	Lloyds Register (LR) Type Approval	★

**Calibration certification**

Code	Description	
Q4	Calibration certificate	★
QP	Calibration certificate and tamper evident seal	★

**Material traceability certification**

Code	Description	
Q8	Material traceability certification per EN 10204 3.1	★

**Quality certification for safety**

This option is not available with output code F or X. This option is not available with housing code 7J.

Code	Description	
QT	Safety certified to IEC 61508 with certificate of FMEDA data	★

**Surface finish certification**

Code	Description	
Q16	Surface finish certification for hygienic remote seals	★

### Toolkit performance reports

The QZ report quantifies the performance of the entire ERS system. One report is provided per ERS system. The QZ option is specified on the primary transmitter (configuration type code P).

Code	Description	
QZ	Remote seal system performance calculation report	★

### Terminal blocks

This is not available with configuration type code S.

Code	Description	
T1	Transient terminal block	★

### Sensor fill fluid

Silicone fill fluid is standard.

Code	Description	
L1	Inert sensor fill fluid	★

### O-ring

Code	Description	
L2	Graphite-filled PTFE O-ring	★

### Bolting material

Code	Description	
L4	Austenitic 316 SST bolts	★
L5 <sup>(1)</sup>	ASTM A 193, Grade B7M bolts	★
L6	Alloy K-500 bolts	★
L7 <sup>(1)</sup>	ASTM A 453, Class D, Grade 660 bolts	★
L8	ASTM A 193, Class 2, Grade B8M bolts	★

(1) *Materials of construction comply with metallurgical requirements highlighted within NACE MR 0175/ISO 15156 for sour oil field production environments. Environmental limits apply to certain materials. Consult latest standard for details. Selected materials also conform to NACE MR 0103 for sour refining environments. Order with Q15 or Q25 to receive a NACE certificate.*

### Display type (ERS primary only)

This is not available with configuration type code S.

Code	Description	
M5	Plantweb™ LCD display	★
M7 <sup>(1)</sup>	Remote mount LCD display and interface, Plantweb housing, no cable, SST bracket	★
M8	Remote mount LCD display and interface, Plantweb housing, 50 ft. (15.2 m) cable, SST bracket	★

Code	Description	
M9	Remote mount LCD display and interface, Plantweb housing, 100 ft. (30.5 m) cable, SST bracket	★

(1) See the Rosemount 3051S [Reference Manual](#) for cable requirements. Contact an Emerson representative for additional information.

**Pressure testing**

Code	Description	
P1	Hydrostatic testing with certificate	

**Special cleaning**

This is not available with process connection code A11.

Code	Description	
P2	Cleaning for special services	
P3	Cleaning for less than 1 PPM Chlorine/Fluorine	

**NACE certificate**

Materials of construction comply with metallurgical requirements highlighted within NACE® MR 0175/ISO 15156 for sour oil field production environments. Environmental limits apply to certain materials. Consult latest standard for details. Selected materials also conform to NACE MR 0103 for sour refining environments. Order with Q15 or Q25 to receive a NACE certificate.

Code	Description	
Q15	Certificate of compliance to NACE MR0175/ISO 15156 for wetted materials	★
Q25	Certificate of compliance to NACE MR0103 for wetted materials	★

**Positive material identification (PMI)**

Code	Description	
Q76	PMI verification and certificate	★

**Rosemount 3051SAL Transmitter for ERS Applications**



- Integrated transmitter and direct mount seal in a single model number
- Variety of process connections including flanged, threaded, and hygienic remote seals
- Available with 15-year limited warranty

Specification and selection of product materials, options, or components must be made by the purchaser of the equipment.

A Rosemount 3051SAL Scalable ERS Level Transmitter consists of three parts. First, specify the transmitter model codes found below. Finish the model number by specifying all desired options from the Additional Options section.

## Required model components

### Model

Code	Transmitter type	
3051SAL	Scalable level transmitter	★

### Performance class

The Rosemount 3051S ERS System offer three performance class options; Classic, Ultra, and Enhanced ERS system performance. The Classic and Ultra performance classes are suited to lower static pressure and stable temperature conditions. The Enhanced ERS system performance class provides better performance across temperature (–40 to 185 °F) with improved performance at higher static pressure.

Code	Description	
1	Ultra: 0.055% span accuracy, 150:1 rangedown, 15-year limited warranty	★
2	Classic: 0.065% span accuracy, 150:1 rangedown	★
4	Enhanced ERS system performance, 15-year limited warranty	★

### Configuration type

Code	Description	
P	ERS - primary	★
S	ERS - secondary	★

### Pressure type

Code	Description		
	Module	Sensor	
G	Coplanar	Gauge	★
T	In-Line	Gauge	★
E	In-Line	Absolute	★
A	Coplanar	Absolute	

### Pressure range

The pressure range should be specified based on the maximum static pressure, not differential pressure.

Code	Description				
	Coplanar gauge	In-line gauge	In-line absolute	Coplanar absolute	
1A	N/A	–14.7 to 30 psig (–1.01 to 2.06 bar)	0 to 30 psia (0 to 2.06 bar)	0 to 30 psia (0 to 2.06 bar)	★
2A	–250 to 250 inH <sub>2</sub> O (–621.60 to 621.60 mbar)	–14.7 to 150 psig (–1.01 to 10.34 bar)	0 to 150 psia (0 to 10.34 bar)	0 to 150 psia (0 to 10.34 bar)	★
3A	–393 to 1000 inH <sub>2</sub> O (–0.97 to 2.48 bar)	–14.7 to 800 psig (–1.01 to 55.15 bar)	0 to 800 psia (0 to 55.15 bar)	0 to 800 psia (0 to 55.15 bar)	★

Code	Description				
	Coplanar gauge	In-line gauge	In-line absolute	Coplanar absolute	
4A	-14.2 to 300 psig (-0.97 to 20.68 bar)	-14.7 to 4000 psig (-1.01 to 275.79 bar)	0 to 4000 psia (0 to 275.79 bar)	0 to 4000 psia (0 to 275.79 bar)	★
5A	-14.2 to 2000 psig (-0.97 to 137.89 bar)	-14.7 to 10000 psig (-1.01 to 689.47 bar)	0 to 10000 psia (0 to 689.47 bar)	N/A	★

**Transmitter output**

Code	Description	
A	4–20 mA with digital signal based on HART® protocol	★

**Housing style**

Code	Description	Material	Conduit entry size	
<b>Housings for ERS primary - configuration type code P</b>				
1A	Plantweb™ housing	Aluminum	½–14 NPT	★
1B	Plantweb housing	Aluminum	M20 x 1.5 (CM 20)	★
1J	Plantweb housing	SST	½–14 NPT	★
1K	Plantweb housing	SST	M20 x 1.5 (CM 20)	★
2E	Junction box with remote display output	Aluminum	½–14 NPT	★
2F	Junction box with remote display output	Aluminum	M20 x 1.5 (CM 20)	★
2M	Junction box with remote display output	SST	½–14 NPT	★
1C	Plantweb housing	Aluminum	G½	
1L	Plantweb housing	SST	G½	
2G	Junction box with remote display output	Aluminum	G½	
<b>Housings for ERS secondary - configuration type code S</b>				
2A	Junction box	Aluminum	½–14 NPT	★
2B	Junction box	Aluminum	M20 x 1.5 (CM 20)	★
2J	Junction box	SST	½–14 NPT	★
2C	Junction box	Aluminum	G½	

**Seal system type**

See Seal system type in Rosemount DP Level [Product Data Sheet](#) for more detail.

Code	Description		
<b>Coplanar pressure module type</b>			
1	Single direct mount seal system	Welded-repairable	★
2	Single direct mount seal system	All welded	★



Code	Description
<b>In-line pressure module type</b>	
1	Single direct mount seal system All welded ★

**High side connection type**

Code	Description
<b>Single direct mount seal system (between transmitter and remote seal)</b>	
0	No extension ★
2	2-in. (50 mm) extension ★
4	4-in. (100 mm) extension ★
5 <sup>(1)</sup>	Thermal Optimizer ★
6 <sup>(2)</sup>	Thermal Range Expander - Silicone 200 secondary fill fluid ★
7 <sup>(2)(3)</sup>	Thermal Range Expander - SYLTHERM™ XLT secondary fill fluid ★
8 <sup>(2)</sup>	Thermal Range Expander - Tri-Therm 300 secondary fill fluid

(1) Maximum working pressure (MWP) of the Thermal Optimizer is 4000 psi (275 bar). See , , or for Thermal Optimizer temperature limits.

(2) Maximum working pressure (MWP) of the Thermal Range Expander is 3750 psi (258.6 bar).




(3) Thermal Range Expander with SYLTHERM XLT secondary fill fluid is not recommended for use in vacuum applications below 6 psia (400 mbar-a).

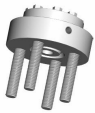


**Low side connection type (reference pressure connection)**

Code	Low side connection type (reference pressure connection)
<b>Single direct mount seal system</b>	
00	None (In-line style sensor) ★
20	316L SST isolator/SST transmitter flange ★
30	Alloy C-276 isolator/SST transmitter flange ★

**Seal fill fluid**

**Seal style**

Seal type	Model	Process connection
	Flush Flanged (FF) Seal	2-in./DN 50/50A 3-in./DN 80/80A 4-in./ DN 100/100A
	Extended Flanged (EF) Seal	3-in./DN 80/80A 4-in./DN 100/100A
	Remote Flanged (RF) Seal	½-in. ¾-in 1-in./DN 25/25A 1 ½-in./DN 40/40A

Seal type	Model	Process connection
	RC Remote Flanged Seal - Ring Type Joint (RTJ) gasket surface	½-in. ¾-in. 1-in. 1½-in.
	SC Hygienic Tri Clamp Seal	1½-in. 2-in. 3-in.
	SS Hygienic Tan Spud Seal	4-in.

### Additional options

#### Extended product warranty

Code	Description	
WR3	3-year limited warranty	★
WR5	5-year limited warranty	★

#### ERS connection cable

The pressure range should be specified based on the maximum static pressure, not differential pressure.

Code	Description	
R02	25 ft. (7.62 m) of ERS cable (gray color)	
R05	50 ft. (15.2 m) of ERS cable (gray color)	★
R10	100 ft. (30.5 m) of ERS cable (gray color)	★
R15	150 ft. (45.72 m) of ERS cable (gray color)	★
R20 <sup>(1)</sup>	200 ft. (60.96 m) of ERS cable (gray color)	
R22 <sup>(2)</sup>	225 ft. (68.58 m) of ERS cable (gray color)	
R30	300 ft. (91.44 m) of ERS cable (gray color)	
R40	400 ft. (121.92 m) of ERS cable (gray color)	
R50	500 ft. (152.4 m) of ERS cable (gray color)	
H02	25 ft. (7.62 m) of ERS cable (blue color)	
H05	50 ft. (15.2 m) of ERS cable (blue color)	
H10	100 ft. (30.5 m) of ERS cable (blue color)	
H15	150 ft. (45.7 m) of ERS cable (blue color)	
H20 <sup>(1)</sup>	200 ft. (60.96 m) of ERS cable (blue color)	
H22 <sup>(1)</sup>	225 ft. (68.58 m) of ERS cable (blue color)	
J02	25 ft. (7.62 m) of armored ERS cable	

Code	Description
J05	50 ft. (15.2 m) of armored ERS cable
J07	75 ft. (22.8 m) of armored ERS cable
J10	100 ft. (30.5 m) of armored ERS cable
J12 <sup>(2)</sup>	125 ft. (38.1 m) of armored ERS cable

(1) *Maximum cable distance for SIS installations. See "Safety Instrumented Systems (SIS) Certification" section of Rosemount 3051S ERS Reference Manual for more information.*

(2) *Maximum cable distance for IS (Intrinsically safe) installations. Other options may not be valid at longer distances.*

### Software configuration

This is not available with configuration type code S.

Code	Description
C1	Custom software configuration (requires Configuration Data Sheet) ★

### Gauge pressure calibration

Code	Description
C3	Gauge pressure calibration on Rosemount 3051SAL A4 only ★

### Alarm limit

This is not available with configuration type code S.

Code	Description
C4	NAMUR alarm and saturation levels, high alarm ★
C5	NAMUR alarm and saturation levels, low alarm ★
C6	Custom alarm and saturation levels, high alarm (requires C1 and Configuration Data Sheet) ★
C7	Custom alarm and saturation levels, low alarm (requires C1 and Configuration Data Sheet) ★
C8	Low alarm (standard Rosemount alarm and saturation levels) ★

### Ground screw

This assembly is included with options EP, KP, E1, N1, K1, ND, E4, E7, N7, K7, E2, KA, KC, KD, K2, T1, E3, EM, KM.

Code	Description
D4	External ground screw assembly ★

### Conduit plug

Code	Description
DO	316 SST conduit plug ★

## Product certifications

Code	Description	
E1	ATEX Flameproof	★
I1	ATEX Intrinsic Safety	★
N1	ATEX Type n	★
K1	ATEX Flameproof and Intrinsically Safe, Type n, Dust	★
ND	ATEX Dust	★
E4	TIIS Flameproof	★
E5	FM Explosion-proof, Dust Ignition-proof	★
I5	FM Intrinsically Safe, Division 2	★
K5	FM Explosion-proof, Dust Ignition-proof, Intrinsically Safe, Division 2	★
E6 <sup>(1)</sup>	CSA Explosion-proof, Dust Ignition-proof, Division 2	★
I6	CSA Intrinsically Safe	★
K6 <sup>(1)</sup>	CSA Explosion-proof, Dust Ignition-proof, Intrinsically Safe, Division 2	★
E7	IECEX Flameproof	★
I7	IECEX Intrinsic Safety	★
N7	IECEX Type n	★
K7	IECEX Flameproof, Intrinsic Safety, Type n	★
E2	INMETRO Flameproof	★
I2	INMETRO Intrinsically Safe	★
K2	INMETRO Flameproof, Intrinsic Safety, Type n	★
E3	China Flameproof	★
I3	China Intrinsic Safety, Dust Ignition-proof	★
EP	Korea Flameproof	★
IP	Korea Intrinsic Safety	★
KP	Korea Flameproof, Intrinsic Safety	★
EM	Technical Regulations Customs Union (EAC) Flameproof	★
IM	Technical Regulations Customs Union (EAC) Intrinsic Safety	★
KM	Technical Regulations Customs Union (EAC) Flameproof, Intrinsic Safety	★
KA <sup>(1)</sup>	ATEX and CSA Flameproof, Intrinsically Safe, Division 2	★
KB <sup>(1)</sup>	FM and CSA Explosion-proof, Dust Ignition-proof, Intrinsically Safe, Division 2	★
KC	FM and ATEX Explosion-proof, Intrinsically Safe, Division 2	★
KD <sup>(1)</sup>	FM, CSA, and ATEX Explosion-proof, Intrinsically Safe	★

(1) Not available with M20 or G½ conduit entry size.

### Shipboard approvals

Code	Description	
SBS	American Bureau of Shipping (ABS) Type Approval	★
SBV	Bureau Veritas (BV) Type Approval	★
SDN	Det Norske Veritas (DNV) Type Approval	★
SLL	Lloyds Register (LR) Type Approval	★

### Sensor fill fluid

Silicone fill fluid is standard.

Code	Description	
L1	Inert sensor fill fluid	★

### O-ring

Code	Description	
L2	Graphite-filled PTFE O-ring	★

### Bolting material

Code	Description	
L4	Austenitic 316 SST bolts	★

### Display type (ERS primary only)

This is not available with configuration type code S.

Code	Description	
M5	Plantweb™ LCD display	★
M7 <sup>(1)</sup>	Remote mount LCD display and interface, Plantweb housing, no cable, SST bracket	★
M8	Remote mount LCD display and interface, Plantweb housing, 50 ft. (15.2 m) cable, SST bracket	★
M9	Remote mount LCD display and interface, Plantweb housing, 100 ft. (30.5 m) cable, SST bracket	★

(1) See the Rosemount 3051S [Reference Manual](#) for cable requirements. Contact an Emerson representative for additional information.

### Pressure testing

Code	Description	
P1	Hydrostatic testing with certificate	

**Special cleaning**

This is not available with process connection code A11.

Code	Description
P2	Cleaning for special services
P3	Cleaning for less than 1 PPM Chlorine/Fluorine

**Calibration certification**

Code	Description
Q4	Calibration certificate
QP	Calibration certificate and tamper evident seal

**Material traceability certification**

Code	Description
Q8	Material traceability certification per EN 10204 3.1

**Quality certification for safety**

This option is not available with output code F or X. This option is not available with housing code 7J.

Code	Description
QT	Safety certified to IEC 61508 with certificate of FMEDA data

**Toolkit performance reports**

The QZ report quantifies the performance of the entire ERS system. One report is provided per ERS system. The QZ option is specified on the primary transmitter (configuration type code P).

Code	Description
QZ	Remote seal system performance calculation report

**Transient protection**

This is not available with configuration type code S.

Code	Description
T1	Transient terminal block

**NACE certificate**

Materials of construction comply with metallurgical requirements highlighted within NACE MR 0175/ISO 15156 for sour oil field production environments. Environmental limits apply to certain materials. Consult latest standard for details. Selected materials also conform to NACE MR 0103 for sour refining environments. UltraTherm 805 supports maximum design temperature of 850 °F (454 °C). Design temperature rating is for non-continuous use with a cumulative exposure time less of than 12 hours.

Code	Description
Q15	Certificate of compliance to NACE MR0175/ISO 15156 for wetted materials

Code	Description	
Q25	Certificate of compliance to NACE MR0103 for wetted materials	★

**Positive material identification (PMI)**

Code	Description	
Q76	PMI verification and certificate	★

# Rosemount 3051S Scalable™ Level Transmitter

Rosemount 3051S Scalable Level Transmitters combine the features and benefits of a high-performance Rosemount 3051S with the durability and reliability of diaphragm seals all in a single model number.



Rosemount 3051SAL In-line with “FF” Flanged Seal

Rosemount 3051SAL Coplanar with “SS” Hygienic Tank Spud Seal

Rosemount 3051SAL Tuned-System™ Assembly with Thermal Range Expander

Rosemount 3051SAL Balanced System

Product features and capabilities include:

- Variety of process connections including flanged, threaded, and hygienic seals
- Quantified performance for the entire transmitter/seal assembly (QZ option)
- HART®, FOUNDATION™ Fieldbus, and wireless protocols

[CONFIGURE >](#)

[VIEW PRODUCT >](#)

## Rosemount 3051SAL Scalable Level Transmitter

Specification and selection of product materials, options, or components must be made by the purchaser of the equipment.

A Rosemount 3051SAL Scalable ERS Level Transmitter consists of three parts. First, specify the transmitter model codes found below. Then, specify a direct mount seal found here: [Diaphragm seals for Rosemount 3051SAL](#). Finish the model number by specifying all desired options from the Additional Options section.

## Online product configurator

Many products are configurable online using our Product Configurator. Select the **Configure** button or visit our [website](#) to start. With this tool's built-in logic and continuous validation, you can configure your products more quickly and accurately.

## Specifications and options

See the Specifications and options section for more details on each configuration. Specification and selection of product materials, options, or components must be made by the purchaser of the equipment. See the Material selection section for more information.



## Model codes

Model codes contain the details related to each product. Exact model codes will vary; an example of a typical model code is shown in Figure 6.

Figure 6: Model Code Example

**3051C D 2 X 2 2 M5 B4**

1            2

1. Required model components (choices available on most)
2. Additional options (variety of features and functions that may be added to products)

## Optimizing lead time

The starred offerings (★) represent the most common options and should be selected for best delivery. The non-starred offerings are subject to additional delivery lead time.

## Required model components

### Model

Code	Transmitter type	
3051SAL	Scalable level transmitter	★

### Performance class

Code	Description	
1	Ultra: 0.055% span accuracy, 150:1 rangedown, 15-year limited warranty	★
2	Classic: 0.065% span accuracy, 150:1 rangedown	★

### Configuration type

Code	Description	
C	Liquid level transmitter	★

### Pressure module type

Code	Module type	Sensor type	
D	Coplanar	Differential	★
G	Coplanar	Gauge	★
T	In-line	Gauge	

## Pressure range

Code	Coplanar DP	Coplanar Gauge	In-line Gauge	In-line Absolute	Coplanar Absolute	
1A	N/A	N/A	-14.7 to 30 psig (-1.01 to 2.06 bar)	0 to 30 psia (0 to 2.06 bar)	0 to 30 psia (0 to 2.06 bar)	★
2A	-250 to 250 inH <sub>2</sub> O (-621.60 to 621.60 mbar)	-250 to 250 inH <sub>2</sub> O (-621.60 to 621.60 mbar)	-14.7 to 150 psig (-1.01 to 10.34 bar)	0 to 150 psia (0 to 10.34 bar)	0 to 150 psia (0 to 10.34 bar)	★
3A	-1000 to 1000 inH <sub>2</sub> O (-2.48 to 2.48 bar)	-393 to 1000 inH <sub>2</sub> O (-0.97 to 2.48 bar)	-14.7 to 800 psig (-1.01 to 55.15 bar)	0 to 800 psia (0 to 55.15 bar)	0 to 800 psia (0 to 55.15 bar)	★
4A	-300 to 300 psi (-20.68 to 20.68 bar)	-14.2 to 300 psig (-0.97 to 20.68 bar)	-14.7 to 4000 psig (-1.01 to 275.79 bar)	0 to 4000 psia (0 to 275.79 bar)	0 to 4000 psia (0 to 275.79 bar)	★
5A	-2000 to 2000 psi (-137.89 to 137.89 bar)	-14.2 to 2000 psig (-0.97 to 137.89 bar)	-14.7 to 10000 psig (-1.01 to 689.47 bar)	0 to 10000 psia (0 to 689.47 bar)	N/A	★

## Transmitter output

Code	Description	
A	4–20 mA with digital signal based on HART® protocol	★
F <sup>(1)</sup>	FOUNDATION™ Fieldbus protocol	★
X <sup>(2)</sup>	Wireless (requires wireless options and wireless Plantweb™ housing)	★

(1) Requires Plantweb™ housing.

(2) Only intrinsically safe approval codes apply.

## Housing style

Code	Description	Material	Conduit entry size	
<b>Housings for ERS primary - configuration type code P</b>				
1A	Plantweb™ housing	Aluminum	½–14 NPT	★
1B	Plantweb housing	Aluminum	M20 x 1.5 (CM 20)	★
1J	Plantweb housing	SST	½–14 NPT	★
1K	Plantweb housing	SST	M20 x 1.5 (CM 20)	★
2E	Junction box with remote display output	Aluminum	½–14 NPT	★
2F	Junction box with remote display output	Aluminum	M20 x 1.5 (CM 20)	★
2M	Junction box with remote display output	SST	½–14 NPT	★
1C	Plantweb housing	Aluminum	G½	
1L	Plantweb housing	SST	G½	
2G	Junction box with remote display output	Aluminum	G½	
<b>Housings for ERS secondary - configuration type code S</b>				
2A	Junction box	Aluminum	½–14 NPT	★

Code	Description	Material	Conduit entry size	
<b>Housings for ERS primary - configuration type code P</b>				
2B	Junction box	Aluminum	M20 x 1.5 (CM 20)	★
2J	Junction box	SST	½–14 NPT	★
2C	Junction box	Aluminum	G½	

**Seal system type**

Code	Coplanar pressure module type		In-line pressure module type		
1	Direct mount single seal system	Welded-repairable	Direct mount single seal system	All welded	★
2	Direct mount single seal system	All welded	N/A	N/A	★
3	Tuned-system assembly - one direct mount and one remote mount seal with capillary	Welded-repairable	N/A	N/A	★
4	Tuned-system assembly - one direct mount and one remote mount seal with capillary	All welded	N/A	N/A	★
5	Balanced system - two remote mount seals with equal lengths of capillary	Welded-repairable	N/A	N/A	★
6	Balanced system - two remote mount seals with equal lengths of capillary	All welded	N/A	N/A	★
7	Remote mount single seal system with capillary - 316L low side transmitter isolator	Welded-repairable	Remote mount single seal system with capillary	All welded	★
8	Remote mount single seal system with capillary - 316L low side transmitter isolator	All welded	N/A	N/A	★
9	Remote mount single seal system with capillary - Alloy C-276 low side transmitter isolator	Welded-repairable	N/A	N/A	★
A	Remote mount single seal system with capillary - Alloy C-276 low side transmitter isolator	All welded	N/A	N/A	★

**High side connection type (select based on seal system type chosen)**

Code	Single seal system				Dual seal system		
	Direct mount		Remote mount with capillary		Tuned-system assembly	Balanced system	
	Coplanar	In-line	Coplanar	In-line	Coplanar	Coplanar	
0	No extension		Standard	Standard	No extension/Standard	Standard	★
2	2-in. (50 mm) extension	N/A	N/A	N/A	2-in. (50 mm) extension		★

Code	Single seal system				Dual seal system		
	Direct mount		Remote mount with capillary		Tuned-system assembly	Balanced system	
4	4-in. (100 mm) extension	4-in. (100 mm) extension <sup>(1)</sup>	N/A	N/A	4-in. (100 mm) extension	N/A	★
5	N/A	Thermal optimizer	N/A	N/A	N/A	N/A	★
6 <sup>(2)</sup>	Thermal Range Expander - Silicone 200 secondary fill		Thermal Range Expander - Silicone 200 secondary fill fluid single capillary		Thermal Range Expander - Silicone 200 secondary fill with low side capillary		★
7 <sup>(2)</sup>	Thermal Range Expander - SYLTHERM XLT secondary fill fluid		Thermal Range Expander - SYLTHERM XLT secondary fill fluid single capillary		Thermal Range Expander - SYLTHERM XLT secondary fill with low side capillary		★
8 <sup>(2)</sup>	Thermal Range Expander - Tri-Therm 300 secondary fill fluid		Tri-Therm 300 secondary fill fluid single capillary		Tri-Therm 300 secondary fill fluid with low side capillary		

(1) Maximum working pressure is 4000 psi (275 bar).

(2) Maximum working pressure (MWP) of the Thermal Range Expander is 3750 psi (258.6 bar).

**Low side connection type or capillary I.D.**

Code	Material for low side reference connection		Capillary I.D.			
	Direct mount		Remote mount with capillary	Tuned-system assembly	Balanced system	
	Coplanar	In-line	Coplanar or In-line	Coplanar	Coplanar	
0	N/A	No reference connection	N/A	N/A	N/A	★
1 <sup>(1)(2)</sup>	Assemble to one Rosemount 1199 remote seal	N/A	N/A	N/A	N/A	★
2	316L SST isolator and SST transmitter flange	N/A	N/A	N/A	N/A	★
3	Alloy C-276 isolator and SST transmitter flange	N/A	N/A	N/A	N/A	★
B	N/A	N/A	0.03-in. (0.711 mm) ID capillary	0.03-in. (0.711 mm) ID capillary	0.03-in. (0.711 mm) ID capillary	
C	N/A	N/A	0.04-in. (1.092 mm) ID capillary	0.04-in. (1.092 mm) ID capillary	0.04-in. (1.092 mm) ID capillary	
D	N/A	N/A	0.075-in. (1.905 mm) ID capillary	0.075-in. (1.905 mm) ID capillary	0.075-in. (1.905 mm) ID capillary	

Code	Material for low side reference connection		Capillary I.D.			
			Remote mount with capillary	Tuned-system assembly	Balanced system	
E <sup>(3)</sup>	N/A	N/A	0.03-in. (0.711 mm) ID capillary, PVC coated with closed end	0.03-in. (0.711 mm) ID capillary, PVC coated with closed end	0.03-in. (0.711 mm) ID capillary, PVC coated with closed end	★
F	N/A	N/A	0.04-in. (1.092 mm) ID capillary, PVC coated with closed end	0.04-in. (1.092 mm) ID capillary, PVC coated with closed end	0.04-in. (1.092 mm) ID capillary, PVC coated with closed end	★
G	N/A	N/A	0.075-in. (1.905 mm) ID capillary, PVC coated with closed end	0.075-in. (1.905 mm) ID capillary, PVC coated with closed end	0.075-in. (1.905 mm) ID capillary, PVC coated with closed end	★

- (1) Requires separate Rosemount 1199 model number to be selected. With option code 1, user must select Seal Location Option code M (low side of transmitter) in the Rosemount 1199 Remote Mount Seal System Model.
- (2) Not suitable for vacuum applications.
- (3) PVC coating should not be exposed to temperatures above 212 °F (100 °C) to avoid possibility of thermal breakdown.

### Capillary length





Capillary length applies to both high and low side for balanced systems. Applies to low side only for tuned-system assemblies. Applies to high side only for remote mount single seal systems with capillary.



Code	Description	
0	No capillary (required for direct mount single seal system)	★
A	1 ft. (0.3 m)	★
B	5 ft. (1.5 m)	★
C	10 ft. (3.0 m)	★
D	15 ft. (4.5 m)	★
E	20 ft. (6.1 m)	★
F	25 ft. (7.6 m)	★
G	30 ft. (9.1 m)	★
H	35 ft. (10.7 m)	★
J	40 ft. (12.2 m)	★
K	45 ft. (13.7 m)	★
L	50 ft. (15.2 m)	★
M	1.6 ft. (0.5 m)	★

Code	Description	
N	3.3 ft. (1.0 m)	★
P	4.9 ft. (1.5 m)	★
R	6.6 ft. (2.0 m)	★
T	8.2 ft. (2.5 m)	★
U	9.8 ft. (3.0 m)	★
V	11.5 ft. (3.5 m)	★
W	13.1 ft. (4.0 m)	★
Y	16.4 ft. (5.0 m)	★
Z	19.7 ft. (6.0 m)	★
1	23 ft. (7.0 m)	★
2	26.2 ft. (8.0 m)	★
3	29.5 ft. (9.0 m)	★
4	32.8 ft. (10.0 m)	★
5	36.1 ft. (11.0 m)	★
6	39.4 ft. (12.0 m)	★
7	42.6 ft. (13.0 m)	★
8	45.9 ft. (14.0 m)	★
9	49.2 ft. (15.0 m)	★

### Seal fill fluid

### Seal style

Seal type	Model	Process connection
	Flush Flanged (FF) Seal	2-in./DN 50/50A 3-in./DN 80/80A 4-in./ DN 100/100A
	Extended Flanged (EF) Seal	3-in./DN 80/80A 4-in./DN 100/100A
	Remote Flanged (RF) Seal	½-in. ¾-in. 1-in./DN 25/25A 1½-in./DN 40/40A
	RC Remote Flanged Seal - Ring Type Joint (RTJ) gasket surface	½-in. ¾-in. 1-in. 1½-in.

Seal type	Model	Process connection
	SC Hygienic Tri Clamp Seal	1½-in. 2-in. 3-in.
	SS Hygienic Tan Spud Seal	4-in.

## Wireless options

### Update rate

This is only available with output code X.

Code	Description	
WA	User configurable update rate	★

### Operating frequency and protocol

Code	Description	
3	2.4 GHz DSSS, IEC 62591 ( <i>WirelessHART</i> ®)	★

### Omni-directional wireless antenna

Code	Description	
WK	External antenna	★
WM	Extended range, external antenna	★
WN	High-gain, remote antenna	

### SmartPower

Long-life power module must be shipped separately, order power module 701PBKKF. This is not available with output code A.

Code	Description	
1	Adapter for Black Power Module (I.S. Power Module sold separately)	★

## Additional options

### HART® Revision configuration (requires HART Protocol output code A)

Option HR7 configures the HART output to HART Revision 7. This option requires the selection of the Advanced Diagnostics (DA2) option. The device with this option can be field configured to HART Revision 5 or 7 if desired.

Code	Description	
HR7	Configured for HART Revision 7	★

### Extended product warranty

Code	Description	
WR3	3-year limited warranty	★
WR5	5-year limited warranty	★

### Plantweb control functionality

This is not available with output code A and X. With option code 10, user must select seal location option code M in Rosemount DP Level [Product Data Sheet](#). Requires FOUNDATION™ Fieldbus output code F.

Code	Description	
A01	Foundation Fieldbus advanced control function block suite	★

### Diagnostics suite

Code	Description	
D01 <sup>(1)</sup>	FOUNDATION™ Fieldbus diagnostics suite (Process Intelligence, Plugged Impulse Line diagnostic)	★
DA2 <sup>(2)</sup>	Advanced HART® diagnostics suite (Process Intelligence, Loop Integrity, Plugged Impulse Line diagnostic, Process Alerts, Service Alerts, Variable Log, Event Log)	★

(1) This is not available with output code X and A.

(2) Requires Plantweb housing and output code A. Includes hardware adjustments as standard.

### Mounting bracket

Code	Description	
B4	Bracket, all SST, 2-in. pipe panel	★
BE	Bracket, 316 SST, B4-style with 316 SST bolting	★

### Software configuration

This is not available with output code F.

Code	Description	
C1	Custom software configuration (requires Configuration Data Sheet)	★



### Gauge pressure calibration

Code	Description	
C3	Gauge pressure calibration on Rosemount 3051SAL A4 only	★

### Alarm limit

This is not available with output code F and X.

Code	Description	
C4	NAMUR alarm and saturation levels, high alarm	★
C5	NAMUR alarm and saturation levels, low alarm	★
C6	Custom alarm and saturation signal levels, high alarm (requires C1 and Configuration Data Sheet)	★
C7	Custom alarm and saturation signal levels, low alarm (requires C1 and Configuration Data Sheet)	★
C8	Low alarm (standard Rosemount alarm and saturation levels)	★

### Hardware adjustments

This is not available with output code F, X, and housing style codes 00, 2E, 2F, 2G, 2M, 5A, 5J, or 7J.

Code	Description	
D1	Hardware adjustments (zero, span, alarm, security)	★

### Flange adapter

Code	Description	
D2	½–14 NPT flange adapter	★
D9	RC½ SST flange adapter	

### Ground screw

This assembly is included with options EP, KP, E1, N1, K1, ND, E4, E7, N7, K7, E2, E3, KA, KC, KD, IA, IB, IE, IF, IG, KG, T1, K2, N3, EM, and KM.

Code	Description	
D4	External ground screw assembly	★

### Drain/vent valve

Code	Description	
D5	Delete transmitter drain/vent valves (install plugs)	★

## Conduit plug

Transmitter is shipped with 316 SST conduit plug (uninstalled) in place of standard aluminum conduit plug.

Code	Description	
DO	316 SST conduit plug	★

## Product certifications

Valid when SuperModule Platform and housing have equivalent approvals.

Code	Description	
E1	ATEX Flameproof	★
I1	ATEX Intrinsic Safety	★
IA	ATEX FISCO Intrinsic Safety (FOUNDATION Fieldbus protocol only)	★
N1	ATEX Type n	★
K1	ATEX Flameproof and Intrinsically Safe, Type n, Dust	★
ND	ATEX Dust	★
E4	TIIS Flameproof	★
E5	FM Explosion-proof, Dust Ignition-proof	★
I5	FM Intrinsically Safe, Division 2	★
IE	FM FISCO Intrinsically Safe (FOUNDATION Fieldbus protocol only)	★
K5	FM Explosion-proof, Dust Ignition-proof, Intrinsically Safe, Division 2	★
E6 <sup>(1)</sup>	CSA Explosion-proof, Dust Ignition-proof, Division 2	★
I6	CSA Intrinsically Safe	★
IF	CSA FISCO Intrinsically Safe (FOUNDATION Fieldbus protocol only)	★
K6 <sup>(1)</sup>	CSA Explosion-proof, Dust Ignition-proof, Intrinsically Safe, Division 2	★
D3 <sup>(2)</sup>	Measurement Canada Accuracy Approval	★
E7	IECEX Flameproof	★
I7	IECEX Intrinsic Safety	★
IG	IECEX FISCO Intrinsic Safety (FOUNDATION Fieldbus protocol only)	★
N7	IECEX Type n	★
K7	IECEX Flameproof, Intrinsic Safety, Type n	★
E2	INMETRO Flameproof	★
I2	INMETRO Intrinsically Safe	★
IB	INMETRO FISCO Intrinsic Safety	★
K2	INMETRO Flameproof, Intrinsic Safety, Type n	★
E3	China Flameproof	★
I3	China Intrinsic Safety, Dust Ignition-proof	★
EP	Korea Flameproof	★
IP	Korea Intrinsic Safety	★

Code	Description	
KP	Korea Flameproof, Intrinsic Safety	★
EM	Technical Regulations Customs Union (EAC) Flameproof	★
IM	Technical Regulations Customs Union (EAC) Intrinsic Safety	★
IN	Technical Regulations Customs Union (EAC) FISCO Intrinsic Safety	
KM	Technical Regulations Customs Union (EAC) Flameproof, Intrinsic Safety	★
KA <sup>(1)</sup>	ATEX and CSA Flameproof, Intrinsically Safe, Division 2	★
KB <sup>(1)</sup>	FM and CSA Explosion-proof, Dust Ignition-proof, Intrinsically Safe, Division 2	★
KC	FM and ATEX Explosion-proof, Intrinsically Safe, Division 2	★
KD <sup>(1)</sup>	FM, CSA, and ATEX Explosion-proof, Intrinsically Safe	★

(1) Not available with M20 or G½ conduit entry size.

(2) Requires Plantweb housing and hardware adjustments option code D1. Limited availability depending on transmitter type and range. Contact an Emerson representative for additional information.

## Shipboard approvals

Code	Description	
SBS	American Bureau of Shipping	★
SBV	Bureau Veritas (BV) Type Approval	★
SDN	Det Norske Veritas (DNV) Type Approval	★
SLL	Lloyds Register (LR) Type Approval	★

## Stainless steel tagging

Code	Description	
Y2	316 SST nameplate, top tag, wire-on tag(s), and fasteners	★

## Sensor fill fluid

Silicone fill fluid is standard.

Code	Description	
L1	Inert sensor fill fluid	★

## O-ring

Code	Description	
L2	Graphite-filled PTFE O-ring	★

## Bolting material

Code	Description	
L4	Austenitic 316 SST bolts	★
L5 <sup>(1)</sup>	ASTM A 193, Grade B7M bolts	★
L6	Alloy K-500 bolts	★
L7 <sup>(1)</sup>	ASTM A 453, Class D, Grade 660 bolts	★
L8	ASTM A 193, Class 2, Grade B8M bolts	★

(1) *Materials of construction comply with metallurgical requirements highlighted within NACE MR 0175/ISO 15156 for sour oil field production environments. Environmental limits apply to certain materials. Consult latest standard for details. Selected materials also conform to NACE MR 0103 for sour refining environments. Order with Q15 or Q25 to receive a NACE certificate.*

## Display type

See the Rosemount 3051S [Reference Manual](#) for cable requirements. Contact an Emerson representative for additional information. Not available with output code A and housing code 01 or 7J.

Code	Description	
M5 <sup>(1)</sup>	Plantweb LCD display	★
M7	Remote mount LCD display and interface, Plantweb housing, no cable, SST bracket	★
M8	Remote mount LCD display and interface, Plantweb housing, 50 ft. (15 m) cable, SST bracket	★
M9	Remote mount LCD display and interface, Plantweb housing, 100 ft. (31 m) cable, SST bracket	★

(1) *See the Rosemount 3051S [Reference Manual](#) for cable requirements. Contact an Emerson representative for additional information.*

## Pressure testing

Code	Description	
P1	Hydrostatic testing with certificate	

## Special cleaning

This is not available with process connection code A11.

Code	Description	
P2	Cleaning for special services	
P3	Cleaning for less than 1 PPM Chlorine/Fluorine	

## Calibration certification

Code	Description	
Q4	Calibration certificate	★
QP	Calibration certificate and tamper evident seal	★

### Material traceability certification

Code	Description	
Q8	Material traceability certification per EN 10204 3.1	★

### Quality certification for safety

This option is not available with output code F or X. This option is not available with housing code 7J.

Code	Description	
QT	Safety-certified to IEC 61508 with certificate of FMEDA data	★

### Toolkit performance reports

Code	Description	
QZ	Remote seal system performance calculation report	★

### Transient protection

The T1 option is not needed with FISCO Product Certifications; transient protection is included in the FISCO product certification codes IA, IB, IE, IF, and IG. Not available with Housing code 5A, 5J, or 7J.

Code	Description	
T1	Transient terminal block	★

### Conduit electrical connector

This is not available with Housing code 5A, 5J, or 7J. Available with Intrinsically Safe approvals only. For FM Intrinsically Safe; Nonincendive (option code I5) or FM FISCO Intrinsically Safe (option code IE), install in accordance with Rosemount drawing 03151-1009.

Code	Description	
GE	M12, 4-pin, male connector (eurofast)	★
GM	A size mini, 4-pin, male connector (minifast)	★

### NACE certificate

Materials of construction comply with metallurgical requirements highlighted within NACE® MR 0175/ISO 15156 for sour oil field production environments. Environmental limits apply to certain materials. Consult latest standard for details. Selected materials also conform to NACE MR 0103 for sour refining environments. Order with Q15 or Q25 to receive a NACE certificate.

Code	Description	
Q15	Certificate of compliance to NACE MR0175/ISO 15156 for wetted materials	★
Q25	Certificate of compliance to NACE MR0103 for wetted materials	★

### Positive material identification (PMI)

Code	Description	
Q76	PMI verification and certificate	★

# Diaphragm seals for Rosemount 3051SAL

## Flush Flanged (FF) Seal



- Most common seal
- Good for use in general applications
- Easy installation on flanged connections ranging from 2-in. (DN 50) to 4-in. (DN 100)

Specification and selection of product materials, options, or components must be made by the purchaser of the equipment.

## Required model components

### Model

Code	Description
FF	Flush flanged seal

### Process connection size

Code	ASME B16.5	EN 1092-1/GOST 33259-15	JIS B2238	
G	2-in.	DN 50	50 A	★
7	3-in.	N/A	80 A	★

### Flange/pressure rating

### Materials of construction

Code	Isolating diaphragm	Upper housing	Flange	
CA	316L SST	316L SST	CS	★
DA	316L SST	316L SST	316 SST	★
CB <sup>(1)</sup>	Alloy C-276	316L SST	CS	★
DB <sup>(1)</sup>	Alloy C-276, seam-welded	316L SST	316 SST	★

(1) Not available with option code SC.

**Flushing connection ring (lower housing)**

Code	Description	
0	None	★
A <sup>(1)</sup>	316 SST	★
B <sup>(1)</sup>	Alloy C-276	★

(1) Supplied with Thermo-Tork TN-9000 gasket if no other flushing connection ring gasket option is selected.

**Flushing connection quantity and size**

Code	Description	
0	None	★
1	One ¼–18 NPT flushing connection	★
3	Two ¼–18 NPT flushing connections	★
7	One ½–14 NPT flushing connection	★
9	Two ½–14 NPT flushing connections	★

**Additional options**

**Remote seal diaphragm thickness**

This is not available with Tantalum diaphragms (Material of Construction codes CC and DC).

Code	Description	
SC	0.006-in. (150 µm) available with 316L SST	

**Flushing connection ring plugs**

Code	Description	
SG	SST plug(s) for flushing connection(s)	
SH	SST drain/vent(s) for flushing connection(s)	

**Lower housing alignment clamp**

Code	Description	
SA	Lower housing alignment clamp	★

**Intermediate gasket material**

## Extended Flanged (EF) Seal



- Good for use in viscous applications with plugging issues
- Seal diaphragm installed flush with inner tank wall to prevent process plugging
- Easy installation on 3-in. (DN 80) and 4-in. (DN 100) flanged connections

Specification and selection of product materials, options, or components must be made by the purchaser of the equipment.

### Required model components

#### Model

Code	Description	
EF	Extended flanged seal	★

#### Process connection size

Code	ASME B16.5	EN 1092-1/GOST 33259-15	JIS B2238	Extension diameters	
7	3-in. schedule 80	DN 80	80A	2.58-in. (66 mm)	★

#### Materials of construction

Code	Isolating diaphragm	Extension/gasket surface	Mounting flange	
CA	316L SST	316L SST	CS	★
DA	316L SST	316L SST	316 SST	★
CB	Alloy C-276	Alloy C-276	CS	
DB	Alloy C-276	Alloy C-276	316 SST	

#### Seal extension length

Code	Description	
20	2-in. (50 mm)	★
40	4-in. (100 mm)	★
60 <sup>(1)</sup>	6-in. (150 mm)	

(1) Only available with SST (model code CA & DA)



## Remote Flanged (RF) Seal



- Designed to improve performance on smaller process connections
- Easy installation on flanged connections ranging from ½- to 1½-in. (DN 25– DN 40)
- Lower housing/flushing ring required

Specification and selection of product materials, options, or components must be made by the purchaser of the equipment.

### Required model components

#### Model

Code	Description	
RF	Remote flanged seal	★

#### Process connection size

Code	ASME B16.5	EN 1092-1/GOST 33259-15	JIS B2238	
2	1-in.	N/A	25A	★
4	1½-in.	N/A	40A	★

#### Flange/pressure rating

#### Materials of construction

Code	Isolating diaphragm	Upper housing	Flange	
CA	316L SST	316L SST	CS	★
DA	316L SST	316L SST	316 SST	★
CB	Alloy C-276	316L SST	CS	
DB	Alloy C-276	316L SST	316 SST	

#### Flushing connection ring material (lower housing)

Supplied with C-4401 aramid fiber gasket if no other remote seal gasket material is selected.

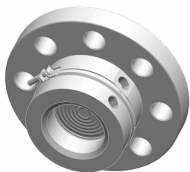
Code	Description	
A	316L SST	★
B	Alloy C-276	★

**Flushing connection quantity and size**

Code	Description	
5	None	★
1	One ¼-18 NPT flushing connection	★
3	Two ¼-18 NPT flushing connections	★
7	One ½-14 NPT flushing connection	
9	Two ½-14 NPT flushing connections	

**Additional options****Flushing connection ring plugs**

Code	Description	
SG	SST plug(s) for flushing connection(s)	
SH	SST drain/vent(s) for flushing connection(s)	

**Flushing ring connection gaskets****PF Pancake Seal**

- Remote mount connection with capillary on the side of the seal
- Support tube used to facilitate installation
- Can be ordered with or without flange

**Required model components****Model**

Code	Description	
PF	Pancake seal	★

**Process connection size**

Code	ASME	EN 1092-1/GOST 33259-15	
G	2-in.	DN 50	★
7	3-in.	N/A	★

Code	ASME	EN 1092-1/GOST 33259-15	
J	N/A	DN 80	★
0	No flanged supplied, seal maximum working pressure (MWP) based on customer supplied flange	N/A	★
9	N/A	No flanged supplied, seal MWP based on customer supplied flange	★
1	Class 150	N/A	★
2	Class 300	N/A	★
4	Class 600	N/A	★
G	N/A	PN40	★
5	Class 900	N/A	
6	Class 1500	N/A	
7	Class 2500	N/A	
H	N/A	PN63	
J	N/A	PN100	

**Materials of construction**

Code	Isolating diaphragm	Upper housing	Flange	
LA <sup>(1)</sup>	316L SST	316L SST	None	★
CA <sup>(1)</sup>	316L SST	316L SST	CS	★
DA <sup>(1)</sup>	316L SST	316L SST	316 SST	★
LB	Alloy C-276, seam-welded	316L SST	None	★
CB	Alloy C-276, seam-welded	316L SST	CS	★
DB	Alloy C-276, seam-welded	316L SST	316 SST	★
LC	Tantalum, seam-welded	316L SST	None	★
CC	Tantalum, seam-welded	316L SST	CS	★
DC	Tantalum, seam-welded	316L SST	316 SST	★
L6	Duplex 2205 SST	316 SST	None	
C6	Duplex 2205 SST	316 SST	CS	
D6	Duplex 2205 SST	316 SST	316 SST	

(1) For use with customer supplied spiral metallic gaskets.

**Flushing connection ring (lower housing)**

Code	Description	
0	None	★
A <sup>(1)</sup>	316 SST	★
B <sup>(1)</sup>	Alloy C-276	★

(1) Supplied with Thermo-Tork TN-9000 gasket if no other flushing connection ring gasket option is selected.

**Flushing connection quantity and size**

Code	Description	
0	None	★
1	One ¼–18 NPT flushing connection	★
3	Two ¼–18 NPT flushing connections	★
7	One ½–14 NPT flushing connection	★
9	Two ½–14 NPT flushing connections	★

**Additional options****Lower housing alignment clamp**

Code	Description	
SA	Lower housing alignment clamp	★

**Flushing connection ring gaskets**

Supplied with Thermo-Tork TN-9000 gasket if no other flushing connection ring gasket option is selected.

Code	Description	
S0	No gasket for lower housing	★
SY	Thermo-Tork TN-9000	★
SJ	PTFE gasket	★
SK	Barium sulfate-filled PTFE gasket	
SN	GRAFOIL gasket	

**Flushing connection ring plugs**

Code	Description	
SG	SST plug(s) for flushing connection(s)	
SH	SST drain/vent(s) for flushing connection(s)	

**Remote seal diaphragm thickness**

This is not available with Tantalum diaphragms (Material of Construction codes CC and DC).

Code	Description	
SC	0.006-in. (150 µm) diaphragm thickness	

**Cold temperature remote seal applications**

Code	Description	
RB	Extra fill fluid for cold temperature applications	

**Remote seal diaphragm coating**

Code	Description
SZ <sup>(1)</sup>	0.0002-in. (5 μm) gold-plated diaphragm
SV	PTFE coated diaphragm for non-stick purposes
FG	PermeationShield™ 0.0002-in. (5μm) inner gold-plated diaphragm

(1) Not available with Tantalum diaphragms (Material of Construction codes CC and DC).

**Complete the 3051SAL model number by specifying options as needed:**

ERS Transmitter options found at [Rosemount 3051SAL Transmitter for ERS Applications](#)

Scalable level transmitter options found at [Rosemount 3051S Scalable™ Level Transmitter](#)

**FC Flush Flanged Seal - Ring Type Joint (RTJ) gasket surface**



- RTJ gaskets are metallic sealing rings, often used in high pressure/high temperature applications
- Gasket surface on seal contains groove for RTJ gasket (user supplied)

**Required model components**

**Model**

Code	Description
FC	Flush flanged seal - Ring Type Joint (RTJ) gasket surface

**Process connection size**

Code	Description
G	2-in.
7	3-in.
9	4-in.

**Flange/pressure rating**

Code	Description
1	Class 150
2	Class 300
4	Class 600

Code	Description
5	Class 900
6	Class 1500
7	Class 2500

#### Materials of construction

Code	Diaphragm and wetted	Upper housing	Flange
DA	316L SST	316L SST	316 SST
KB	Alloy C-276	316L SST	316 SST
K6	Duplex 2205 SST	316 SST	316 SST
MB	Alloy C-276	316L SST	CS
CA	316L SST	316L SST	CS
M6	Duplex 2205 SST	316 SST	CS

#### Flushing connection ring material (lower housing)

Code	Description
0	None
A	316 SST
B	Alloy C-276

#### Flushing connection quantity and size

Code	Description
0	None
1	One ¼–18 NPT flushing connection
3	Two ¼–18 NPT flushing connections
7	One ½–14 NPT flushing connection
9	Two ½–14 NPT flushing connections

#### Additional options

##### Flushing ring connection plugs

Code	Description
SF	Alloy C-276 plug(s) for flushing connection(s)
SG	SST plug(s) for flushing connection(s)
SH	SST drain/vent(s) for flushing connection(s)

**Remote seal diaphragm thickness**

This is not available with Tantalum diaphragms (Material of Construction codes CC and DC).

Code	Description
SC	0.006-in. (150 μm) available with 316L SST

**Cold temperature remote seal applications**

Code	Description
RB	Extra fill fluid for cold temperature applications

**Remote seal diaphragm coating**

This is only available on 316LSST and Alloy C-276.

Code	Description
SZ	0.002-in. (5 μm) gold-plated diaphragm
SV	PTFE coated diaphragm for nonstick purposes only
FG	PermeationShield™ 0.0002-in. (5μm) inner gold-plated diaphragm

**Complete the 3051SAL model number by specifying options as needed:**

ERS Transmitter options found at [Rosemount 3051SAL Transmitter for ERS Applications](#)

Scalable level transmitter options found at [Rosemount 3051S Scalable™ Level Transmitter](#)

**RC Remote Flanged Seal - Ring Type Joint (RTJ) gasket surface**



- Remote mounted with capillary
- RTJ gaskets are metallic sealing rings, often used in high pressure/high temperature applications
- Gasket surface on seal contains groove for RTJ gasket (user supplied)

**Required model components**

**Model**

Code	Description
RC	Remote flanged seal - Ring Type Joint (RTJ) gasket surface

**Process connection sizes**

Code	Description
1	½-in. (Class 150 to 1500 includes mounting ring bolts and mounting studs)
A	¾-in. (Class 150 includes mounting ring bolts and mounting studs)
2	1-in.
4	1½-in.

**Flange/pressure rating**

Code	Description
1	Class 150
2	Class 300
4	Class 600
5	Class 900
6	Class 1500
7	Class 2500

**Materials of construction**

Code	Diaphragm and wetted	Upper housing
LA	316L SST	316L SST
LB	Alloy C-276	316L SST
LC	Tantalum	316L SST

**Flushing connection ring material (lower housing)**

Supplied with C-4401 aramid fiber gasket if no other remote seal gasket material is selected.

Code	Description
A	316L SST
B	Alloy C-276

**Flushing ring connection and size**

Code	Description
0	None
1	One ¼–18 NPT flushing connection
3	Two ¼–18 NPT flushing connections
7	One ½–14 NPT flushing connection
9	Two ½–14 NPT flushing connections



## Additional options

### Flushing ring connection gaskets

### Flushing connection ring plugs

Code	Description
SF	Alloy C-276 plug(s) for flushing connection(s)
SG	316 SST plug(s) for flushing connection(s)
SH	316 SST vent/drain for flushing connection(s)

### Remote seal diaphragm thickness

Code	Description
SC	0.006-in. (150 μm) available with 316L SST, Alloy C-276, and Duplex 2205 SST for abrasive applications

### Remote seal bolt material

Code	Description
S3 <sup>(1)</sup>	304 SST bolts (only available for stud bolt design)
S4	316 SST bolts (only available for stud bolt design) ★

(1) Standard stud bolts are carbon steel.

### Large diaphragm size

Code	Description
S9	4.1-in. (104 mm) diaphragm diameter

### Cold temperature remote seal applications

Code	Description
RB	Extra fill fluid for cold temperature applications

### Remote seal diaphragm coating

This is only available on 316LSST and Alloy C-276.

Code	Description
SZ	0.002-in. (5 μm) gold-plated diaphragm
SV	PTFE coated diaphragm for nonstick purposes only
FG	PermeationShield™ 0.0002-in. (5μm) inner gold-plated diaphragm

### Complete the 3051SAL model number by specifying options as needed:

ERS Transmitter options found at [Rosemount 3051SAL Transmitter for ERS Applications](#)

Scalable level transmitter options found at [Rosemount 3051S Scalable™ Level Transmitter](#)

## Remote Threaded (RT) Seal



- For use with threaded process connections (¼-18 to 1-11.5 NPT)
- Rated for use in high-pressure applications (up to 2500 PSI)
- Optional flushing connections available

### Required model components

#### Model

Code	Description	
RT	Remote threaded seal	★

#### Process connection size

#### Pressure rating

Code	Description	
0	2500 psi	★

#### Isolating diaphragm material

Code	Description	Upper housing material	Flange	
CA	316L SST	316L SST	CS	★
DA	316L SST	316L SST	316 SST	★
CB	Alloy C-276	316L SST	CS	
DB	Alloy C-276	316L SST	316 SST	

#### Flushing connection ring material (lower housing)

Supplied with C4401 aramid fiber gasket if no other remote seal gasket material is selected. Flushing connection ring/lower housing assembly bolts provided as standard are carbon steel.

Code	Description	
A	316L SST	★

**Flushing ring connection quantity and size**

Code	Description
1	One ¼-in. flushing connection
3	Two ¼-in. flushing connections
5	None
7	One ½-14 NPT flushing connection
9	Two ½-14 NPT flushing connection

**Additional options**

**Remote seal flushing plug, drain/vent**

Code	Description
SG	316 SST plug(s) for flushing connection(s)
SH	316 SST drain/vent(s) for flushing connection(s)

**SC Hygienic Tri-Clamp® Seal**



- Good for use in hygienic applications
- Easy installation on Tri-Clover style Tri-Clamp connections (1.5-in. to 3-in.)
- Conforms to 3-A® standard 74-06

**Required model components**

**Model**

Code	Description
SC <sup>(1)(2)</sup>	Tri-Clover style Tri Clamp® seal ★

(1) Clamp and gasket furnished by user. The maximum working pressure is dependent upon the clamp pressure rating.  
 (2) All process wetted parts have surface finish of Ra < 32 µin (0.81 µm) standard unless otherwise specified.

**Process connection size**

Code	Description
5 <sup>(1)</sup>	2-in. ★
7	3-in. ★

(1) Min span is 150 inH<sub>2</sub>O or 373 mbar for 2-in. Tri-Clamp seal.

**Materials of construction**

Code	Isolating diaphragm material	Upper housing material	
LA00	316L SST	316L SST	★
LB00	Alloy C-276	316L SST	

**SS Hygienic Tank Spud Seal**

- Commonly used in hygienic level applications
- Seal diaphragm installed flush with inner tank wall
- Conforms to 3-A standard 74-06

**Required model components****Model**

Code	Description	
SS <sup>(1)(2)</sup>	Hygienic Tank Spud Seal	★

(1) Clamp and ethylene propylene O-ring (conforms to 3-A standard 74 and USP Class VI) supplied.

(2) All process wetted parts have surface finish of  $Ra < 32 \mu\text{in}$  ( $0.81 \mu\text{m}$ ) standard unless otherwise specified.

**Process connection size**

Code	Description	
A	4-in. Sch. 5 Tri-Clamp	★

**Maximum working pressure (clamp rating)**

Code	Description	
0	150 psi (10.3 bar)	★

**Upper housing**

Code	Description	
A	316L SST	★

**Materials of construction**

Code	Diaphragm and wetted	Extension	
AL <sup>(1)</sup>	316L SST	316L SST	★

(1) Diaphragm brazed and TIG-welded to extension.

**Extension length**

Code	Description	
2	2-in. (50 mm) extension	★

**Additional options****Tank spud included with shipment**

Code	Description	
S1	SST Tank spud included with shipment	★

# Specifications

## Performance specifications

### Conformance to specification ( $\pm 3\sigma$ [Sigma])

Technology leadership, advanced manufacturing techniques, and statistical process control ensure pressure measurement specification conformance to  $\pm 3\sigma$  or better.

### Reference accuracy

Stated reference accuracy equations include terminal based linearity, hysteresis, and repeatability. For FOUNDATION™ Fieldbus and wireless devices, use calibrated range in place of span.

**Table 1: Transmitter with Coplanar Sensor Module (Single Variable)**

For Rosemount 3051S assembled to Rosemount 1199 Remote Seals, use 3051SAL specifications.

<b>Differential pressure (3051S_CD, 3051SMV__ 3 or 4)</b>			
<b>Gauge pressure (3051S_CG, 3051SAM__G<sup>(1)</sup>)</b>			
	<b>Ultra</b>	<b>Classic</b>	<b>Ultra for flow<sup>(2)</sup></b>
Ranges 2–4	$\pm 0.025\%$ of span; For spans less than 10:1, $\pm(0.005 + 0.0035[\text{URL}/\text{Span}])\%$ of span	$\pm 0.035\%$ of span; For spans less than 10:1, $\pm(0.015 + 0.005[\text{URL}/\text{Span}])\%$ of span	$\pm 0.04\%$ of reading up to 8:1 DP turndown from URL; $\pm(0.04 + 0.0023[\text{URL}/\text{Reading}])\%$ of reading to 200:1 DP turndown from URL
Range 5	$\pm 0.05\%$ of span; For spans less than 10:1, $\pm(0.005 + 0.0045[\text{URL}/\text{Span}])\%$ of span	$\pm 0.065\%$ of span; For spans less than 10:1, $\pm(0.015 + 0.005[\text{URL}/\text{Span}])\%$ of span	N/A
Range 1	$\pm 0.09\%$ of span; For spans less than 15:1, $\pm(0.015 + 0.005[\text{URL}/\text{Span}])\%$ of span	$\pm 0.10\%$ of span; For spans less than 15:1, $\pm(0.025 + 0.005[\text{URL}/\text{Span}])\%$ of span	N/A
Range 0	$\pm 0.09\%$ of span; For spans less than 2:1, $\pm 0.045\%$ of URL	$\pm 0.10\%$ of span; For spans less than 2:1, $\pm 0.05\%$ of URL	N/A
<b>Absolute pressure (3051S_CA, 3051SAM__A<sup>(1)</sup>)</b>			
	<b>Ultra</b>	<b>Classic</b>	
Ranges 1–4	$\pm 0.025\%$ of span; For spans less than 10:1, $\pm(0.004[\text{URL}/\text{Span}])\%$ of span	$\pm 0.035\%$ of span; For spans less than 10:1, $\pm(0.0065[\text{URL}/\text{Span}])\%$ of span	
Range 0	$\pm 0.075\%$ of span; For spans less than 5:1, $\pm(0.025 + 0.01[\text{URL}/\text{Span}])\%$ of span	$\pm 0.075\%$ of span; For spans less than 5:1, $\pm(0.025 + 0.01[\text{URL}/\text{Span}])\%$ of span	

(1) Specifications are for each gauge/absolute pressure sensor of the Electronic Remote Sensor (ERS)™ System and are not reflective of the DP calculation.

(2) Ultra for Flow is only available for Rosemount 3051S\_CD ranges 2-3. For calibrated spans from 1:1 to 2:1 of URL, add  $\pm 0.005$  percent of span analog output error.

**Table 2: Transmitter with In-Line Sensor Module**

For Rosemount 3051S assembled to Rosemount 1199 Remote Seals, use 3051SAL specifications.

Absolute pressure (3051S_TA, 3051SAM__E <sup>(1)</sup> ) Gauge pressure (3051S_TG, 3051SAM__T <sup>(1)</sup> )		
	Ultra	Classic
Ranges 1–4	±0.025% of span For spans less than 10:1, ±(0.004[URL/Span])% of span	±0.035% of span For spans less than 10:1, ±(0.0065[URL/Span])% of span
Range 5	±0.04% of span For spans less than 10:1 ±0.004% of URL	±0.065% of span For spans less than 10:1 ±0.0065% of URL

(1) Specifications are for each gauge/absolute pressure sensor of the ERS system and are not reflective of the DP calculation.

**Table 3: Transmitter with Multivariable Sensor Module**

For Rosemount 3051S assembled to Rosemount 1199 Remote Seals, use 3051SAL specifications.

Differential pressure and Static pressure (3051SMV__1 or 2)		
	Classic MV	Ultra for flow <sup>(1)</sup>
DP Ranges 2–3	±0.04% of span For spans less than 10:1, ±(0.01 + 0.004[URL/ Span])% of span	±0.04% of reading up to 8:1 DP turndown from URL ±(0.04 + 0.0023[URL/Reading])% of reading to 200:1 DP turndown from URL
DP Range 4	±0.055% of span For spans less than 10:1, ±(0.015 + 0.005[URL/ Span])% of span	±0.05% of reading up to 3:1 DP turndown from URL ±(0.05 + 0.0145[URL/RDC])% of reading to 100:1 DP turndown from URL
DP Range 5	±0.065% of span For spans less than 10:1, ±(0.015 + 0.005[URL/ Span])% of span	N/A
DP Range 1	±0.10% of span For spans less than 15:1, ±(0.025 + 0.005[URL/ Span])% of span	N/A
AP and GP Ranges 3–5 <sup>(2)(3)</sup>	±0.055% of span For spans less than 10:1, ±(0.0065[URL/Span])% of span	±0.025% of span For spans less than 10:1, ±(0.004[URL/Span])% of span

(1) Ultra for Flow is only available for Rosemount 3051SMV DP ranges 2-4. For calibrated DP spans from 1:1 to 2:1 of URL, add ±0.005 percent of span analog output error with transmitter output code A.

(2) For DP range 1, 4 or 5, Classic MV and Ultra for Flow static pressure accuracy is ±0.055 percent of span on SP Range 4 only. For spans less than 5:1, ±(0.013[URL/Span]) percent of span.

(3) For DP range 4 Classic MV and Ultra for Flow static pressure accuracy is ±0.055 percent of span on SP Range 5 only. For spans less than 5:1 ±(0.013[URL/Span]) percent of span.

**Table 4: Liquid Level Transmitter**

Rosemount 3051SAL		
	Ultra	Classic
Ranges 2–5	±0.055% of span For spans less than 10:1, ±(0.015 + 0.005[URL/Span])% of span	±0.065% of span For spans less than 10:1, ±(0.015 + 0.005[URL/Span])% of span

**Table 5: DP Reference Accuracy of Rosemount 3051S ERS System**

Reference Accuracy specifications for ERS system assume that the configuration contains two transmitters with identical sensor ranges, each transmitter sensor is calibrated 0 – URL, and the DP Span = 10 percent of transmitter URL.

<b>Two coplanar gauge transmitters (3051SAM__G)</b>		
	<b>Ultra</b>	<b>Classic</b>
Ranges 2–4	±0.035% of DP span	±0.049% of DP span
Range 5	±0.071% of DP span	±0.092% of DP span
<b>Two coplanar absolute transmitters (3051SAM__A)</b>		
	<b>Ultra</b>	<b>Classic</b>
Ranges 1–4	±0.035% of DP span	±0.049% of DP span
<b>Two in-line gauge transmitters (3051SAM__T)</b>		
	<b>Ultra</b>	<b>Classic</b>
Ranges 1–4	±0.035% of DP span	±0.049% of DP span
<b>Two liquid level transmitters (3051SAL)</b>		
	<b>Ultra</b>	<b>Classic</b>
Ranges 1–5	±0.092% of DP span	±0.092% of DP span

**Process temperature RTD interface**

Specifications for process temperature are for the transmitter portion only. The transmitter is compatible with any Pt 100 (100 ohm platinum) RTD. Examples of compatible RTDs include Rosemount 214C RTD Temperature Sensors.

<b>Process temperature (3051SMV__1 or 3)</b>
±0.67 °F (0.37 °C)

**DP total accuracy for Enhanced ERS System performance**

Includes full ambient and temperature range from –40 to 85 °C (–40 to 185 °F) requires two transmitters with identical sensor ranges. Specification are only applicable for spans down to 10:1.

<b>Sensor type</b>	<b>3051SAM__G2, 3051SAL__G2 250 inH<sub>2</sub>O (622.1 mbar)</b>	<b>3051SAM__G3, 3051SAL__G3 1000 inH<sub>2</sub>O (2488.4 mbar)</b>	<b>3051SAM__T1, 3051SAL__T1 30 psi (2.1 bar)</b>	<b>3051SAM__T2, 3051SAL__T2 150 psi (10.34 bar)</b>	<b>3051SAM__G4, 3051SAL__G4 300 psi (20.7 bar)</b>	<b>3051SAM__T3, 3051SAL__T3 800 psi (55.2 bar)</b>
Rosemount 3051SAM <sup>(1)</sup>	0.2 inH <sub>2</sub> O (0.5 mbar)	0.6 inH <sub>2</sub> O (1.4 mbar)	0.9 inH <sub>2</sub> O (2.2 mbar)	1.5 inH <sub>2</sub> O (4.0 mbar)	6.2 inH <sub>2</sub> O (15 mbar)	7.8 inH <sub>2</sub> O (19 mbar)
Rosemount 3051SAL with direct mount seal types and sizes below <sup>(2)</sup> : <ul style="list-style-type: none"> <li>■ FF, FC, PF ≥ 2-in./DN50</li> <li>■ EF ≥ 3-in./DN80</li> <li>■ All RT, RF, RC, SS</li> <li>■ SC ≥ 2.5-in.</li> </ul>	2.2 inH <sub>2</sub> O (5.5 mbar)	2.3 inH <sub>2</sub> O (5.8 mbar)	3.0 inH <sub>2</sub> O (7.5 mbar)	3.2 inH <sub>2</sub> O (8.0 mbar)	6.5 inH <sub>2</sub> O (16 mbar)	8.3 inH <sub>2</sub> O (21 mbar)



Sensor type	3051SAM_ _G2, 3051SAL_ _G2 250 inH <sub>2</sub> O (622.1 mbar)	3051SAM_ _G3, 3051SAL_ _G3 1000 inH <sub>2</sub> O (2488.4 mbar)	3051SAM_ _T1, 3051SAL_ _T1 30 psi (2.1 bar)	3051SAM_ _T2, 3051SAL_ _T2 150 psi (10.34 bar)	3051SAM_ _G4, 3051SAL_ _G4 300 psi (20.7 bar)	3051SAM_ _T3, 3051SAL_ _T3 800 psi (55.2 bar)
Rosemount 3051SAL with other seal types and sizes	Consult Instrument Toolkit™ for performance.					

- (1) For Rosemount 3051SAM assembled to a Rosemount 1199 Diaphragm Seal, use Rosemount 3051SAL specification for identical seal types and sizes.
- (2) For Rosemount 3051SAL with direct mount seals, specification applies to process temperatures from -45 to 205 °C and excludes diaphragm option code SC, 6-mil diaphragm thickness. Seal types outside these parameters will require a Toolkit calculation for performance.

### Transmitter total performance

Total performance is based on combined errors of reference accuracy, ambient temperature effect, and line pressure effect at normal operating conditions (70 percent of span typical reading, 740 psi [51 bar] line pressure). For performance of ranges not listed please contact the factory.

Models	Ultra	Classic and classic MV	Ultra for flow <sup>(1)</sup>
3051S_CD	Ranges 2–3	±0.14% of span  For ±50 °F (28 °C) temperature changes, 0–100% relative humidity, from 1:1 to 5:1 rangedown	±0.15% of reading  For ±50 °F (28 °C) temperature changes, 0-100% relative humidity, over 8:1 DP turndown from URL
3051S_CG	Ranges 2–5		
3051S_CA	Ranges 2–4		
3051S_T	Ranges 2–4		
3051SMV <sup>(2)</sup> (3)	DP Ranges 2–3		
3051SAM_ _G <sup>(4)</sup>	Ranges 2–5		
3051SAM_ _A <sup>(4)</sup>	Ranges 2–4		
3051SAM_ _T <sup>(4)</sup>	Ranges 2–4		
3051SAM_ _E <sup>(4)</sup>	Ranges 2–4		
3051SAL	Use Instrument Toolkit or the QZ Option to quantify the total performance of a remote seal assembly under operating conditions.		

- (1) Ultra for Flow is only available for 3051S\_CD Ranges 2–3 and 3051SMV DP Ranges 2–4.
- (2) For Rosemount 3051SMV, Transmitter Total Performance specification applies to differential pressure measurement only.
- (3) Only applicable with static pressure range 3 and 4.
- (4) Specifications are for each gauge/absolute pressure sensor of the ERS system and are not reflective of the DP calculation.

### Multivariable flow performance

#### Note

Flow performance specifications assume device is configured for full compensation of static pressure, process temperature, density, viscosity, gas expansion, discharge coefficient, and thermal correction variances over the specified process operating range using multivariable type M or flow meter measurement types 1 through 4.

Mass, Energy, Actual Volumetric, and Totalized Flow Reference Accuracy <sup>(1)</sup>		
Models	Ultra for flow	Classic MV <sup>(2)</sup>
<b>3051SMV<sup>(3)</sup></b>		
DP Ranges 2–3 <sup>(4)</sup>	±0.65% of flow rate over a 14:1 flow range (200:1 DP range)	±0.70% of flow rate over 8:1 flow range (64:1 DP range)

Mass, Energy, Actual Volumetric, and Totalized Flow Reference Accuracy <sup>(1)</sup>		
Models	Ultra for flow	Classic MV <sup>(2)</sup>
DP Range 1	N/A	±0.90% of flow rate over 8:1 flow range (64:1 DP range)
<b>Annubar flow meter (3051SFA)</b>		
Ranges 2–3	±0.80% of flow rate at 14:1 flow turndown	±1.15% of flow rate at 8:1 flow turndown
<b>Compact Annubar flow meter (3051SFC_A)</b>		
Ranges 2–3		
Standard	±1.55% of flow rate at 14:1 flow turndown	±1.60% of flow rate at 8:1 flow turndown
Calibrated	±0.80% of flow rate at 14:1 flow turndown	±1.00% of flow rate at 8:1 flow turndown
<b>Compact Conditioning Orifice flow meter (3051SFC_C)</b>		
Ranges 2–3		
$\beta = 0.4$	±0.75% of flow rate at 14:1 flow turndown	±1.10% of flow rate at 8:1 flow turndown
$\beta = 0.50, 0.65$	±1.15% of flow rate at 14:1 flow turndown	±1.45% of flow rate at 8:1 flow turndown
<b>Compact Orifice flow meter(3051SFC_P)<sup>(5)</sup></b>		
Ranges 2-3		
$\beta = 0.4$	±1.30% of flow rate at 14:1 flow turndown	±1.45% of flow rate at 8:1 flow turndown
$\beta = 0.50, 0.65$	±1.30% of flow rate at 14:1 flow turndown	±1.45% of flow rate at 8:1 flow turndown
<b>Integral Orifice flow meter (3051SFP)</b>		
Ranges 2–3		
Bore < 0.160	±2.55% of flow rate at 14:1 flow turndown	±2.65% of flow rate at 8:1 flow turndown
0.160 ≤ Bore < 0.500	±1.55% of flow rate at 14:1 flow turndown	±1.70% of flow rate at 8:1 flow turndown
0.500 ≤ Bore ≤ 1.000	±1.05% of flow rate at 14:1 flow turndown	±1.25% of flow rate at 8:1 flow turndown
1.000 < Bore	±1.55% of flow rate at 14:1 flow turndown	±1.70% of flow rate at 8:1 flow turndown

- (1) Energy, actual volumetric, and totalized flow not available with transmitter output code F.
- (2) Differential pressure calibrated at up to 1/10th full scale for optimum flow accuracy/rangeability.
- (3) Uncalibrated differential producer (0.2 < beta < 0.6 Orifice) installed per ASME MFC 3M or ISO 5167-1. Uncertainties for discharge coefficient, producer bore, tube diameter, and gas expansion factor as defined in ASME MFC 3M or ISO 5167-1. Reference accuracy does not include RTD sensor accuracy.
- (4) Only applies to static pressure range 3 and 4. For static pressure range 5, contact the factory.
- (5) For line sizes less than 2-in. (50mm) or greater than 8-in. (200 mm), see the Rosemount DP Flow Meters and Primary Elements [Product Data Sheet](#).

## Uncompensated flow performance

### Note

For measurement types 5–7, refer to the reference accuracy specification for the Rosemount 3051SMV with measurement type P.

### Note

These flow measurement accuracies assume a constant density, viscosity, and expansibility factor.

### Note

Range 1 flow meters experience an additional uncertainty up to 0.9%. Consult your Emerson representative for exact specifications.

Flow performance specifications assume the device only uses DP readings without pressure and temperature compensation.

Models	Ultra	Classic	Ultra for flow
<b>Annubar flow meter (3051SFA)</b>			
Ranges 2–3	±0.95% of flow rate at 8:1 flow turndown	±1.25% of flow rate at 8:1 flow turndown	±0.80% of flow rate at 14:1 flow turndown
<b>Compact annubar flow meter (3051SFC_A)</b>			
Ranges 2–3			
Standard	±1.65% of flow rate at 8:1 flow turndown	±1.70% of flow rate at 8:1 flow turndown	±1.55% of flow rate at 14:1 flow turndown
Calibrated	±0.95% of flow rate at 8:1 flow turndown	±1.25% of flow rate at 8:1 flow turndown	±0.80% of flow rate at 14:1 flow turndown
<b>Compact conditioning orifice flow meter (3051SFC_C)</b>			
Ranges 2–3			
$\beta = 0.4$	±0.90% of flow rate at 8:1 flow turndown	±1.10% of flow rate at 8:1 flow turndown	±0.75% of flow rate at 14:1 flow turndown
$\beta = 0.50, 0.65$	±1.25% of flow rate at 8:1 flow turndown	±1.40% of flow rate at 8:1 flow turndown	±1.15% of flow rate at 14:1 flow turndown
<b>Compact orifice flow meter(3051SFC_P)<sup>(1)</sup></b>			
Ranges 2–3	±1.35% of flow rate at 8:1 flow turndown	±1.80% of flow rate at 8:1 flow turndown	±1.30% of flow rate at 14:1 flow turndown
<b>Integral orifice flow meter (3051SFP)</b>			
Ranges 2–3			
Bore < 0.160	±2.65% of flow rate at 8:1 flow turndown	±2.70% of flow rate at 8:1 flow turndown	±2.60% of flow rate at 14:1 flow turndown
0.160 ≤ Bore < 0.500	±1.70% of flow rate at 8:1 flow turndown	±1.80% of flow rate at 8:1 flow turndown	±1.60% of flow rate at 14:1 flow turndown
0.500 ≤ Bore ≤ 1.000	±1.25% of flow rate at 8:1 flow turndown	±1.35% of flow rate at 8:1 flow turndown	±1.15% of flow rate at 14:1 flow turndown
1.000 < Bore	±1.70% of flow rate at 8:1 flow turndown	±1.80% of flow rate at 8:1 flow turndown	±1.60% of flow rate at 14:1 flow turndown

(1) For line sizes less than 2-in. (50 mm) or greater than 8-in. (200 mm) add an additional 5% uncertainty.

### Long term stability

Table 6: Pressure

Models		Ultra, Enhanced, and Ultra for flow <sup>(1)</sup>	Classic and Classic MV
3051S_CD	Ranges 2–5	±0.15% of URL for 15 years; for ±50 °F (28 °C) temperature changes, up to 1000 psi (68.95 bar) line pressure	±0.20% of URL for 15 years; for ±50 °F (28 °C) temperature changes, up to 1000 psi (68.95 bar) line pressure
3051S_CG	Ranges 2–5		
3051S_CA	Ranges 1–4		
3051S_T	Ranges 1–5		
3051SAM_G <sup>(2)</sup>	Ranges 2–5		
3051SAM_A <sup>(2)</sup>	Ranges 1–4		

**Table 6: Pressure (continued)**

Models		Ultra, Enhanced, and Ultra for flow <sup>(1)</sup>	Classic and Classic MV
3051SAM__T <sup>(2)</sup>	Ranges 1–5		
3051SAM__E <sup>(2)</sup>	Ranges 1–5		
3051SMV__3,4	Ranges 2–5		
3051SF__D,3,4	Ranges 2–5		
3051SMV__1,2	DP Ranges 2–5	±0.15% of URL for 15 years; for ±50 °F (28 °C) temperature changes, up to 1000 psi (68.95 bar) line pressure	±0.20% of URL for 15 years; for ±50 °F (28 °C) temperature changes, up to 1000 psi (68.95 bar) line pressure
3051SF_1,2	AP and GP Ranges 3–4		

(1) *Ultra is only available for Rosemount 3051S, 3051SMV\_\_3 and 4, 3051SF\_3, 4, 7, and D. Ultra for Flow is only available on 3051S\_CD ranges 2–3, 3051SMV DP ranges 2–4, and 3051SF DP ranges 2–3.*

(2) *Specifications are for each gauge/absolute pressure sensor of the ERS system and are not reflective of the DP calculation.*

**Table 7: Process Temperature**

Specifications for process temperature are for the transmitter portion only. The transmitter is compatible with any Pt 100 (100 ohm platinum) RTD. Examples of compatible RTDs include the Rosemount Series 214C RTD Temperature Sensors.

Models		
3051SMV 3051SF	RTD Interface	The greater of ±0.185 °F (0.103 °C) or 0.1% of reading per 5 years (excludes RTD sensor stability).

## Warranty

### Note

Warranty details can be found in Emerson Terms and Conditions of Sale, Document 63445, Rev G (10/06).

Models	Ultra, Enhanced, and Ultra for flow <sup>(1)</sup>	Classic and Classic MV <sup>(2)</sup>	Optional extended warranty <sup>(3)</sup>
All Rosemount 3051S Products	15-year limited warranty	1-year limited warranty	WR3: 3-year limited warranty WR5: 5-year limited warranty

(1) *Rosemount Ultra and Ultra for Flow transmitters have a limited warranty of 15 years from date of shipment. All other provisions of Emerson standard limited warranty remain the same.*

(2) *Goods are warranted for 12 months from the date of initial installation or 18 months from the date of shipment by seller, whichever period expires first.*

(3) *Rosemount extended warranties have a limited warranty of three or five years from date of shipment.*

## Dynamic performance

**Table 8: Total Time Response at 75 °F (24 °C), Includes Dead Time**

For FOUNDATION™ Fieldbus (output code F), add 52 ms to stated values (not including segment macro-cycle). For option code DA2, add 45 ms (nominal) to stated values.

Consult Instrument Toolkit™ for transmitter configurations with remote seals including Rosemount 3051SAL.

3051S_C 3051SF_D	3051S_T	3051SMV__1 or 2 3051SF_1, 2, 5, or 6	3051SMV__3 or 4 3051SF_3, 4, or 7	ERS System (3051SAM)
DP Ranges 2–5: 100 ms Range 1: 255 ms Range 0: 700 ms	100 ms	DP Range 1: 310 ms DP Range 2: 170 ms DP Range 3: 155 ms AP and GP: 240 ms	DP Ranges 2–5: 145 ms DP Range 1: 300 ms DP Range 0: 745 ms	360 ms

**Table 9: Dead Time**

For option code DA2, dead time is 90 milliseconds (nominal).

<b>3051S_C 3051S_T 3051SF_D 3051SAL_C</b>	<b>3051SMV 3051SF_1-7</b>	<b>ERS System (includes 3051SAM, 3051SAL_P, and 3051SAL_S models)</b>
45 ms (nominal)	DP: 100 ms AP and GP: 140 ms RTD Interface: 1 s	220 ms

**Table 10: Sensor Update Rate**

Does not apply to Wireless (output code X). See IEC 62591 (WirelessHART® protocol) for wireless update rate.

<b>3051S_C or T 3051SF_D 3051SAL_C</b>	<b>3051SMV 3051SF_1-7</b>	<b>ERS System (includes 3051SAM, 3051SAL_P, and 3051SAL_S models)</b>
22 updates per second	DP: 22 updates per sec. AP and GP: 11 updates per second RTD Interface: 1 update per second	Calculated variables <sup>(1)</sup> : Mass/volumetric flow rate: 22 updates per second Energy flow rate: 22 updates per second Totalized flow: 1 update per second
		11 updates per second

(1) Energy, Volumetric, and Totalized flow not available with transmitter output code F.

**Ambient temperature effect**

**Table 11: Transmitter with Coplanar Sensor Module (Single Variable)**

<b>Differential Pressure: (3051S_CD, 3051SMV__3 or 4)</b>			
<b>Gauge Pressure: (3051S_CG, 3051SAM__G<sup>(1)</sup>)</b>			
	<b>Ultra per 50 °F (28 °C)</b>	<b>Classic per 50 °F (28 °C)</b>	<b>Ultra for flow<sup>(2)</sup> -40 to 185 °F (-40 to 85 °C)</b>
Ranges 2–5 <sup>(3)</sup>	±(0.009% URL + 0.025% span) from 1:1 to 10:1; ±(0.018% URL + 0.08% span) from >10:1 to 200:1	±(0.0125% URL + 0.0625% span) from 1:1 to 5:1; ±(0.025% URL + 0.125% span) from >5:1 to 150:1	±0.13% of reading up to 8:1 DP turndown from URL; ±(0.0187% URL + 0.13% reading) > 8:1 and ≤ 100:1 DP turndown from URL
Range 0	±(0.25% URL + 0.05% span) from 1:1 to 30:1	±(0.25% URL + 0.05% span) from 1:1 to 30:1	N/A
Range 1	±(0.1% URL + 0.25% span) from 1:1 to 50:1	±(0.1% URL + 0.25% span) from 1:1 to 50:1	N/A
<b>Absolute Pressure: (3051S_CA, 3051SAM__A<sup>(1)</sup>)</b>			
	<b>Ultra per 50 °F (28 °C)</b>	<b>Classic per 50 °F (28 °C)</b>	
Ranges 2–4	±(0.0125% URL + 0.0625% span) from 1:1 to 5:1; ±(0.025% URL + 0.125% span) from >5:1 to 200:1	±(0.0125% URL + 0.0625% span) from 1:1 to 5:1; ±(0.025% URL + 0.125% span) from >5:1 to 150:1	

**Table 11: Transmitter with Coplanar Sensor Module (Single Variable) (continued)**

Range 0	$\pm(0.1\% \text{ URL} + 0.25\% \text{ span})$ from 1:1 to 30:1	$\pm(0.1\% \text{ URL} + 0.25\% \text{ span})$ from 1:1 to 30:1
Range 1	$\pm(0.0125\% \text{ URL} + 0.0625\% \text{ span})$ from 1:1 to 5:1; $\pm(0.025\% \text{ URL} + 0.125\% \text{ span})$ from >5:1 to 100:1	$\pm(0.0125\% \text{ URL} + 0.0625\% \text{ span})$ from 1:1 to 5:1; $\pm(0.025\% \text{ URL} + 0.125\% \text{ span})$ from >5:1 to 100:1

- (1) Specifications are for each gauge/absolute pressure sensor of the ERS system and are not reflective of the DP calculation.
- (2) Ultra for Flow is only available for Rosemount 3051S\_CD Ranges 2–3 and 3051SMV DP Ranges 2–3.
- (3) Use Classic specification for Rosemount 3051SMV DP Range 5 Ultra and 3051S\_CD Range 5 Ultra.

**Table 12: Ambient Temperature Effect for Transmitter with In-line Sensor Module**

Absolute Pressure: (3051S_TA, 3051SAM__E <sup>(1)</sup> ) Gauge Pressure: (3051S_TG, 3051SAM__T <sup>(1)</sup> )		
	Ultra per 50 °F (28 °C)	Classic per 50 °F (28 °C)
Ranges 2–4	$\pm(0.009\% \text{ URL} + 0.025\% \text{ span})$ from 1:1 to 10:1; $\pm(0.018\% \text{ URL} + 0.08\% \text{ span})$ from >10:1 to 200:1	$\pm(0.0125\% \text{ URL} + 0.0625\% \text{ span})$ from 1:1 to 5:1; $\pm(0.025\% \text{ URL} + 0.125\% \text{ span})$ from >5:1 to 150:1
Range 5	$\pm(0.05\% \text{ URL} + 0.075\% \text{ span})$ from 1:1 to 10:1	$\pm(0.05\% \text{ URL} + 0.075\% \text{ span})$ from 1:1 to 5:1
Range 1	$\pm(0.0125\% \text{ URL} + 0.0625\% \text{ span})$ from 1:1 to 5:1; $\pm(0.025\% \text{ URL} + 0.125\% \text{ span})$ from >5:1 to 100:1	$\pm(0.0125\% \text{ URL} + 0.0625\% \text{ span})$ from 1:1 to 5:1; $\pm(0.025\% \text{ URL} + 0.125\% \text{ span})$ from >5:1 to 100:1

- (1) Specifications are for each gauge/absolute pressure sensor of the ERS system and are not reflective of the DP calculation.

**Table 13: Ambient Temperature Effect for Transmitter with Multivariable Sensor Module**

Differential Pressure and Static Pressure (3051SMV__1 or 2)		
Models	Ultra for flow -40 to 185 °F (-40 to 85 °C) <sup>(1)</sup>	Classic MV Per 50 °F (28 °C)
DP Ranges 2–3 <sup>(2)</sup>	$\pm 0.13$ reading up to 8:1 DP turndown from URL; $\pm(0.13 + 0.0187[\text{URL}/\text{Reading}])\%$ reading to 100:1 DP turndown from URL	$\pm(0.0125\% \text{ URL} + 0.0625\% \text{ span})$ from 1:1 to 5:1; $\pm(0.025\% \text{ URL} + 0.125\% \text{ span})$ for >5:1 to 100:1
DP Range 2, SP Range 5	$\pm 0.35\%$ of reading less than or equal to 5:1 $\pm[0.35 + 0.050 (\text{URL}/\text{RDG})]\%$ of reading greater than 5:1	$\pm(0.025\% \text{ URL} + 0.100\% \text{ span})$ from 1:1 to 5:1 $\pm(0.025\% \text{ URL} + 0.125\% \text{ span})$ from 5:1 to 100:1
DP Range 3, SP Range 5	$\pm 0.25\%$ of reading less than or equal to 5:1 $\pm[0.25 + 0.045 (\text{URL}/\text{RDG})]\%$ of reading greater than 5:1	$\pm(0.025\% \text{ URL} + 0.0750\% \text{ span})$ from 1:1 to 5:1 $\pm(0.025\% \text{ URL} + 0.125\% \text{ span})$ from 5:1 to 100:1
DP Range 4	$\pm 0.130\%$ of reading less than or equal to 3:1 $\pm(0.050 + 0.065 [\text{URL}/\text{RDG}])\%$ of reading greater than 3:1	$\pm(0.025\% \text{ URL} + 0.125\% \text{ span})$ from 1:1 to 30:1 $\pm(0.035\% \text{ URL} + 0.125\% \text{ span})$ from 30:1 to 100:1
DP Range 5	N/A	$\pm(0.025\% \text{ URL} + 0.125\% \text{ span})$ from 1:1 to 30:1 $\pm(0.035\% \text{ URL} + 0.125\% \text{ span})$ from 30:1 to 100:1
DP Range 1	N/A	$\pm(0.1\% \text{ URL} + 0.25\% \text{ span})$ from 1:1 to 50:1
AP and GP	$\pm(0.009\% \text{ URL} + 0.025\% \text{ span})$ from 1:1 to 10:1; $\pm(0.018\% \text{ URL} + 0.08\% \text{ span})$ for >10:1 <sup>(3)</sup>	$\pm(0.0125\% \text{ URL} + 0.0625\% \text{ span})$ from 1:1 to 10:1; $\pm(0.025\% \text{ URL} + 0.125\% \text{ span})$ for >10:1 to 100:1

- (1) Temperature limit for 3051SMV with static pressure range 5 is -20 to 185 °F (-29 to 85 °C)

- (2) Only applies to SP ranges 3 and 4.
- (3) For DP range 4 or 5, Ultra for Flow ambient temperature effect on static pressure is  $\pm(0.0125\% \text{ URL} + 0.0625\% \text{ Span})$  from 1:1 to 10:1;  $\pm(0.025\% \text{ URL} + 0.125\% \text{ Span})$  for >10:1.

**Table 14: Ambient temperature effect for Liquid Level Transmitter**

Rosemount 3051SAL	
Ultra	Classic
See Instrument Toolkit.	See Instrument Toolkit.

### Process temperature RTD interface

**Table 15: Process Temperature (3051SMV\_\_1 or 3)**

**Note**

Lower process temperature limit for Rosemount 3051SMV static pressure range 5 is -20 °F.

Specifications for process temperature are for the transmitter portion only. The transmitter is compatible with any Pt 100 (100 ohm platinum) RTD. Examples of compatible RTDs include Rosemount series 214C RTD Temperature Sensors.

Classic MV Per 50 °F (28 °C)	Ultra for flow -40 to 185 °F (-40 to 85 °C)
$\pm 0.39$ °F (0.216 °C) per 50 °F (28 °C)	$\pm 0.39$ °F (0.216 °C) per 50 °F (28 °C)

### Line pressure effect

**Note**

The line pressure effect specifications also apply to option code P9, where applicable.

3051S_CD 3051SMV (DP measurement only) <sup>(1)</sup>	Ultra and Ultra for flow	Classic and classic MV
<b>Zero error<sup>(2)</sup></b>		
Range 2–3 <sup>(3)</sup>	$\pm 0.025\%$ URL per 1000 psi (68.95 bar)	$\pm 0.05\%$ URL per 1000 psi (68.95 bar)
DP Range 2, SP range 5	$\pm 0.075\%$ of reading per 1000 psi (68.95 bar)	$\pm 0.1\%$ of reading per 1000 psi (68.95 bar)
DP Range 3, SP range 5	$\pm 0.025\%$ URL per 1000 psi (68.95 bar)	$\pm 0.05\%$ URL per 1000 psi (68.95 bar)
Range 0	$\pm 0.125\%$ URL per 100 psi (6.89 bar)	$\pm 0.125\%$ URL per 100 psi (6.89 bar)
Range 1	$\pm 0.25\%$ URL per 1000 psi (68.95 bar)	$\pm 0.25\%$ URL per 1000 psi (68.95 bar)
<b>Span error<sup>(4)</sup></b>		
Range 2–3 <sup>(3)</sup>	$\pm 0.1\%$ of reading per 1000 psi (68.95 bar)	$\pm 0.1\%$ of reading per 1000 psi (68.95 bar)
DP Range 2, SP range 5	$\pm 0.2\%$ of reading per 1000 psi (68.95 bar)	$\pm 0.2\%$ of reading per 1000 psi (68.95 bar)
DP Range 3, SP range 5	$\pm 0.1\%$ of reading per 1000 psi (68.95 bar)	$\pm 0.1\%$ of reading per 1000 psi (68.95 bar)
Range 0	$\pm 0.15\%$ of reading per 100 psi (6.89 bar)	$\pm 0.15\%$ of reading per 100 psi (6.89 bar)
Range 1	$\pm 0.4\%$ of reading per 1000 psi (68.95 bar)	$\pm 0.4\%$ of reading per 1000 psi (68.95 bar)

- (1) Lower process temperature limit for Rosemount 3051SMV static pressure range 5 is -20 °F (6.7 °C).
- (2) Zero error can be removed by performing a zero trim at line pressure.
- (3) Only available with SP ranges 3 and 4.
- (4) Specifications for option code P0 are two times those shown above.

### Mounting position effects

Models		Ultra, Ultra for flow, Classic and Classic MV
3051S_CD or CG 3051SMV__ 3 or 4 3051SF_3, 4, 7, or D 3051SAM__G		Zero shifts up to ±1.25 inH <sub>2</sub> O (3.11 mbar), which can be zeroed span: no effect
3051S_CA 3051S_T 3051SAM__A, T, or E		Zero shifts to ±2.5 inH <sub>2</sub> O (6.22 mbar), which can be zeroed span: no effect
3051SMV__ 1 or 2 3051SF_1, 2, 5, or 6	DP Sensor	Zero shifts up to ±1.25 inH <sub>2</sub> O (3.11 mbar), which can be zeroed span: no effect
	GP/AP Sensor	Zero shifts to ±2.5 inH <sub>2</sub> O (6.22 mbar), which can be zeroed span: no effect
3051SAL		With liquid level diaphragm in vertical plane, zero shift of up to ±1 inH <sub>2</sub> O (2.49 mbar). With diaphragm in vertical plane, zero shift of up to ±5 inH <sub>2</sub> O (12.43 mbar) plus extension length on extended units. All zero shifts can be zeroed. Span: no effect

### Vibration effect

Less than ±0.1 percent of URL when tested per the requirements of IEC60770-1 field or pipeline with high vibration level (10–60 Hz 0.21 mm displacement peak amplitude/60–2000 Hz 3 g).

For Housing Style codes 1J, 1K, 1L, 2J, and 2M: Less than ±0.1 percent of URL when tested per the requirements of IEC60770-1 field with general application or pipeline with low vibration level (10–60 Hz 0.15 mm displacement peak amplitude/60–500 Hz 2 g).

### Power supply effect

Less than ±0.005 percent of calibrated span per volt change in voltage at the transmitter terminals

### Electromagnetic compatibility

Meets all industrial environment requirements of EN61326 and NAMUR NE-21. Maximum deviation <1 percent Span during EMC disturbance.

### Transient protection (option T1)

Tested in accordance with IEEE C62.41.2-2002, Location Category B

- 6 kV crest (0.5 μs – 100 kHz)
- 3 kA crest (8 × 20 μs)
- 6 kV crest (1.2 × 50 μs)



## Functional specifications

### Range and sensor limits

**Table 16: Transmitter with Coplanar Sensor Module (Single Variable)**

Range	DP sensor <sup>(1)</sup> (3051S_CD, 3051SMV__3, 4, or D 3051SF_3, 4, or 7, 3051SAL_CD)		GP sensor (3051S_CG, 3051SAM__G, 3051SAL__G)		AP sensor <sup>(2)</sup> (3051S_CA, 3051SAM__A, 3051SAL__A)	
	Lower (LRL) <sup>(3)</sup>	Upper (URL)	Lower (LRL) <sup>(4)</sup>	Upper (URL)	Lower (LRL)	Upper (URL)
0	-3.00 inH <sub>2</sub> O (-7.46 mbar)	3.00 inH <sub>2</sub> O (7.46 mbar)	N/A	N/A	0 psia (0 bar)	5.00 psia (0.34 bar)
1	-25.00 inH <sub>2</sub> O (-62.16 mbar)	25.00 inH <sub>2</sub> O (62.16 mbar)	-25.00 inH <sub>2</sub> O (-62.16 mbar)	25.00 inH <sub>2</sub> O (62.16 mbar)	0 psia (0 bar)	30.00 psia (2.07 bar)
2	-250.00 inH <sub>2</sub> O (-621.60 mbar)	250.00 inH <sub>2</sub> O (621.60 mbar)	-250.00 inH <sub>2</sub> O (-621.60 mbar)	250.00 inH <sub>2</sub> O (621.60 mbar)	0 psia (0 bar)	150.00 psia (10.34 bar)
3	-1000.00 inH <sub>2</sub> O (-2.49 bar)	1000.00 inH <sub>2</sub> O (2.49 bar)	0.5 psia (34.47 mbar)	1000.00 inH <sub>2</sub> O (2.49 bar)	0 psia (0 bar)	800.00 psia (55.16 bar)
4	-300.00 psi (-20.68 bar)	300.00 psi (20.68 bar)	0.5 psia (34.47 mbar)	300.00 psi (20.68 bar)	0 psia (0 bar)	4000.00 psia (275.79 bar)
5	-2000.00 psi (-137.90 bar)	2000.00 psi (137.90 bar)	0.5 psia (34.47 mbar)	2000.00 psi (137.90 bar)	N/A	N/A

(1) Rosemount 3051SF flow meters only available with ranges 1, 2, and 3.

(2) Range 0 is not available for 3051SAL\_\_A.

(3) The Lower Range Limit (LRL) is 0 inH<sub>2</sub>O (0 mbar) for Ultra for Flow Performance Class and Rosemount 3051SF flow meters.

(4) Assumes atmospheric pressure of 14.7 psia (1 bar).

**Table 17: Transmitter with In-Line Sensor Module**

Range	GP sensor (3051S_TG, 3051SAM__T, 3051SAL__T)		AP sensor (3051S_TA, 3051SAM__E, 3051SAL__E)	
	Lower (LRL) <sup>(1)</sup>	Upper (URL)	Lower (LRL)	Upper (URL)
1	-14.70 psig (-1.01 bar)	30.00 psig (2.07 bar)	0 psia (0 bar)	30.00 psia (2.07 bar)
2	-14.70 psig (-1.01 bar)	150.00 psig (10.34 bar)	0 psia (0 bar)	150.00 psia (10.34 bar)
3	-14.70 psig (-1.01 bar)	800.00 psig (55.16 bar)	0 psia (0 bar)	800.00 psia (55.16 bar)
4	-14.70 psig (-1.01 bar)	4000.00 psig (275.79 bar)	0 psia (0 bar)	4000.00 psia (275.79 bar)
5	-14.70 psig (-1.01 bar)	10000.00 psig (689.48 bar)	0 psia (0 bar)	10000.00 psia (689.48 bar)

(1) Assumes atmospheric pressure of 14.7 psia (1 bar-a).

**Table 18: Transmitter with Multivariable Sensor Module (3051SMV\_\_1, 3051SMV\_\_2, 3051SF\_1, 3051SF\_2, 3051SF\_5, and 3051SF\_6)**

Range	DP sensor	
	Lower (LRL) <sup>(1)</sup>	Upper (URL)
1	-25.00 inH <sub>2</sub> O (-62.30 mbar)	25.00 inH <sub>2</sub> O (62.30 mbar)
2	-250.00 inH <sub>2</sub> O (-0.62 bar)	250.00 inH <sub>2</sub> O (0.62 bar)

**Table 18: Transmitter with Multivariable Sensor Module (3051SMV\_\_1, 3051SMV\_\_2, 3051SF\_1, 3051SF\_2, 3051SF\_5, and 3051SF\_6) (continued)**

Range	DP sensor	
	Lower (LRL) <sup>(1)</sup>	Upper (URL)
3	-1000.00 inH <sub>2</sub> O (-2.49 bar)	1000.00 inH <sub>2</sub> O (2.49 bar)
4	-150.00 psi (-10.30 bar)	150.00 psi (10.30 bar)
5	-2000.00 psi (-137.90 bar)	2000.00 psi (137.90 bar)

(1) Lower (LRL) is 0 inH<sub>2</sub>O (0 mbar) for Ultra for Flow and Rosemount 3051SF\_flow meters.

**Table 19: Static Pressure Sensor (GP/AP)**

Range	Lower (LRL)	Upper (URL) <sup>(1)</sup>
3	GP <sup>(2)(3)</sup> : -14.20 psig (-0.98 bar) AP: 0.50 psia (34.5 mbar)	GP: 800 psig (55.16 bar) AP: 800 psia (55.16 bar)
4	GP <sup>(2)(3)</sup> : -14.20 psig (-0.98 bar) AP: 0.50 psia (34.5 mbar)	GP: 3626 psig (250.0 bar) AP: 3626 psia (250.0 bar)
5	GP <sup>(2)(3)(4)</sup> : -14.20 psig (-0.98 bar)	GP <sup>(5)</sup> : 6092 psi (420 bar)

(1) For SP Range 4 with DP Range 1, the URL is 2000 psi (137.9 bar).

(2) Inert fill: minimum pressure = 1.5 psia (0.10 bar) or -13.2 psig (-0.91 bar).

(3) Assumes atmospheric pressure of 14.7 psia (1 bar-a).

(4) Static pressure range 5 is a sealed gauge sensor.

(5) For temperature range -40 to -20 °F URL is 4500 PSI (310.26 bar), for temperature range -20 to 185 °F URL is 6092 PSI (420 bar).

**Table 20: Process Temperature RTD Interface (3051SMV\_\_1 or 3, 3051SF\_1, 3, 5 or 7)**

Transmitter is compatible with any Pt 100 RTD sensor. Examples of compatible RTDs include Rosemount Series 214C RTD Temperature Sensors.

Lower (LRL)	Upper (URL)
-328 °F (-200 °C)	1562 °F (850 °C)

### Minimum span limits

**Table 21: Transmitter with Coplanar Sensor Module (Single Variable)**

Range	DP sensor <sup>(1)</sup> (3051S_CD, 3051SMV__3 or 4, 3051SF_D, 3, 4 or 7, 3051SAL__CD <sup>(2)</sup> )		GP sensor (3051S_CG, 3051SAM__G <sup>(3)</sup> , 3051SAL__G <sup>(2)(3)</sup> )		AP sensor (3051S_CA, 3051SAM__A <sup>(3)</sup> , 3051SAL__A <sup>(2)(3)</sup> )	
	Ultra and Ultra for Flow	Classic	Ultra	Classic	Ultra	Classic
0	0.10 inH <sub>2</sub> O (0.25 mbar)	0.10 inH <sub>2</sub> O (0.25 mbar)	N/A	N/A	0.167 psia (11.49 mbar)	0.167 psia (11.49 mbar)
1	0.50 inH <sub>2</sub> O (1.24 mbar)	0.50 inH <sub>2</sub> O (1.24 mbar)	0.50 inH <sub>2</sub> O (1.24 mbar)	0.50 inH <sub>2</sub> O (1.24 mbar)	0.30 psia (20.68 mbar)	0.30 psia (20.68 mbar)
2	1.25 inH <sub>2</sub> O (3.11 mbar)	1.67 inH <sub>2</sub> O (4.14 mbar)	1.25 inH <sub>2</sub> O (3.11 mbar)	1.67 inH <sub>2</sub> O (4.14 mbar)	0.75 psia (51.71 mbar)	1.00 psia (68.95 mbar)
3	5.0 inH <sub>2</sub> O (12.44 mbar)	6.67 inH <sub>2</sub> O (16.58 mbar)	5.0 inH <sub>2</sub> O (12.44 mbar)	6.67 inH <sub>2</sub> O (16.58 mbar)	4.00 psia (275.79 mbar)	5.33 psia (367.72 mbar)

**Table 21: Transmitter with Coplanar Sensor Module (Single Variable) (continued)**

Range	DP sensor <sup>(1)</sup> (3051S_CD, 3051SMV__3 or 4, 3051SF_D, 3, 4 or 7, 3051SAL__CD <sup>(2)</sup> )		GP sensor (3051S_CG, 3051SAM__G <sup>(3)</sup> , 3051SAL__G <sup>(2)(3)</sup> )		AP sensor (3051S_CA, 3051SAM__A <sup>(3)</sup> , 3051SAL__A <sup>(2)(3)</sup> )	
	Ultra and Ultra for Flow	Classic	Ultra	Classic	Ultra	Classic
4	1.50 psi (103.42 mbar)	2.00 psi (137.90 mbar)	1.50 psig (103.42 mbar)	2.00 psig (137.90 mbar)	20.00 psia (1.38 bar)	26.67 psia (1.84 bar)
5	10.00 psi (689.48 mbar)	13.33 psi (919.30 mbar)	10.00 psig (689.48 mbar)	13.33 psig (919.30 mbar)	N/A	N/A

- (1) Rosemount 3051SF flow meters only available with ranges 1, 2, and 3.
- (2) For Rosemount 3051SAL models, use Classic minimum span limits.
- (3) Specifications are for each gauge/absolute pressure sensor of the ERS system and are not reflective of the DP calculation.

**Table 22: Transmitter with In-Line Sensor Module**

Range	GP sensor (3051S_TG, 3051SAM__T <sup>(1)</sup> , 3051SAL__T <sup>(2)</sup> )		AP sensor (3051S_TA, 3051SAM__E <sup>(1)</sup> , 3051SAL__E <sup>(2)</sup> )	
	Ultra	Classic	Ultra	Classic
1	0.30 psig (20.68 mbar)	0.30 psig (20.68 mbar)	0.30 psia (20.68 mbar)	0.30 psia (20.68 mbar)
2	0.75 psig (51.71 mbar)	1.00 psig (68.95 mbar)	0.75 psia (51.71 mbar)	1.00 psia (68.95 mbar)
3	4.00 psig (275.79 mbar)	5.33 psig (367.72 mbar)	4.00 psia (275.79 mbar)	5.33 psia (367.72 mbar)
4	20.00 psig (1.38 bar)	26.67 psig (1.84 bar)	20.00 psia (1.38 bar)	26.67 psia (1.84 bar)
5	1000.00 psig (68.95 bar)	2000.00 psig (137.90 bar)	1000.00 psia (68.95 bar)	2000.00 psia (137.90 bar)

- (1) Specifications are for each gauge/absolute pressure sensor of the ERS system and are not reflective of the DP calculation.
- (2) For Rosemount 3051SAL models, use classic minimum span limits.

**Table 23: Transmitter with Multivariable Sensor Module (3051SMV\_\_1 or 2, 3051SF\_1, 2, 5, or 6)**

Range	DP sensor	
	Ultra for Flow	Classic MV
1	N/A	0.5 inH <sub>2</sub> O (1.24 mbar)
2	1.3 inH <sub>2</sub> O (3.23 mbar)	2.5 inH <sub>2</sub> O (6.22 mbar)
3	5.0 inH <sub>2</sub> O (12.43 mbar)	10.0 inH <sub>2</sub> O (24.86 mbar)
4	1.5 psi (103.42 mbar)	3.0 psi (206.84 mbar)
5	N/A	20.0 psi (1.38 bar)
Range	Static pressure sensor (GP/AP)	
	Ultra for Flow	Classic MV
3	4.0 psi (275.79 mbar)	8.0 psi (551.58 mbar)
4	18.13 psi (1.25 bar)	36.26 psi (2.50 bar)
5	1000 psi (68.95 bar)	2000 psi (137.90 bar)

**Process temperature RTD interface (3051SMV\_\_1 or 3, 3051SF\_1, 3, 5 or 7)**

Minimum span = 50 °F (28 °C)

### DP span considerations for ERS applications

It is recommended that the DP rangedown (operating pressure/DP span) for ERS applications not exceed 100:1. Consult with Emerson sales representative when considering a Rosemount 3051S ERS System for applications beyond 100:1 rangedown.

## Service

### Rosemount 3051S, 3051SMV\_P, 3051SAM, and 3051SF\_5, 6, 7, or D (Direct Process Variable Output)

Liquid, gas, and vapor applications

### Rosemount 3051SAL

Liquid level applications

### Rosemount 3051SMV\_M and 3051SF\_1, 2, 3, or 4 (Mass and Energy Flow Output)

#### Note

For option code A: 4-20mA HART only.

Some fluid types are only supported by certain measurement types.

**Table 24: Fluid Compatibility with Pressure and Temperature Compensation**

- Available — Not available

Code	Measurement type	Fluid types			
		Liquids	Saturated steam	Superheated steam	Gas and natural gas
1	DP/P/T (full compensation)	•	•	•	•
2	DP/P	•	•	•	•
3	DP/T	•	•	—	—
4	DP only	•	•	—	—

## 4–20 mA HART® protocol

### Zero and span adjustment

Zero and span values can be set anywhere within the range. Span must be greater than or equal to the minimum span.

### Output

The 2-wire 4–20 mA is user-selectable for linear or square root output. Digital process variable superimposed on 4–20 mA signal is available to any host that conforms to the HART protocol.

### Power supply

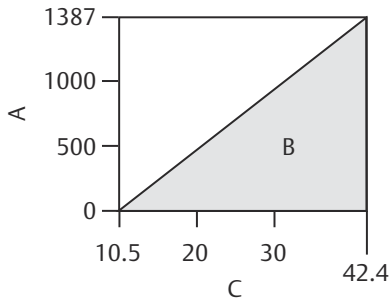
External power supply required.

- Rosemount 3051S and 3051SF\_D: 10.5 to 42.4 Vdc with no load
- Rosemount 3051S and 3051SF\_D with Advanced HART Diagnostics Suite: 12 to 42.4 Vdc with no load
- Rosemount 3051SMV and 3051SF\_1-7: 12 to 42.4 Vdc with no load
- Rosemount 3051S ERS System: 16.0 to 42.4 Vdc with no load

### Load limitations

Maximum loop resistance is determined by the voltage level of the external power supply, as described by:

**Figure 7: Rosemount 3051S and 3051SF\_D**

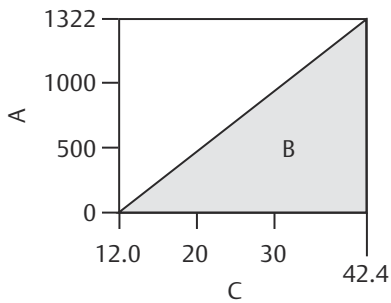


Maximum Loop Resistance =  $43.5 \times (\text{Power Supply Voltage} - 10.5)$

The Field Communicator requires a minimum loop resistance of 250 Ω for communication.

- A. Load (ohms)
- B. Operating region
- C. Voltage (Vdc)

**Figure 8: Rosemount 3051SMV and 3051SF\_1-7, 3051S and 3051SF\_D with HART Diagnostics (option code DA2)**

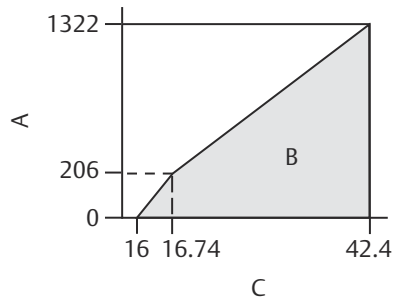


Maximum Loop Resistance =  $43.5 \times (\text{Power Supply Voltage} - 12.0)$

The Field Communicator requires a minimum loop resistance of 250 Ω for communication.

- A. Load (ohms)
- B. Operating region
- C. Voltage (Vdc)

Figure 9: Rosemount 3051S ERS System



If supply voltage  $\leq 16.74$  Vdc: Maximum Loop Resistance =  $277 \times (\text{Power Supply Voltage} - 16.0)$   
 If supply voltage  $> 16.74$  Vdc: Maximum Loop Resistance =  $43.5 \times (\text{Power Supply Voltage} - 12.0)$

The Field Communicator requires a minimum loop resistance of  $250 \Omega$  for communication.

- A. Load (ohms)
- B. Operating region
- C. Voltage (Vdc)

### Selectable HART revisions (option code HR7)

The 2-wire 4–20 mA is user-selectable for linear or square root output. Digital process variable superimposed on 4–20 mA signal is available to any host that conforms to HART protocol. The Rosemount 3051S with Advanced HART Diagnostics (DA2) comes with Selectable HART revisions. Digital communications based on HART Revision 7 (with option code HR7 selected) or Revision 5 (default) protocol can be selected. The HART revision can be switched in the field using any HART-based configuration. See the Rosemount 3051S [Reference Manual](#) for instructions on how to switch HART revision.

### Advanced HART diagnostics suite (Option Code DA2)

The Process Intelligence diagnostic provides statistical data (standard deviation, mean, coefficient of variation) that can be used to detect process and process equipment anomalies including but not limited to:

- Furnace flame instability
- Pump cavitation
- Distillation column flooding
- Fluid composition change
- Entrained air
- Agitation loss
- Process leak

This diagnostic allows you to take preventative measures before abnormal process situations result in unscheduled downtime or rework.

The Loop Integrity diagnostic pro-actively detects and notifies you of changes in the electrical loop before they affect your process operation. Example loop problems that can be detected include water in the terminal compartment, corrosion of terminals, improper grounding, and unstable power supplies.

The Plugged Impulse Line diagnostic uses the same statistical processing technology as Process Intelligence to detect plugging in impulse piping that may prevent the transmitter from obtaining an accurate process reading. It can also detect and alert you to other process connection issues, such as plugged Annubar or orifice plate process taps.

The Device Dashboard presents the diagnostics in a graphical, task-based interface that provides single click access to critical process/device information and descriptive graphical troubleshooting.

Suite includes: Process Intelligence, Loop Integrity, Plugged Impulse Line, Status Log, Variable Log, Advanced Process Alerts, Service Alerts, and Time Stamp capability.

## FOUNDATION™ Fieldbus protocol

### Power supply

External power supply required; transmitters operate on 9.0–32.0 Vdc (9.0–17.5 Vdc for FISCO) transmitter terminal voltage.

### Current draw

17.5 mA for all configurations (including LCD display option)

Parameters:

- Schedule entries: 22 (max.)
- Links: 25 (max.)
- Virtual Communications Relationships (VCR): 20 (max.)

### Standard function blocks

<b>Resource block</b>	Contains hardware, electronics, and diagnostic information.
<b>Transducer block</b>	Contains actual sensor measurement data including the sensor diagnostics and the ability to trim the pressure sensor or recall factory defaults.
<b>LCD display block</b>	Configures the local display.
<b>Analog Input blocks</b>	Processes the measurements for input into other function blocks. The output value is in engineering or custom units and contains a status indicating measurement quality.
<b>PID block with auto-tune</b>	Contains all logic to perform PID control in the field including cascade and feedforward. Auto-tune capability allows for superior tuning for optimized control performance.

### Backup Link Active Scheduler (LAS)

The transmitter can function as a Link Active Scheduler if the current link master device fails or is removed from the segment.

### Software upgrade in the field

Software for the Rosemount 3051S with FOUNDATION Fieldbus is easy to upgrade in the field using the FOUNDATION Fieldbus Common Device Software Download procedure.

### Plantweb alerts

Enable the full power of the Plantweb digital architecture by diagnosing instrumentation issues, communicating advisory, maintenance, and failure details, and recommending a solution.

### Advanced control function block suite (option code A01)

<b>Input selector block</b>	Selects between inputs and generates an output using specific selection strategies such as minimum, maximum, midpoint, average, or first “good.”
<b>Arithmetic block</b>	Provides pre-defined application-based equations including flow with partial density compensation, electronic remote sensors, hydrostatic tank gauging, ratio control and others.
<b>Signal characterizer block</b>	Characterizes or approximates any function that defines an input/output relationship by configuring up to twenty X, Y coordinates. The block interpolates an output value for a given input value using the curve defined by the configured coordinates.
<b>Integrator block</b>	Compares the integrated or accumulated value from one or two variables to pre-trip and trip limits and generates discrete output signals when the limits are reached. This block is useful for calculating total flow, total mass, or volume over time.
<b>Output splitter block</b>	Splits the output of one PID or other control block so that the PID will control two valves or other actuators.
<b>Control selector block</b>	Selects one of up to three inputs (highest, middle, or lowest) that are normally connected to the outputs of PID or other control function blocks.

Block	Execution time
Resource	N/A
Transducer	N/A
LCD Display Block	N/A
Analog Input 1	20 milliseconds
PID with Auto-tune	35 milliseconds
Input Selector	20 milliseconds
Arithmetic	20 milliseconds
Signal Characterizer	20 milliseconds
Integrator	20 milliseconds
Output Splitter	20 milliseconds
Control Selector	20 milliseconds

### FOUNDATION Fieldbus diagnostics suite (option code D01)

#### Note

Only applies to Rosemount 3051S with transmitter output code F.

Process Intelligence provides statistical data (standard deviation and mean) that can be used to detect process and process equipment anomalies, including:

- furnace flame instability
- pump cavitation
- distillation column flooding
- fluid composition change
- entrained air
- agitation loss
- process leak

This diagnostic allows you to take preventative measures before abnormal process situations result in unscheduled downtime or rework.

The Plugged Impulse Line diagnostic uses the same statistical processing technology as Process Intelligence to detect plugging in impulse piping that may prevent the transmitter from obtaining an accurate process reading. It can also detect and alert you to other process connection issues, such as plugged Annubar or orifice plate process taps.

The Device Dashboard presents the diagnostics in a graphical, task-based interface that provides single click access to critical process/device information and descriptive graphical troubleshooting.

Suite includes: Process Intelligence and Plugged Impulse Line diagnostics.

### IEC 62591 (*WirelessHART*<sup>®</sup> protocol)

#### Output

IEC 62591 (*WirelessHART*), 2.4 GHz DSSS

#### Radio frequency power output from antenna

- External antenna (WK option): Maximum of 10 mW (10 dBm) EIRP



- Extended range, external antenna (WM option): Maximum of 18 mW (12.5 dBm) EIRP
- Remote (WJ option) antenna: Maximum of 17 mW (12.3 dBm) EIRP
- High-gain, remote antenna (WN option): Maximum of 40 mW (16 dBm) EIRP

**Local display**

The optional seven-digit LCD display can display user-selectable information such as primary variable in engineering units, percent of range, sensor module temperature, and electronics temperature. The display updates based on the wireless update rate.

**Update rate**

User selectable 1 second to 60 minutes.

**Power module**

Field replaceable, keyed connection eliminates the risk of incorrect installation, Intrinsically Safe Lithium-thionyl chloride Power Module with polybutadiene terephthalate (PBT) enclosure. Ten-year life at one minute update rate.<sup>(1)(2)</sup>

**Overpressure limits**

Transmitters withstand the following limits without damage:

**Table 25: Coplanar Sensor Module (Single Variable)**

Range	DP <sup>(1)</sup> and GP	AP
	3051S_CD, 3051S_CG 3051SMV__3 or 4 3051SF_3, 4, 7, or D 3051SAM__G	3051S_CA 3051SAM__A
0	750 psi (51.71 bar)	60 psia (4.14 bar)
1	2000 psi (137.90 bar)	750 psia (51.71 bar)
2	3626 psi (250.00 bar)	1500 psia (103.42 bar)
3	3626 psi (250.00 bar)	1600 psia (110.32 bar)
4	3626 psi (250.00 bar)	6000 psia (413.69 bar)
5	3626 psi (250.00 bar)	N/A

(1) The overpressure limit of a DP Sensor with the P9 option is 4500 psig (310.3 bar). The overpressure limit of a DP Sensor with the P0 option is 6092 psig (420 bar).

**Table 26: In-Line Sensor Module**

Range	GP	AP
	3051S_TG 3051SAM__T	3051S_TA 3051SAM__E
1	750 psi (51.71 bar)	
2	1500 psi (103.42 bar)	
3	1600 psi (110.32 bar)	
4	6000 psi (413.69 bar)	
5	15000 psi (1034.21 bar)	

(1) Reference conditions are 70 °F (21 °C), and routing data for three additional network devices. Note: Continuous exposure to ambient temperature limits of -40 °F or 185 °F (-40 °C or 85 °C) may reduce specified life by less than 20 percent.  
 (2) 6.5-year life at one minute update rates when used with 3051SMV.

**Coplanar multivariable sensor module (3051SMV\_\_1 or 2, 3051SF\_1, 2, 5, or 6)**

DP range	Static pressure range (GP/AP) <sup>(1)</sup>		
	3	4	5 <sup>(2)</sup>
1	1600 psi (110.32 bar)	2000 psi (137.90 bar)	N/A
2	1600 psi (110.32 bar)	3626 psi (250.00 bar)	3626 psi (250.00 bar) if applied to one side 6500 psi (448,16 bar) if applied to both sides
3	1600 psi (110.32 bar)	3626 psi (250.00 bar)	
4	N/A	3626 psi (250.00 bar)	
5	N/A	3626 psi (250.00 bar)	N/A

- (1) Pressure can be applied to one or both sides.
- (2) Static pressure range 5 is a sealed gauge sensor.

**Liquid level transmitter (Rosemount 3051SAL)**

Overpressure limit is dependent on the flange rating or sensor rating (whichever is lower). Use Instrument Toolkit to ensure the seal system meets all pressure and temperature limits.

**Static pressure limits**

**Coplanar sensor module (single variable)**

Operates within specifications between static line pressures of:

Range	DP sensor <sup>(1)</sup>
	3051S_CD 3051SMV__3 or 4 3051SF_3, 4, 7, or D
0	0.5 psia to 750 psig (0.03 to 51.71 bar)
1	0.5 psia to 2000 psig (0.03 to 137.90 bar)
2	0.5 psia to 3626 psig (0.03 to 250.00 bar)
3	0.5 psia to 3626 psig (0.03 to 250.00 bar)
4	0.5 psia to 3626 psig (0.03 to 250.00 bar)
5	0.5 psia to 3626 psig (0.03 to 250.00 bar)

- (1) The static pressure limit of a DP Sensor with the P9 option is 4500 psig (310,26 bar). The static pressure limit of a DP Sensor with the P0 option is 6092 psig (420,00 bar).

**Coplanar multivariable sensor module**

(3051SMV\_\_1 or 2, 3051SF\_1, 2, 5, or 6)

Operates within specifications between static line pressures of 0.5 psia (0.03 bar) and the values in the table below:

DP range	Static pressure range (GP/AP)		
	3	4	5 <sup>(1)</sup>
1	800 psi (55.15 bar)	2000 psi (137.90 bar)	N/A
2	800 psi (55.15 bar)	3626 psi (250.00 bar)	6092 psi (420.00 bar)
3	800 psi (55.15 bar)	3626 psi (250.00 bar)	6092 psi (420.00 bar)
4	N/A	3626 psi (250.00 bar)	6092 psi (420.00 bar)

5	N/A	3626 psi (250.00 bar)	N/A
---	-----	-----------------------	-----

(1) Static pressure range 5 is a sealed gauge sensor.

### Maximum working pressure limits

Maximum working pressure is the maximum pressure allowed for normal transmitter operation. For a differential pressure transmitter, the maximum working pressure is the static line pressure under which the transmitter can safely operate. If one side of the transmitter is exposed to the full static line pressure due to mis-valving, the transmitter will experience an output shift and must be re-zeroed. For a gauge or absolute pressure transmitter, the maximum working pressure is the same as the Upper Range Limit (URL). The maximum working pressure of transmitters with assemble-to options is limited by the lowest maximum pressure rating of the individual components.

**Table 27: Rosemount 3051S Maximum Working Pressure**

Range	3051S_CD 3051SAL_ _D 3051SAM_ _D	3051S_CG 3051SAL_ _G 3051SAM_ _G	3051S_CA 3051SAL_ _A 3051SAM_ _A	3051S_TA 3051SAL_ _E 3051SAM_ _E	3051S_TG 3051SAL_ _T 3051SAM_ _T
0	750 psi 51.7 bar 5.17 mPa	N/A	5 psia 0.35 bar-a .035 mPa	N/A	N/A
1	2000 psi 138 bar 13.8 mPa	0.9 psi 0.062 bar 0.0062 mPa	30 psia 2.07 bar-a 0.207 mPa	30 psia 2.07 bar-a 0.207 mPa	30 psi 2.07 bar-a 0.207 mPa
2	3626 psi 250 bar 25 mPa	9 psi 0.62 bar 0.062 mPa	150 psia 10.3 bar-a 1.03 mPa	150 psia 10.3 bar-a 1.03 mPa	150 psi 10.3 bar-a 1.03 mPa
3	3626 psi 250 bar 25 mPa	36 psi 2.48 bar 0.248 mPa	800 psia 55.2 bar-a 5.52 mPa	800 psia 55.2 bar-a 5.52 mPa	800 psi 55.2 bar-a 5.52 mPa
4	3626 psi 250 bar 25 mPa	300 psi 20.7 bar 2.07 mPa	4000 psia 276 bar-a 27.6 mPa	4000 psia 276 bar-a 27.6 mPa	4000 psi 276 bar-a 27.6 mPa
5	3626 psi 250 bar 25 mPa	2000 psi 138 bar 13.8 mPa	N/A	10000psia 690 bar-a 69.0 mPa	10000 psi 690 bar-a 69.0 mPa

**Note**

The maximum working pressure limit of a DP Sensor with the P9 option is 4500 psig (310,26 bar). The maximum working pressure limit of a DP Sensor with the P0 option is 6092 psig (420,00 bar).

**Table 28: Rosemount 3051SMV Maximum Working Pressure**

DP range	Static pressure range (GP/AP)		
	3	4	5
1	800 psi 55.2 bar 5.52 mPa	2000 psi 138 bar 13.8 mPa	N/A
2	800 psi 55.2 bar 5.52 mPa	3626 psi 250 bar 25 mPa	6092 psi 420 bar 42.0 mPa

Table 28: Rosemount 3051SMV Maximum Working Pressure (*continued*)

DP range	Static pressure range (GP/AP)		
	3	4	5
3	800 psi 55.2 bar 5.52 mPa	3626 psi 250 bar 25 mPa	6092 psi 420 bar 42.0 mPa
4	N/A	3626 psi 250 bar 25 mPa	6092 psi 420 bar 42.0 mPa
5	N/A	3626 psi 250 bar 25 mPa	N/A

### Burst pressure limits

#### Coplanar sensor module (3051S\_C, 3051SMV, 3051SF, 3051SAM\_\_G or A)

10000 psig (689.47 bar)

#### DP range 2-4, static pressure range 5

16400 PSI (1130.74 bar)

#### In-line sensor module (3051S\_T, 3051SAM\_\_T or E)

- Ranges 1-4: 11000 psi (758.42 bar)
- Range 5: 26000 psi (1792.64 bar)

### Temperature limits

#### Ambient

–40 to 185 °F (–40 to 85 °C)

With LCD display<sup>(3)</sup>: –40 to 176 °F (–40 to 80 °C)

With option code P0: –20 to 185 °F (–28 to 85 °C)

With option code BR6: –76 to 185 °F (–60 to 85 °C)

Rosemount 3051SMV with SP Range 5: –20 to 185 °F (–28 to 85 °C)

#### Storage

–50 to 185 °F (–46 to 85 °C)

With LCD display: –40 to 185 °F (–40 to 85 °C)

With wireless output: –40 to 185 °F (–40 to 85 °C)

With option code BR6: –76 to 185 °F (–60 to 85 °C)

#### Process temperature limits

At atmospheric pressures and above:

(3) LCD display may not be readable and LCD display updates will be slower at temperatures below –4 °F (–20 °C) to –40 °F (–40 °C). LCD display may be ordered with option code BR6, but the display is not functional below –40 °F (–40 °C). Functionality recovers as temperature reaches –4 °F (–20 °C) again.

<b>Coplanar sensor module</b> <b>3051S_C, 3051SMV<sup>(1)</sup>, 3051SF, 3051SAM__G or A</b>	
Silicone fill sensor	N/A
with coplanar flange <sup>(2)</sup>	-40 to 250 °F (-40 to 121 °C) <sup>(3)</sup>
with traditional flange <sup>(4)</sup>	-40 to 300 °F (-40 to 149 °C) <sup>(3)(5)</sup>
with level flange <sup>(4)</sup>	-40 to 300 °F (-40 to 149 °C) <sup>(3)</sup>
with Rosemount 305 integral manifold <sup>(2)</sup>	-40 to 300 °F (-40 to 149 °C) <sup>(3)(5)</sup>
Inert fill sensor <sup>(2)</sup>	-40 to 185 °F (-40 to 85 °C) <sup>(6)(7)</sup>
with Option Code BR6, coplanar flange	-76 to 250 °F (-60 to 121 °C) <sup>(3)</sup>
with Option Code BR6, traditional flange	-75 to 300 °F (-60 to 149 °C) <sup>(3)</sup>
<b>In-line sensor module</b> <b>3051S_T, 3051SAM__T or E</b>	
Silicone fill sensor <sup>(2)</sup>	-40 to 250 °F (-40 to 121 °C) <sup>(3)</sup>
with Option Code BR6	-76 to 250 °F (-60 to 121 °C) <sup>(3)</sup>
Inert fill sensor <sup>(2)</sup>	-22 to 250 °F (-30 to 121 °C) <sup>(3)</sup>
<b>Rosemount 3051SAL Level Transmitter</b>	
SYLTHERM XLT	-157 to 293 °F (-105 to 145 °C)
Silicone 704 <sup>(8)</sup>	32 to 599 °F (0 to 315 °C)
Silicone 705 <sup>(8)</sup>	68 to 698 °F (20 to 370 °C)
UltraTherm 805	770 °F (410 °C) with 850 °F (454 °C) design <sup>(9)</sup>
Silicone 200	-49 to 401 °F (-45 to 205 °C)
Tri-Therm 300	-40 to 401 °F (-40 to 205 °C)
Inert (Halocarbon)	-49 to 320 °F (-45 to 160 °C)
Glycerin and water <sup>(10)(11)</sup>	5 to 203 °F (-15 to 95 °C)
Neobee M-20 <sup>(10)</sup>	5 to 437 °F (-15 to 225 °C)
Propylene glycol and water <sup>(10)(11)</sup>	5 to 203 °F (-15 to 95 °C)

(1) Lower process temp limit for 3051SMV static pressure range 5 is -20 °F.

(2) The maximum ambient temperature is reduced by 1.5° for every degree by which the process fluid temperature exceeds 185 °F (85 °C).

(3) 220 °F (104 °C) limit in vacuum service; 130 °F (54 °C) for pressures below 0.5 psia.

(4) The maximum ambient temperature is reduced by 1.0° for every degree by which the process fluid temperature exceeds 185 °F (85 °C) for all traditional flanges and vertical mount level flanges.

(5) -20 °F (-29 °C) is the lower process temperature limit with option code P0.

(6) 160 °F (71 °C) limit in vacuum service.

(7) Not available for 3051S\_CA.

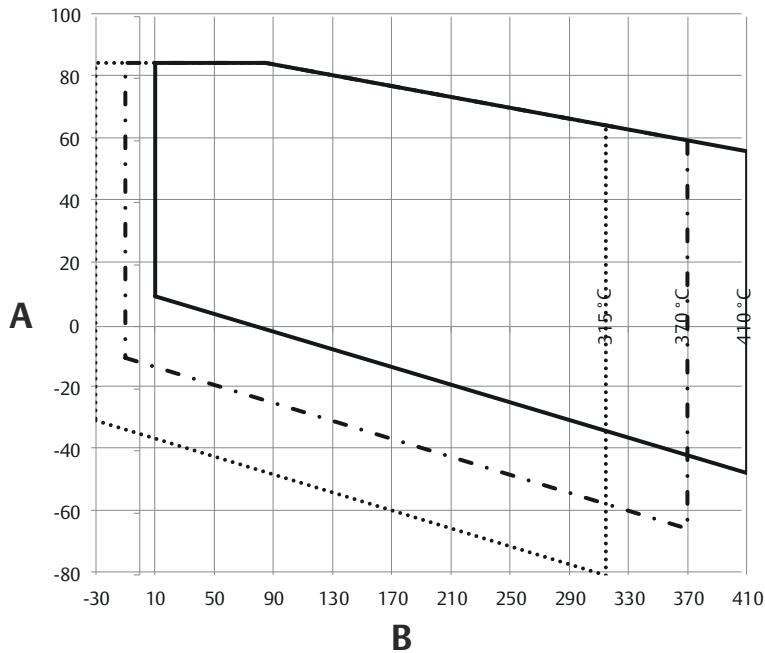
(8) Only available with Seal Connection Type/Capillary ID, Description Codes C, D, F, G, J, K, N, and P.

(9) UltraTherm 805 supports a maximum design temperature of 850 °F (454 °C). Design temperature rating is for non-continuous use with a cumulative exposure time less of than 12 hours. Continuous use temperature is rated to 770 °F (410 °C).

(10) This is a food grade fill fluid.

(11) Not suitable for vacuum applications.

### Thermal Range Expander temperature operating range



- .... Silicone 704
  - Silicone 705
  - UltraTherm 805
- A. Ambient temperature (°C)  
 B. Process temperature (°C)

### Humidity limits

0–100 percent relative humidity

### Turn-on time

When power is applied to the transmitter during startup, performance will be within specifications per the time period described below:

**Note**

Does not apply to wireless option code X.

For option code F, device will communicate on a segment in less than 20 seconds.

Transmitter	Turn-on time (typical)
3051S, 3051SF_D, 3051SAL_C	2 seconds
Diagnostics	5 seconds
3051SMV, 3051SF_1-7	5 seconds
3051S ERS System	6 seconds

## Volumetric displacement

Less than 0.005 in<sup>3</sup> (0,08 cm<sup>3</sup>)

## Damping

### Note

Does not apply to wireless option code X.

Analog output response time to a step change is user-selectable from 0 to 60 seconds for one time constant. For Rosemount 3051SMV, 3051SF\_1-7, each variable can be individually adjusted. Software damping is in addition to sensor module response time.

## Failure mode alarm

### 4–20 mA HART® (output option code A)

If self-diagnostics detect a gross transmitter failure, the analog signal will be driven offscale to alert the user. Rosemount standard (default), NAMUR, and custom alarm levels are available (see [Alarm configuration](#)).

High or low alarm signal is software-selectable or hardware-selectable via the optional switch (option D1).

### Alarm configuration

Configuration	High alarm	Low alarm
Default	≥ 21.75 mA	≤ 3.75 mA
NAMUR compliant <sup>(1)</sup>	≥ 22.5 mA	≤ 3.6 mA
Custom levels <sup>(2)(3)</sup>	20.2 - 23.0 mA	3.4 - 3.8 mA

(1) Analog output levels are compliant with NAMUR recommendation NE 43, see option codes C4 or C5.

(2) Low alarm must be 0.1 mA less than low saturation and high alarm must be 0.1 mA greater than high saturation.

(3) For Rosemount 3051SMV and option code DA2, low alarm custom values are 3.57 - 3.8 mA.

## Physical specifications

### Material selection

Emerson provides a variety of Rosemount products with various product options and configurations including materials of construction that can be expected to perform well in a wide range of applications. The Rosemount product information presented is intended as a guide for the purchaser to make an appropriate selection for the application. It is the purchaser's sole responsibility to make a careful analysis of all process parameters (such as all chemical components, temperature, pressure, flow rate, abrasives, contaminants, etc.), when specifying product, materials, options, and components for the particular application. Emerson is not in a position to evaluate or guarantee the compatibility of the process fluid or other process parameters with the product, options, configuration or materials of construction selected.

### Electrical connections

½–14 NPT, G½, and M20 × 1½ conduit. HART® interface connections fixed to terminal block for Output code A and X.

### Process connections

Coplanar sensor module (Rosemount 3051S_C, 3051SMV, 3051SF, 3051SAM__G or A)	
Standard	¼–18 NPT on 2½-in. centers
Flange Adapters	½–14 NPT and RC½ on 2-in. (50.8 mm), 2½-in. (54.0 mm), or 2¾-in. (57.2 mm) centers

<b>In-line sensor module (Rosemount 3051S_T, 3051SAM__T or E)</b>	
Standard	½–14 NPT female
F11 Code	Non-threaded instrument flange (available in SST for sensor ranges 1–4 only)
G11 Code	G½ A DIN 16288 male (available in SST for sensor ranges 1–4 only)
H11 Code	Autoclave type F-250C (Pressure relieved 916–18 gland thread; ¼ OD high pressure tube 60° cone; available in SST for sensor range 5 only)
<b>Level transmitter (Rosemount 3051SAL)</b>	
FF Seal	2-in. (DN 50), 3-in. (DN 80), or 4-in. (DN 100); ANSI Class 150, 300, 600, 900, 1500, and 2500 flange; JIS 10K, 20K, or 40K flange; PN 10/16 or PN 40 flange
PF Seal	
EF Seal	
RF Seal	1-in. (DN 25) or 1½-in. (DN 40); ANSI Class 150, 300, or 600 flange; JIS 10K, 20K, or 40K flange; PN 40 flange
RT Seal	¼–18, ½–14, ¾–14, or 1–11.5 NPT Female
FC Seal	2-in. or 3-in.; ANSI Class 150, 300, 600, 900, 1500, 2500 flange; PN 63 or PN 100 flange
RC Seal	½-in., ¾-in., 1-in., or 1½-in.; ANSI Class 150, 300, 600, 900, 1500, 2500 flange; PN 63 or PN 100 flange
SC Seal	1½-in, 2-in, or 3-in. Hygienic Tri-Clover Style Tri-Clamp
SS Seal	4-in. Hygienic Tank Spud

**Process-wetted parts**

**Process isolating diaphragms**

<b>Coplanar sensor module (3051S_C, 3051SMV)</b>	
316L SST (UNS S31603), Alloy C-276 (UNS N10276), Alloy 400 (UNS N04400), Tantalum (UNS R05440), Gold-Plated Alloy 400, Gold-plated 316L SST	
B11 Code	Low side process connection is SST
<b>In-line sensor module (3051S_T)</b>	
316L SST (UNS S31603), Alloy C-276 (UNS N10276)	
<b>Level transmitter (Rosemount 3051SAL)</b>	
FF Seal	316L SST, Alloy C-276, Tantalum
EF Seal	
RF Seal	
RT Seal	
PF Seal	
FC Seal	
RC Seal	
SC Seal	316L SST, Alloy C-276
SS Seal	



**Drain/vent valves**

316 SST, Alloy C-276, or Alloy 400/K-500 material

(Drain vent seat: Alloy 400, Drain vent stem: Alloy K-500)

---

**Note**

Alloy 400/K-500 is not available with Rosemount 3051SAL.

---

**Process flanges and flange adapters**

Plated carbon steel

SST: CF-8M (Cast 316 SST) per ASTM A743

Cast C-276: CW-12MW per ASTM A494

Cast Alloy 400: M-30C per ASTM A494

**Wetted O-rings**

Glass-filled PTFE (Graphite-filled PTFE with isolating diaphragm code 6)

**Rosemount 3051SAL mounting flange**

Zinc-cobalt plated CS or 316 SST

**Rosemount 3051SAL seal extension**

CF-3M (Cast 316L SST, material per ASTM A743) or CW-12MW (Cast C-276, material per ASTM A494)

**Non-wetted parts****Electronics housing**

Low-copper aluminum alloy or CF-8M (Cast 316 SST)

Enclosures meet NEMA® Type 4X, IP66, and IP68 [66 ft (20 m) for 168 hours] when properly installed.

---

**Note**

IP 68 not available with Wireless output.

---

**Coplanar sensor module housing**

SST: CF-3M (Cast 316L SST)

**Bolts**

Plated carbon steel per ASTM A449, Type 1

Austenitic 316 SST per ASTM F593

ASTM A453, Class D, Grade 660 SST

ASTM A193, Grade B7M alloy steel

ASTM A193, Class 2, Grade B8M SST

Alloy K-500

**Sensor module fill fluid**

Silicone is standard.

Inert is available as option code (L1).

---

**Note**

Inert is not available with Rosemount 3051S\_CA.

---

Inert for in-line series uses Fluorinert™ FC-43.

Inert for coplanar series uses Halocarbon.

**Seal fill fluid (liquid level only)**

Rosemount 3051SAL: Silicone 200, Tri-Therm 300, Silicone 704, Silicone 705, UltraTherm 805, inert, SYL THERM XLT, Neobee M-20, glycerin and water, propylene glycol and water.

**Paint for aluminum housing**

Polyurethane

**Cover O-rings**

Buna-N

**Wireless antenna**

External antenna (WK/WM): PBT/PC integrated omni-directional antenna

Remote antenna (WN): Fiberglass omni-directional antenna

**Power module**

Field replaceable, keyed connection eliminates the risk of incorrect installation, Intrinsically Safe Lithium-thionyl chloride Power module with PBT enclosure

**Shipping weights**

**Table 29: Sensor Modules**

<b>Coplanar sensor module<sup>(1)</sup></b>	
3.1 lb. (1.4 kg)	
<b>In-line sensor module</b>	
1.4 lb. (0.6 kg)	

(1) Flange and bolts not included.

**Table 30: Transmitters**

Fully functional transmitter with module, terminal bock, standard covers, and connector board, if applicable.

<b>Transmitter with coplanar sensor module (3051S_C, 3051SMV, 3051SAM__G or A)</b>	
Junction Box housing, SST flange	6.3 lb. (2.8 kg)
Plantweb™ housing, SST flange	6.7 lb. (3.1 kg)
Wireless Plantweb housing, SST flange	7.3 lb. (3.3 kg)
<b>Transmitter with in-line sensor module (3051S_T, 3051SAM__T or E)</b>	
Junction box housing	3.2 lb. (1.4 kg)
Plantweb housing	3.7 lb. (1.7 kg)
Wireless Plantweb housing	4.2 lb. (1.9 kg)

**Table 31: Transmitter Options**

Option code	Option	Add lb. (kg)
1J, 1K, 1L	SST Plantweb™ housing	3.5 (1.6)

**Table 31: Transmitter Options (continued)**

Option code	Option	Add lb. (kg)
2J	SST junction box housing	3.4 (1.5)
7J	SST quick connect	0.4 (0.2)
2A, 2B, 2C	Aluminum junction box housing	1.1 (0.5)
1A, 1B, 1C	Aluminum Plantweb housing	1.1 (0.5)
M5 <sup>(1)</sup>	LCD display for aluminum Plantweb housing	0.8 (0.4)
	LCD display for SST Plantweb housing	1.6 (0.7)
B4	SST mounting bracket for coplanar flange	1.2 (0.5)
B1, B2, B3	Mounting bracket for traditional flange	1.7 (0.8)
B7, B8, B9	Mounting bracket for traditional flange with SST bolts	1.7 (0.8)
BA, BC	SST bracket for traditional flange	1.6 (0.7)
B4	SST mounting bracket for in-line	1.3 (0.6)
F12, F22 <sup>(2)</sup>	SST traditional flange with SST drain vents	3.2 (1.5)
F13, F23 <sup>(2)</sup>	Cast C-276 traditional flange with Alloy C-276 drain vents	3.6 (1.6)
E12, E22 <sup>(2)</sup>	SST coplanar Flange with SST drain vents	1.9 (0.9)
F14, F24 <sup>(2)</sup>	Cast Alloy 400 traditional flange with Alloy 400/K-500 drain vents	3.6 (1.6)
F15, F25 <sup>(2)</sup>	SST traditional flange with Alloy C-276 drain vents	3.2 (1.5)
G21	Level flange (3-in., Class 150)	12.6 (5.7)
G22	Level flange (3-in., Class 300)	15.9 (7.2)
G11	Level flange (2-in., Class 150)	6.8 (3.1)
G12	Level flange (2-in., Class 300)	8.2 (3.7)
G31	DIN level flange, SST, DN 50, PN 40	7.8 (3.5)
G41	DIN level flange, SST, DN 80, PN 40	13.0 (5.9)

(1) Includes LCD display and display cover.

(2) Includes mounting bolts.

**Table 32: Transmitter Components**

Item	Weight in lb. (kg)
Aluminum standard cover	0.4 (0.2)
SST standard cover	1.3 (0.6)
Aluminum display cover	0.7 (0.3)
SST display cover	1.5 (0.7)
Wireless extended cover	0.7 (0.3)
LCD display <sup>(1)</sup>	0.1 (0.04)
Junction box terminal block	0.2 (0.1)
Plantweb terminal block	0.2 (0.1)
Power module	0.5 (0.2)

(1) Display only.

**Table 33: Rosemount 3051SAL without SuperModule Platform, Housing, or Transmitter Options**

Flange	Flush lb. (kg)	2-in. Ext. lb. (kg)	4-in. Ext. lb. (kg)	6-in. Ext. lb. (kg)
2-in., Class 150	9.5 (4.3)	N/A	N/A	N/A
3-in., Class 150	15.7 (7.1)	16.4 (7.4)	17.6 (8.0)	18.9 (8.6)
4-in., Class 150	21.2 (9.6)	20.9 (9.5)	22.1 (10.0)	23.4 (10.6)
2-in., Class 300	11.3 (5.1)	N/A	N/A	N/A
3-in., Class 300	19.6 (8.9)	20.3 (9.2)	21.5 (9.8)	22.8 (10.3)
4-in., Class 300	30.4 (13.8)	30.3 (13.7)	31.5 (14.3)	32.8 (14.9)
2-in., Class 600	12.8 (5.8)	N/A	N/A	N/A
3-in., Class 600	22.1 (10.0)	22.8 (10.3)	24.0 (10.9)	25.3 (11.5)
DN 50/PN 40	11.3 (5.1)	N/A	N/A	N/A
DN 80/PN 40	16.0 (7.3)	16.7 (7.6)	17.9 (8.1)	19.2 (8.7)
DN 100/PN 10/16	11.2 (5.1)	11.9 (5.4)	13.1 (5.9)	14.4 (6.5)
DN 100/PN 40	12.6 (5.7)	13.3 (6.0)	14.5 (6.6)	15.8 (7.1)

# Product certifications

## Rosemount 3051S/3051SFx/3051S-ERS

Rev 3.2

### European Directive Information

A copy of the EU Declaration of Conformity can be found at the end of the Quick Start Guide. The most recent revision of the EU Declaration of Conformity can be found at [Emerson.com/Rosemount](http://Emerson.com/Rosemount).

### Ordinary Location Certification

As standard, the transmitter has been examined and tested to determine that the design meets the basic electrical, mechanical, and fire protection requirements by a nationally recognized test laboratory (NRTL) as accredited by the Federal Occupational Safety and Health Administration (OSHA).

### Installing Equipment in North America

The US National Electrical Code® (NEC) and the Canadian Electrical Code (CEC) permit the use of Division marked equipment in Zones and Zone marked equipment in Divisions. The markings must be suitable for the area classification, gas, and temperature class. This information is clearly defined in the respective codes.

## USA

### E5 US Explosionproof (XP) and Dust-Ignitionproof (DIP)

**Certificate** FM16US0090

**Standards** FM Class 3600 – 2018, FM Class 3615 – 2018, FM Class 3616 – 2011, FM Class 3810 – 2018, ANSI/NEMA 250 – 2003

**Markings** XP CL I, DIV 1, GP B, C, D; DIP CL II, DIV 1, GP E, F, G; CL III; T5(-50 °C ≤ T<sub>a</sub> ≤ +85 °C); Factory Sealed; Type 4X

### I5 US Intrinsic Safety (IS) and Nonincendive (NI)

**Certificate** FM16US0089X

**Standards** FM Class 3600:2018, FM Class 3610:2010, FM Class 3611:2004, FM Class 3616:2011, FM Class 3810:2018, ANSI/ISA-60079-0:2013, ANSI/ISA-60079-11:2013, ANSI/ISA-61010-1:2004, NEMA 250:1991 (3051SFA only) or NEMA 250:2003

**Markings** IS CL I, DIV 1, GP A, B, C, D; CL II, DIV 1, GP E, F, G; Class III; Class 1, Zone 0 AEx ia IIC T4; NI CL 1, DIV 2, GP A, B, C, D; T4 (-50 °C ≤ T<sub>a</sub> ≤ +70 °C) [HART]; T4 (-50 °C ≤ T<sub>a</sub> ≤ +60 °C) [Fieldbus]; when connected per Rosemount drawing 03151-1006; Type 4X

### Special Condition for Safe Use (X):

1. The Model 3051S/3051S-ERS Pressure Transmitter contains aluminum and is considered to constitute a potential risk of ignition by impact or friction. Care must be taken into account during installation and use to prevent impact and friction.

### Note

Transmitters marked with NI CL 1, DIV 2 can be installed in Division 2 locations using general Division 2 wiring methods or Nonincendive Field Wiring (NIFW). See Drawing 03151-1006.

### US Intrinsic Safety (IS) and Nonincendive (NI)

**Certificate** 1143113

**Standards** FM Class 3600:2011, FM Class 3610:2010, FM Class 3611:2004, FM Class 3810:2005, UL50E (1<sup>st</sup> Ed.)

**Markings** IS Class I/II/III, Division 1, Groups A, B, C, D, T4/ E, F, and G T135°C; Class I, Zone 0 AEx ia IIC T4 Ga; T4(-50 °C ≤ T<sub>a</sub> ≤ +70 °C) [HART]; T4(-50 °C ≤ T<sub>a</sub> ≤ +60 °C) [Fieldbus];

when connected per Rosemount drawing 03151- 1016; Type 4X

### IE US FISCO

**Certificate** FM16US0089X

**Standards** FM Class 3600 – 2011, FM Class 3610 – 2010, FM Class 3611 – 2004, FM Class 3810 – 2005, NEMA 250 – 2003

**Markings** IS CL I, DIV 1, GP A, B, C, D; T4 ( $-50\text{ °C} \leq T_a \leq +60\text{ °C}$ ); when connected per Rosemount drawing 03151-1006; Type 4X

### Special Condition for Safe Use (X):

The Rosemount 3051S/3051S-ERS Pressure Transmitter contains aluminum and is considered to constitute a potential risk of ignition by impact or friction. Care must be taken into account during installation and use to prevent impact and friction.

US FISCO

**Certificate** 1143113

**Standards** FM Class 3600:2011, FM Class 3610:2010, FM Class 3611:2004, FM Class 3810:2005, UL50E (1<sup>st</sup> Ed.)

**Markings** : IS Class I/II/III, Division 1, Groups A, B, C, D, T4/ E, F, and G T135°C; Class I, Zone 0 AEx ia IIC T4 Ga; T4( $-50\text{ °C} \leq T_a \leq +70\text{ °C}$ ) [HART]; T4( $-50\text{ °C} \leq T_a \leq +60\text{ °C}$ ) [Fieldbus]; when connected per Rosemount drawing 03151-1016; Type 4X

## Canada

### E6 Canada Explosionproof, Dust-Ignitionproof, and Division 2

**Certificate** 1143113

**Standards** CAN/CSA C22.2 No. 0-10, CSA Std C22.2 No. 25-1966, CSA Std C22.2 No. 30-M1986, CAN/CSA C22.2 No. 94-M91, CSA Std C22.2 No. 142-M1987, CSA Std C22.2 No. 213-M1987, ANSI/ISA 12.27.01-2003, CSA Std C22.2 No. 60529:05

**Markings** Explosionproof Class I, Division 1, Groups B, C, D; Dust-Ignitionproof Class II, Division 1, Groups E, F, G; Class III; suitable for Class I, Zone 1, Group IIB+H2, T5; suitable for Class I, Division 2, Groups A, B, C, D; suitable for Class I, Zone 2, Group IIC, T5; when connected per Rosemount drawing 03151-1013; Type 4X

### I6 Canada Intrinsically Safe

**Certificate** 1143113

**Standards** CAN/CSA C22.2 No. 0-10, CSA Std C22.2 No. 30-M1986, CAN/CSA C22.2 No. 94-M91, CSA Std C22.2 No. 142-M1987, CSA Std C22.2 No. 157-92, ANSI/ISA 12.27.01-2003, CSA Std C22.2 No. 60529:05

**Markings** Intrinsically Safe Class I, Division 1; Groups A, B, C, D; suitable for Class 1, Zone 0, IIC, T3C; when connected per Rosemount drawing 03151-1016 [3051S] 03151-1313 [ERS]; Type 4X

### IF Canada FISCO

**Certificate** 1143113

**Standards** CAN/CSA C22.2 No. 0-10, CSA Std C22.2 No. 30-M1986, CAN/CSA C22.2 No. 94-M91, CSA Std C22.2 No. 142-M1987, CSA Std C22.2 No. 157-92, ANSI/ISA 12.27.01-2003, CSA Std C22.2 No. 60529:05


**Markings** FISCO Intrinsically Safe Class I, Division 1; Groups A, B, C, D; suitable for Class 1, Zone 0, IIC, T3C; when connected per Rosemount drawing 03151-1016 [3051S] 03151-1313 [ERS]; Type 4X

## Europe

### E1 ATEX Flameproof

**Certificate** KEMA 00ATEX2143X

**Standards** EN IEC 60079-0:2018, EN 60079-1:2014, EN 60079-26:2015

**Markings**  II 1/2 G Ex db IIC T6...T4 Ga/Gb, T6 (-60 °C ≤ T<sub>a</sub> ≤ +70 °C), T5/T4 (-60 °C ≤ T<sub>a</sub> ≤ +80 °C)

**Table 34: Process Temperature**

Temperature class	Process temperature
T6	-60 °C to +70 °C
T5	-60 °C to +80 °C
T4	-60 °C to +120 °C


### Special Conditions for Safe Use (X):

1. This device contains a thin wall diaphragm less than 1 mm thickness that forms a boundary between Category 1 (process connection) and Category 2 (all other parts of the equipment). The model code and datasheet are to be consulted for details of the diaphragm material. Installation, maintenance and use shall take into account the environmental conditions to which the diaphragm will be subjected. The manufacturer's instructions for installation and maintenance shall be followed in detail to assure safety during its expected lifetime.
2. Flameproof joints are not intended for repair.
3. Non-standard paint options may cause risk from electrostatic discharge. Avoid installations that could cause electrostatic build-up on painted surfaces, and only clean the painted surfaces with a damp cloth. If paint is ordered through a special option code, contact the manufacturer for more information.
4. Appropriate cable, glands and plugs need to be suitable for a temperature of 5 °C greater than maximum specified temperature for location where installed.

### I1 ATEX Intrinsic Safety

**Certificate** BAS01ATEX1303X

**Standards** EN IEC 60079-0: 2018, EN 60079-11: 2012

**Markings**  II 1 G Ex ia IIC T4 Ga, T4 (-60 °C ≤ T<sub>a</sub> ≤ +70 °C)

**Table 35: Input Parameters**

	U <sub>i</sub>	I <sub>i</sub>	P <sub>i</sub>	C <sub>i</sub>	L <sub>i</sub>
SuperModule	30 V	300 mA	1.0 W	30 nF	0
3051S...A; 3051SF...A; 3051SAL...C	30 V	300 mA	1.0 W	12 nF	0
3051S...F; 3051SF...F	30 V	300 mA	1.3 W	0	0
3051S ...A...M7, M8, or M9; 3051SF ...A...M7, M8, or M9; 3051SAL...C... M7, M8, or M9	30 V	300 mA	1.0 W	12 nF	60 μH
3051SAL or 3051SAM	30 V	300 mA	1.0 W	12 nF	33 μH
3051SAL...M7, M8, or M9 3051SAM...M7, M8, or M9	30 V	300 mA	1.0 W	12 nF	93 μH
RTD Option for 3051SF	5 V	500 mA	0.63 W	N/A	N/A

**Special Conditions for Safe Use (X):**

1. The Model 3051S Transmitters fitted with transient protection are not capable of withstanding the 500 V test as defined in Clause 6.3.13 f EN 60079-11:2012. This must be taken into account during installation.
2. The terminal pins of the Model 3051S SuperModule must be provided with a degree of protection of at least IP20 in accordance with IEC/EN 60529.
3. The Model 3051S enclosure may be made of aluminum alloy and given a protective polyurethane paint finish; however, care should be taken to protect it from impact or abrasion if located in a zone 0 area.

**IA ATEX FISCO**

<b>Certificate</b>	BAS01ATEX1303X
<b>Standards</b>	EN IEC 60079-0: 2018, EN 60079-11: 2012
<b>Markings</b>	⊕ II 1 G Ex ia IIC T4 Ga, T4 (-60 °C ≤ T <sub>a</sub> ≤ +70 °C)

**Table 36: Input Parameters**

Parameter	FISCO
Voltage U <sub>i</sub>	17.5 V
Current I <sub>i</sub>	380 mA
Power P <sub>i</sub>	5.32 W
Capacitance C <sub>i</sub>	0
Inductance L <sub>i</sub>	0

**Special Conditions for Safe Use (X):**

1. The Model 3051S Transmitters fitted with transient protection are not capable of withstanding the 500 V test as defined in Clause 6.3.13 of EN 60079-11:2012. This must be taken into account during installation.
2. The terminal pins of the Model 3051S SuperModule must be provided with a degree of protection of at least IP20 in accordance with IEC/EN 60529.
3. The Model 3051S enclosure may be made of aluminum alloy and given a protective polyurethane paint finish; however, care should be taken to protect it from impact or abrasion if located in a zone 0 area.

**ND ATEX Dust**

<b>Certificate</b>	BAS01ATEX1374X
<b>Standards</b>	EN 60079-0: 2012+A11:2013, EN 60079-31: 2009
<b>Markings</b>	⊕ II 1 D Ex ta IIIC T105 °C T <sub>500</sub> 95 °C Da, (-20 °C ≤ T <sub>a</sub> ≤ +85 °C), V <sub>max</sub> = 42.4 V

**Special Conditions for Safe Use (X):**

1. Cable entries must be used which maintain the ingress protection of the enclosure to at least IP66.
2. Unused cable entries must be filled with suitable blanking plugs which maintain the ingress protection of the enclosure to at least IP66.
3. Cable entries and blanking plugs must be suitable for the ambient temperature range of the apparatus and capable of withstanding a 7J impact test.
4. The SuperModule(s) must be securely screwed in place to maintain the ingress protection of the enclosure(s).

**N1 ATEX Type n**

<b>Certificate</b>	BAS01ATEX3304X
--------------------	----------------



**Standards** EN IEC 60079-0: 2018, EN 60079-15: 2010  
**Markings** Ⓢ II 3 G Ex nA IIC T5 Gc, (-40 °C ≤ T<sub>a</sub> ≤ +85 °C), V<sub>max</sub> = 45 V

**Special Condition for Safe Use (X):**

1. The equipment is not capable of withstanding the 500 V insulation test required by clause 6.5 of EN 60079-15:2010. This must be taken into account when installing the equipment.

**Note**

RTD Assembly is not included with the 3051SFx Type n Approval.

**International**

**E7 IECEx Flameproof and Dust**

**Certificate** IECEx KEM 08.0010X (Flameproof)  
**Standards** IEC 60079-0:2017, IEC 60079-1:2014, IEC 60079-26:2014  
**Markings** Ex db IIC T6...T4 Ga/Gb, T6 (-60 °C ≤ T<sub>a</sub> ≤ +70 °C), T5/T4 (-60 °C ≤ T<sub>a</sub> ≤ +80 °C)

**Table 37: Process Temperature**

Temperature class	Process temperature
T6	-60 °C to +70 °C
T5	-60 °C to +80 °C
T4	-60 °C to +120 °C

**Special Conditions for Safe Use (X):**

1. This device contains a thin wall diaphragm less than 1 mm thickness that forms a boundary between EPL Ga (process connection) and EPL Gb (all other parts of the equipment). The model code and datasheet are to be consulted for details of the diaphragm material. Installation, maintenance and use shall take into account the environmental conditions to which the diaphragm will be subjected. The manufacturer's instructions for installation and maintenance shall be followed in detail to assure safety during its expected lifetime.
2. Flameproof joints are not intended for repair.
3. Non-standard paint options may cause risk from electrostatic discharge. Avoid installations that could cause electrostatic buildup on painted surfaces, and only clean the painted surfaces with a damp cloth. If paint is ordered through a special option code, contact the manufacturer for more information.
4. Appropriate cable, glands and plugs need to be suitable for a temperature of 5 °C greater than maximum specified temperature for location where installed.

**Certificate** IECEx BAS 09.0014X (Dust)  
**Standards** IEC 60079-0:2011, IEC 60079-31:2008  
**Markings** Ex ta IIIC T105 °C T50095 °C Da, (-20 °C ≤ T<sub>a</sub> ≤ +85 °C), V<sub>max</sub> = 42.4 V

**Special Conditions for Safe Use (X):**

1. Cable entries must be used which maintain the ingress protection of the enclosure to at least IP66.
2. Unused cable entries must be filled with suitable blanking plugs which maintain the ingress protection of the enclosure to at least IP66.
3. Cable entries and blanking plugs must be suitable for the ambient temperature range of the apparatus and capable of withstanding a 7J impact test.

4. The 3051S SuperModule must be securely screwed in place to maintain the ingress protection of the enclosure.

### I7 IECEx Intrinsic Safety

<b>Certificate</b>	IECEx BAS 04.0017X
<b>Standards</b>	IEC 60079-0: 2017, IEC 60079-11: 2011
<b>Markings</b>	Ex ia IIC T4 Ga, T4(-60 °C ≤ T <sub>a</sub> ≤ +70 °C)

**Table 38: Input Parameters**

	U <sub>i</sub>	I <sub>i</sub>	P <sub>i</sub>	C <sub>i</sub>	L <sub>i</sub>
SuperModule	30 V	300 mA	1.0 W	30 nF	0
3051S...A; 3051SF...A; 3051SAL...C	30 V	300 mA	1.0 W	12 nF	0
3051S...F; 3051SF...F	30 V	300 mA	1.3 W	0	0
3051S ...A...M7, M8, or M9; 3051SF ...A...M7, M8, or M9; 3051SAL...C... M7, M8, or M9	30 V	300 mA	1.0 W	12 nF	60 μH
3051SAL or 3051SAM	30 V	300 mA	1.0 W	12 nF	33 μH
3051SAL...M7, M8, or M9 3051SAM...M7, M8, or M9	30 V	300 mA	1.0 W	12 nF	93 μH
RTD Option for 3051SF	5 V	500 mA	0.63 W	N/A	N/A

### Special Conditions for Safe Use (X):

1. The Model 3051S Transmitters fitted with transient protection are not capable of withstanding the 500 V test as defined in Clause 6.3.13 of EN 60079-11:2012. This must be taken into account during installation.
2. The terminal pins of the Model 3051S SuperModule must be provided with a degree of protection of at least IP20 in accordance with IEC/EN 60529.
3. The Model 3051S enclosure may be made of aluminum alloy and given a protective polyurethane paint finish; however, care should be taken to protect it from impact or abrasion if located in a zone 0 area.

### I7 IECEx Intrinsic Safety - Group I - Mining (I7 with Special A0259)

<b>Certificate</b>	IECEx TSA 14.0019X
<b>Standards</b>	IEC 60079-0: 2011, IEC 60079-11: 2011
<b>Markings</b>	Ex ia I Ma (-60 °C ≤ T <sub>a</sub> ≤ +70 °C)

**Table 39: Input Parameters**

	U <sub>i</sub>	I <sub>i</sub>	P <sub>i</sub>	C <sub>i</sub>	L <sub>i</sub>
SuperModule	30 V	300 mA	1.0 W	30 nF	0
3051S...A; 3051SF...A; 3051SAL...C	30 V	300 mA	1.0 W	12 nF	0
3051S...F; 3051SF...F	30 V	300 mA	1.3 W	0	0
3051S ...A...M7, M8, or M9; 3051SF ...A...M7, M8, or M9; 3051SAL...C... M7, M8, or M9	30 V	300 mA	1.0 W	12 nF	60 μH
3051SAL or 3051SAM	30 V	300 mA	1.0 W	12 nF	33 μH
3051SAL...M7, M8, or M9 3051SAM...M7, M8, or M9	30 V	300 mA	1.0 W	12 nF	93 μH

**Table 39: Input Parameters (continued)**

	<b>U<sub>i</sub></b>	<b>I<sub>i</sub></b>	<b>P<sub>i</sub></b>	<b>C<sub>i</sub></b>	<b>L<sub>i</sub></b>
RTD Option for 3051SF	5 V	500 mA	0.63 W	N/A	N/A

**Special Conditions for Safe Use (X):**

1. If the apparatus is fitted with optional 90 V transient suppressor, it is not capable of withstanding the 500 V insulation test required by Clause 6.3.13 of IEC60079-11. This must be taken into account when installing the apparatus.
2. It is a condition of safe use that the above input parameters shall be taken into account during installation.
3. It is a condition of manufacture that only the apparatus fitted with housing, covers and sensor module housing made out of stainless steel are used in Group I applications.

**IG IECEx FISCO**

**Certificate** IECEx BAS 04.0017X  
**Standards** IEC 60079-0: 2017, IEC 60079-11: 2011  
**Markings** Ex ia IIC T4 Ga, T4(-60 °C ≤ T<sub>a</sub> ≤ +70 °C)

**Table 40: Input Parameters**

<b>Parameter</b>	<b>FISCO</b>
Voltage U <sub>i</sub>	17.5 V
Current I <sub>i</sub>	380 mA
Power P <sub>i</sub>	5.32 W
Capacitance C <sub>i</sub>	0
Inductance L <sub>i</sub>	0

**Special Conditions for Safe Use (X):**

1. The Model 3051S Transmitters fitted with transient protection are not capable of withstanding the 500 V test as defined in Clause 6.3.13 of EN 60079-11:2012. This must be taken into account during installation.
2. The terminal pins of the Model 3051S SuperModule must be provided with a degree of protection of at least IP20 in accordance with IEC/EN 60529.
3. The Model 3051S enclosure may be made of aluminum alloy and given a protective polyurethane paint finish; however, care should be taken to protect it from impact or abrasion if located in a zone 0 area.

**IG IECEx Intrinsic Safety - Group I - Mining (IG with Special A0259)**

**Certificate** IECEx TSA 14.0019X  
**Standards** IEC 60079-0: 2011, IEC 60079-11: 2011  
**Markings** FISCO FIELD DEVICE Ex ia I Ma , (-60 °C ≤ T<sub>a</sub> ≤ +70 °C)

**Table 41: Input Parameters**

<b>Parameter</b>	<b>FISCO</b>
Voltage U <sub>i</sub>	17.5 V
Current I <sub>i</sub>	380 mA
Power P <sub>i</sub>	5.32 W
Capacitance C <sub>i</sub>	0

**Table 41: Input Parameters (continued)**

Inductance $L_i$	0
------------------	---

**Special Conditions for Safe Use (X):**

1. If the apparatus is fitted with optional 90 V transient suppressor, it is not capable of withstanding the 500 V insulation test required by Clause 6.3.13 of IEC60079-11. This must be taken into account when installing the apparatus.
2. It is a condition of safe use that the above input parameters shall be taken into account during installation.
3. It is a condition of manufacture that only the apparatus fitted with housing, covers and sensor module housing made out of stainless steel are used in Group I applications.

**N7 IECEx Type n**

<b>Certificate</b>	IECEx BAS 04.0018X
<b>Standards</b>	IEC 60079-0: 2017, IEC 60079-15: 2010
<b>Markings</b>	Ex nA IIC T5 Gc, ( $-40\text{ °C} \leq T_a \leq +85\text{ °C}$ )

**Special Condition for Safe Use (X):**

The equipment is not capable of withstanding the 500 V insulation test required by clause 6.5 of EN 60079-15:2010. This must be taken into account when installing the equipment.

**Brazil****E2 INMETRO Flameproof**

<b>Certificate</b>	UL-BR 15.0393X
<b>Standards</b>	ABNT NBR IEC 60079-0:2008 + Corrigendum 1:2011, ABNT NBR IEC 60079-1:2009 + Corrigendum 1:2011, ABNT NBR IEC 60079-26:2008 + Corrigendum 1: 2008
<b>Markings</b>	Ex db IIC T* Ga/Gb, T6( $-60\text{ °C} \leq T_a \leq +70\text{ °C}$ ), T5/T4( $-60\text{ °C} \leq T_a \leq +80\text{ °C}$ ), IP66

**Special Conditions for Safe Use (X):**

1. The device contains a thin wall diaphragm less than 1 mm thick that forms a boundary between zone 0 (process connection) and zone 1 (all other parts of the equipment). The model code and datasheet are to be consulted for details of the diaphragm material. Installation, maintenance, and use shall take into account the environmental conditions to which the diaphragm will be subjected. The manufacturer's instructions for maintenance shall be followed in detail to assure safety during its expected lifetime.
2. Flameproof joints are not intended for repair.
3. Non-standard paint options may cause risk from electrostatic discharge. Avoid installations that could cause electrostatic buildup on painted surfaces, and only clean the painted surfaces with a damp cloth. If paint is ordered through a special option code, contact the manufacturer for more information.

**I2/IB INMETRO Intrinsic Safety/FISCO**

<b>Certificate</b>	UL-BR 15.0392X
<b>Standards</b>	ABNT NBR IEC 60079-0:2013, ABNT NBR IEC 60079-11:2013
<b>Markings</b>	Ex ia IIC T4 Ga ( $-60\text{ °C} \leq T_a \leq +70\text{ °C}$ ), IP66

**Special Conditions for Safe Use (X):**

1. The surface resistivity of the antenna is greater than 1 GΩ. To avoid electrostatic charge buildup, it must not be rubbed or cleaned with solvents or a dry cloth.

2. The Model 701PBKFF Power Module may be replaced in a hazardous area. The Power Module has a surface resistivity greater than 1 GΩ and must be properly installed in the wireless device enclosure. Care must be taken during transportation to and from the point of installation to prevent electrostatic charge buildup.
3. The 3051S enclosure may be made of aluminium alloy and given a protective polyurethane paint finish; however, care should be taken to protect it from impact or abrasion if located in areas that requires EPL Ga.

**Table 42: Input Parameters**

	U <sub>i</sub>	I <sub>i</sub>	P <sub>i</sub>	C <sub>i</sub>	L <sub>i</sub>
SuperModule	30 V	300 mA	1.0 W	30 nF	0
3051S...A; 3051SF...A; 3051SAL...C	30 V	300 mA	1.0 W	12 nF	0
3051S...F; 3051SF...F	30 V	300 mA	1.3 W	0	0
3051S...F...IB; 3051SF...F...IB	17.5 V	380mA	5.32 W	0	0
3051S ...A...M7, M8, or M9; 3051SF ...A...M7, M8, or M9; 3051SAL...C... M7, M8, or M9	30 V	300 mA	1.0 W	12 nF	60 μH
3051SAL or 3051SAM	30 V	300 mA	1.0 W	12 nF	33 μH
3051SAL... M7, M8, or M9 3051SAM... M7, M8, or M9	30 V	300 mA	1.0 W	12 nF	93 μH
RTD Option for 3051SF	5 V	500 mA	0.63 W	N/A	N/A

## China

### E3 China Flameproof and Dust Ignition-proof

**Certificate** 3051S: GYJ16.1249X  
 3051SFx: GYJ16.1466X  
 3051S-ERS: GYJ20.1489X

**Standards** 3051S: GB3836.1-2010, GB3836.2-2010, GB3836.20-2010, GB12476.1-2013, GB12476.5-2013  
 3051SFx: GB3836.1-2010, GB3836.2-2010, GB3836.20-2010, GB12476.1-2013, GB 12476.5-2013  
 3051S-ERS: GB3836.1-2010, GB3836.2-2010, GB3836.20-2010

**Markings** 3051S: Ex d IIC T6...T4; Ex tD A20 T105 °C T<sub>500</sub> 95 °C; IP66  
 3051SFx: Ex d IIC T4~T6 Ga/Gb; Ex tD A20 IP66 T105 °C T<sub>500</sub> 95 °C; IP66  
 3051S-ERS: Ex d IIC T4~T6 Ga/Gb

#### 产品安全使用特殊条件

- 证书编号后缀“X”表明产品具有安全使用特殊条件: 涉及隔爆接合面的维修须联系产品制造商.
- 产品使用注意事项
  1. 用于爆炸性气体环境中, 产品使用环境温度与温度组别和介质温度的关系为:

温度组别	环境温度	过程温度
T6	-60 °C ≤ Ta ≤ +70 °C	-60 °C ≤ Ta ≤ +70 °C
T5	-60 °C ≤ Ta ≤ +80 °C	-60 °C ≤ Ta ≤ +80 °C
T4	-60 °C ≤ Ta ≤ +80 °C	-60 °C ≤ Ta ≤ +120 °C

2. 用于爆炸性粉尘环境中, 产品使用环境温度为: -20 °C ≤ Ta ≤ +85 °C

3. 产品外壳设有接地端子, 用户在使用时应可靠接地.
4. 安装现场应不存在对产品外壳有腐蚀作用的有害气体.
5. 现场安装时, 电缆引入口须选用国家指定的防爆检验机构按检验认可, 具有 Ex dIIC, Ex tD A20 IP66 防爆等级的电缆引入装置或堵封件, 冗余电缆引入口须用堵封件有效密封.
6. 用于爆炸性气体环境中, 现场安装, 使用和维护必须严格遵守“断电后开盖!”的警告语. 用于爆炸性粉尘环境中, 现场安装, 使用和维护必须严格遵守“爆炸性粉尘场所严禁开盖!”的警告语.
7. 用于爆炸性粉尘环境中, 产品外壳表面需保持清洁, 以防粉尘堆积, 但严禁用压缩空气吹扫.
8. 用户不得自行更换该产品的零部件, 应会同产品制造商共同解决运行中出现的故障, 以杜绝损坏现象的发生.
9. 产品的安装, 使用和维护应同时遵守产品使用说明书, GB3836.13-2013“爆炸性环境 第 13 部分: 设备的修理, 检修, 修复和改造”, GB3836.15-2000“爆炸性气体环境用电气设备 第 15 部分: 危险场所电气安装 (煤矿除外)”, GB3836.16-2006“爆炸性气体环境用电气设备 第 16 部分: 电气装置的检查和维护 (煤矿除外)”, GB50257-2014“电气装置安装工程爆炸和火灾危险环境电力装置施工及验收规范”和 GB15577-2007“粉尘防爆安全规程”, GB12476.2-2010“可燃性粉尘环境用电气设备 第 2 部分: 选型和安装”的有关规定.

### 13 China Intrinsic Safety

<b>Certificate</b>	3051S: GYJ16.1250X [Mfg USA, China, Singapore] 3051SFx: GYJ16.1465X [Mfg USA, China, Singapore] 3051S-ERS: GYJ16.1248X [Mfg USA, China, Singapore]
<b>Standards</b>	3051S: GB3836.1-2010, GB3836.4-2010, GB3836.20-2010 3051SFx: GB3836.1/4-2010, GB3836.20-2010, GB12476.1-2013, GB12476.5-2013 3051S-ERS: GB3836.1-2010, GB3836.4-2010, GB3836.20-2010
<b>Markings</b>	3051S: Ex ia IIC T4 Ga 3051SFx: Ex ia IIC T4 Ga, Ex tD A20 IP66 T105 °CT <sub>500</sub> 95 °C 3051S-ERS: Ex ia IIC T4 Ga

#### 产品安全使用特殊条件:

- 证书编号后缀“X”表明产品具有安全使用特殊条件:
  1. 产品外壳含有轻金属, 用于 0 区时需注意防止由于冲击或摩擦产生的点燃危险.
  2. 当选择 T1 瞬态抑制端子时, 此设备不能承受 GB3836.4-2010 标准中第 6.3.12 条规定的 500V 交流有效值试验电压的介电强度试验.
  3. Transmitter output 为 X 时, 天线表面电阻大于 1 GΩ, 为了避免静电积聚, 不允许用溶剂或者干布擦拭; 电源模块表面电阻大于 1 GΩ, 如果在危险区域更换, 则需要避免静电积聚; 只能使用由原制造厂提供的 P/N 753-9220-XXXX 电池.
- 产品使用注意事项:
  1. 产品使用环境温度为:
    - 用于爆炸性气体环境中, 产品使用环境温度为:  $-60^{\circ}\text{C} \leq T_a \leq +70^{\circ}\text{C}$
    - 用于爆炸性粉尘环境中, 产品使用环境温度为:  $-20^{\circ}\text{C} \leq T_a \leq +85^{\circ}\text{C}$
  2. 本安电气参数:

型号	端子	最高输入电压 $U_i$ ( V )	最大输入电流 $I_i$ ( mA )	最大输入功率 $P_i$ ( W )	最大内部等效参数	
					$C_i$ ( nF )	$L_i$ ( $\mu\text{H}$ )
3051SAL_C	+, -, CAN	30	300	1	12	0
3051SAL_C... M7/M8/M9	+, -	30	300	1	12	60
3051SAL, 3051SAM	+, -, CAN	30	300	1	12	33

型号	端子	最高输入电压 $U_i$ ( V )	最大输入电流 $I_i$ ( mA )	最大输入功率 $P_i$ ( W )	最大内部等效参数	
					$C_i$ ( nF )	$L_i$ ( $\mu$ H )
3051SAL... M7/M8/M9 3051SAM... M7/M8/M9	+, -	30	300	1	12	93

变送器输出	端子	最高输入电压 $U_i$ ( V )	最大输入电流 $I_i$ ( mA )	最大输入功率 $P_i$ ( W )	最大内部等效参数	
					$C_i$ ( nF )	$L_i$ ( $\mu$ H )
SuperModule	+, -, CAN	30	300	1	30	0
A	+, -	30	300	1	12	0
A 配 M7, M8 或 M9 显示	+, -, CAN	30	300	1	12	60
F	+, -	30	300	1.3	0	0
FISCO	+, -	17.5	380	5.32	0	0
RTD 选项	-	5	500	0.63	-	-

注: 本安电气参数符合 GB3836.19-2010 对 FISCO 现场仪表的参数要求。

- 选择 Remote Mount 选项 M7, M8, M9 时, 电缆分布电容小于 24nF, 分布电感小于 60 $\mu$ H。
- 该产品必须与已通过防爆认证的关联设备配套共同组成本安防爆系统方可用于爆炸性气体环境。其系统接线必须同时遵守本产品 and 所配关联设备的使用说明书要求, 接线端子不得接错。
- 用户不得自行更换该产品的零部件, 应会同产品制造商共同解决运行中出现的故障, 以杜绝损坏现象的发生。
- 用于爆炸性粉尘环境中, 电缆引入口须选用国家指定的防爆检验机构按检验认可, 具有 Ex tD A20 IP66 防爆等级的电缆引入装置或堵封件, 冗余电缆引入口须用堵封件有效密封。
- 产品的安装, 使用和维护应同时遵守产品使用说明书, GB3836.13-2013 “爆炸性环境 第 13 部分: 设备的修理, 检修, 修复和改造”, GB3836.15-2000 “爆炸性气体环境用电气设备 第 15 部分: 危险场所电气安装 (煤矿除外)”, GB3836.16-2006 “爆炸性气体环境用电气设备 第 16 部分: 电气装置的检查和维护 (煤矿除外)”, GB3836.18-2010 “爆炸性环境 第 18 部分: 本质安全系统” 和 GB50257-2014 “电气装置安装工程爆炸和火灾危险环境电力装置施工及验收规范” 和 GB15577-2007 “粉尘防爆安全规程”, GB12476.2-2010 “可燃性粉尘环境用电气设备 第 2 部分”: 选型和安装的有关规定。

### N3 China Type n

**Certificate** 3051S, 3051SHP: GYJ17.1354X  
3051SFX: GYJ17.1355X

**Markings** Ex nA IIC T5 Gc

#### 产品安全使用特殊条件

- 产品防爆合格证号后缀“X”代表产品安全使用有特殊条件: 产品选用瞬态保护端子板 (c 中包含 T1 选项) 时, 设备不能承受 500V 对地电压试验 1 分钟, 安装时需考虑在内。
- 产品使用注意事项
  - 产品使用环境温度范围为:  $-40^{\circ}\text{C} \leq T_a \leq +85^{\circ}\text{C}$
  - 最高输入电压: 45V
  - 现场安装时, 电缆引入口须选用经国家指定的防爆检验机构检验认可的, 具有 Ex eIIC Gb 或 Ex nA IIC Gc 防爆等级的电缆引入装置或堵封件, 冗余电缆引入口须用堵封件有效密封。
  - 安装现场确认无可燃性气体存在时方可维修。

5. 用户不得自行更换该产品的零部件, 应会同产品制造商共同解决运行中出现的故障, 以杜绝损坏现象的发生.
6. 产品的安装, 使用和维护应同时遵守产品使用说明书, GB3836.13-2013 “爆炸性环境 第 13 部分: 设备的修理, 检修, 修复和改造”, GB3836.15-2000 “爆炸性气体环境用电气设备 第 15 部分: 危险场所电气安装 (煤矿除外)”, GB3836.16-2006 “爆炸性气体环境用电气设备 第 16 部分: 电气装置的检查和维护 (煤矿除外)”, GB50257-2014 “电气装置安装工程爆炸和火灾危险环境电力装置施工及验收规范” 的有关规定.

### EAC - Belarus, Kazakhstan, Russia

#### EM Technical Regulation Customs Union (EAC) Flameproof and Dust Ignition-proof

**Certificate** EAЭC RU C-US.AA87.B.00587/20  
**Markings** Ga/Gb Ex d IIC T6...T4 X  
 Ex tb IIIC T105 °C T<sub>500</sub> 95 °C Db X  
 Ex ta IIIC T105 °C T<sub>500</sub> 95 °C Da X

#### IM Technical Regulation Customs Union (EAC) Intrinsic Safety

**Certificate** EAЭC RU C-US.AA87.B.00587/20  
**Markings** 0Ex ia IIC T4 Ga X

#### IN Technical Regulation Customs Union (EAC) Intrinsic Safety

**Certificate:** EAЭC RU C-US.AA87.B.00587/20  
**Markings:** 0Ex ia IIC T4 Ga X

## Japan

### E4 Japan Flameproof

**Certificate** CML 17JPN1147X  
**Markings** Ex d IIC T6...T4 Ga/Gb

Temperature class	Ambient temperature	Process temperature
T6	-40 °C to +70 °C	-60 °C to +70 °C
T5	-40 °C to +75 °C	-60 °C to +80 °C
T4	-40 °C to +75 °C	-60 °C to +120 °C

### Special Conditions for Safe Use:

1. This device contains a thin wall diaphragm less than 1mm thickness that forms a boundary between EPL Ga (process connection) and EPL Gb (all other parts of the equipment). The model code and datasheet are to be consulted for details of the diaphragm material. Installation, maintenance, and use shall consider the environmental conditions to which the diaphragm will be subjected. The manufacturer’s instructions for installation and maintenance shall be followed in detail to assure safety during its expected lifetime.
2. Flameproof joints are not intended for repair.
3. Non-standard paint options may cause risk from electrostatic discharge. Avoid installations that could cause electrostatic build-up on painted surfaces, and only clean the painted surfaces with a damp cloth. If paint is ordered through a special option code, contact the manufacturer for more information.



## Republic of Korea

### EP Republic of Korea Flameproof

**Certificate** 19-KA4BO-0913X [Mfg USA], 12-KB4BO-0180X [Mfg USA], 11-KB4BO-0068X [Mfg Singapore]

**Markings** Ex d IIC T6...T4 Ga/Gb

### IP Republic of Korea Intrinsic Safety

**Certificate** 12-KB4BO-0202X [HART – Mfg USA], 12-KB4BO-0204X [Fieldbus – Mfg USA], 19-KA4BO-0844X [HART – Mfg USA], 19-KA4BO-0845X [Fieldbus – Mfg USA], 12-KB4BO-0203X [HART – Mfg Singapore], 13-KB4BO-0296X [Fieldbus – Mfg Singapore], 19-KA4BO-0845X [Fieldbus- Mfg USA], 19-KA4BO-0844X [HART- Mfg USA]

**Markings** Ex ia IIC T4

## Combinations

<b>K1</b>	Combination of E1, I1, N1, and ND
<b>K2</b>	Combination of E2 and I2
<b>K5</b>	Combination of E5 and I5
<b>K6</b>	Combination of E6 and I6
<b>K7</b>	Combination of E7, I7, and N7
<b>KA</b>	Combination of E1, I1, E6, and I6
<b>KB</b>	Combination of E5, I5, E6, and I6
<b>KC</b>	Combination of E1, I1, E5, and I5
<b>KD</b>	Combination of E1, I1, E5, I5, E6, and I6
<b>KG</b>	Combination of IA, IE, IF, and IG
<b>KM</b>	Combination of EM and IM
<b>KP</b>	Combination of EP and IP

## Additional Certifications

### SBS American Bureau of Shipping (ABS) Type Approval

**Certificate** 17-RJ1679518-PDA

**Intended Use** Measure gauge or absolute pressure of liquid, gas or vapor applications on ABS classed vessels, marine, and offshore installations.

### SBV Bureau Veritas (BV) Type Approval

**Certificate** 31910 BV

**Requirements** Bureau Veritas Rules for the Classification of Steel Ships

**Application** Class Notations: AUT-UMS, AUT-CCS, AUT-PORT and AUT-IMS.

### SDN Det Norske Veritas (DNV) Type Approval

**Certificate** TAA00000K9

**Intended Use** Det Norske Veritas' Rules for Classification of Ships, High Speed & Light Craft, and Det Norske Veritas' Offshore Standards

**Application**

Location classes	
Type	3051S
Temperature	D
Humidity	B
Vibration	A
EMC	A
Enclosure	D/IP66/IP68

**SLL Lloyds Register (LR) Type Approval**

**Certificate** 11/60002

**Application** Environmental categories ENV1, ENV2, ENV3, and ENV5

**D3 Custody Transfer - Measurement Canada Accuracy Approval [3051S Only]**

**Certificate** AG-0501, AV-2380C

## Rosemount 3051S and 3051SMV Wireless

Rev 2.5

### European directive information

A copy of the EC Declaration of Conformity can be found at the end of the Quick Start Guide. The most recent revision of the EC Declaration of Conformity can be found at [Emerson.com/Rosemount](https://www.emerson.com/Rosemount).

### Telecommunication Compliance

All wireless devices require certification to ensure that they adhere to regulations regarding the use of the RF spectrum. Nearly every country requires this type of product certification.

Emerson is working with governmental agencies around the world to supply fully compliant products and remove the risk of violating country directives or laws governing wireless device usage.

### FCC and IC

This device complies with Part 15 of the FCC Rules. Operation is subject to the following conditions: This device may not cause harmful interference. This device must accept any interference received, including interference that may cause undesired operation. This device must be installed to ensure a minimum antenna separation distance of 20 cm from all persons.

### Ordinary location certification

As standard, the transmitter has been examined and tested to determine that the design meets the basic electrical, mechanical, and fire protection requirements by a nationally recognized test laboratory (NRTL) as accredited by the Federal Occupational Safety and Health Administration (OSHA).

### Installing Equipment in North America

The US National Electrical Code (NEC) and the Canadian Electrical Code (CEC) permit the use of Division marked equipment in Zones and Zone marked equipment in Divisions. The markings must be suitable for the area classification, gas, and temperature class. This information is clearly defined in the respective codes.

## USA

### I5 USA Intrinsically Safe (IS), Nonincendive (NI), and Dust-Ignitionproof (DIP)

**Certificate** FM18US0009X

**Standards** FM Class 3600 – 2011, FM Class 3610 – 2010, FM Class 3611 – 2004, FM Class 3810 – 2005, NEMA 250 – 2003

**Markings** IS CL I, DIV 1, GP A, B, C, D; CL II, DIV 1, GP E, F, G; CL III T4; CL 1, Zone 0 AEx ia IIC T4; NI CL 1, DIV 2, GP A, B, C, D T4; DIP CL II, DIV 1, GP E, F, G; CL III, T5; T4(-50 °C ≤ T<sub>a</sub> ≤ +70 °C) / T5(-50 °C ≤ T<sub>a</sub> ≤ +85 °C); when connected per Rosemount drawing 03151-1000; Type 4X

### Special Conditions for Safe Use (X):

1. The Rosemount 3051S and SMV Wireless Transmitters shall only be used with the 701PBKKF Rosemount SmartPower Battery Pack (P/N 00753-9220-0001), Computational Systems Inc Battery Pack (P/N MHM-89004) or alternatively the Perpetuum Intelligent Power Module Vibration Harvester (P/N IPM71008).
2. The transmitter may contain more than 10% aluminum and is considered a potential risk of ignition by impact or friction. Care must be taken into account during installation and use to prevent impact and friction.
3. The surface resistivity of the antenna is greater than 1GΩ. To avoid electrostatic charge build-up, it must not be rubbed or cleaned with solvents or a dry cloth.

## Canada

### I6 Canada Intrinsically Safe

**Certificate** CSA 1143113

**Standards** CAN/CSA C22.2 No. 0-10, CSA Std C22.2 No. 30-M1986, CAN/CSA C22.2 No. 94-M91, CSA Std C22.2 No. 142-M1987, CSA Std C22.2 No. 157-92, ANSI/ISA 12.27.01-2003, CSA Std C22.2 No. 60529:05

**Markings** Intrinsically Safe Class I, Division 1; suitable for Class 1, Zone 0, IIC, T3C; when connected per Rosemount drawing 03151-1010; Type 4X

## Europe

### I1 ATEX Intrinsic Safety

**Certificate** Baseefa13ATEX0127X  
**Standards** EN 60079-0: 2012, EN 60079-11: 2012  
**Markings** Ⓜ II 1 G Ex ia IIC T4 Ga, T4(-60 °C ≤ T<sub>a</sub> ≤ +70 °C)

#### Special Conditions for Safe Use (X):

1. The Rosemount 3051S Wireless and Rosemount 3051SMV Wireless enclosure may be made of aluminum alloy and given a protective polyurethane paint finish; however, care should be taken to protect it from impact or abrasion if located in a zone 0 area.
2. The surface resistivity of the antenna is greater than 1 GΩ. To avoid electrostatic charge build-up, it must not be rubbed or cleaned with solvents or dry cloth.

## International

### I7 IECEx Intrinsic Safety

**Certificate** IECEx BAS 13.0068X  
**Standards** IEC 60079-0:2011, IEC 60079-11:2011  
**Markings** Ex ia IIC T4 Ga, T4(-60 °C ≤ T<sub>a</sub> ≤ +70 °C)

#### Special Conditions for Safe Use (X):

1. The Rosemount 3051S Wireless and Rosemount 3051SMV Wireless enclosure may be made of aluminum alloy and given a protective polyurethane paint finish; however, care should be taken to protect it from impact or abrasion if located in a zone 0 area.
2. The surface resistivity of the antenna is greater than 1GΩ . To avoid electrostatic charge build-up, it must not be rubbed or cleaned with solvents or dry cloth.

## Brazil

### I2 INMETRO Intrinsic Safety

**Certificate** UL-BR 14.0760X  
**Standards** ABNT NBR IEC60079-0:2008 + Errata 1:2011, ABNT NBR IEC60079-11: 2009  
**Markings** Ex ia IIC T4 Ga, T4(-60 °C ≤ T<sub>a</sub> ≤ +70 °C)

#### Special Condition for Safe Use (X):

1. See certificate.

## China

### I3 China Intrinsic Safety

<b>Certificate</b>	3051S Wireless: GYJ161250X 3051SFX: GYJ16.1465X [flow meters]
<b>Standards</b>	GB3836.1-2010, GB3836.4-2010, GB3836.20-2010
<b>Markings</b>	Ex ia IIC T4 Ga, T4(-60~70 °C)

#### Special Condition for Safe Use (X):

1. See appropriate certificate.

#### Note

Not currently available on the Rosemount 3051S MultiVariable Wireless Transmitter.

## Japan

### I4 CML Intrinsically Safe

<b>Certificate</b>	CML20JPN2011X
<b>Markings</b>	Ex ia IIC T4 Ga (-60 °C ≤ T <sub>a</sub> ≤ +70 °C), Ex ia IIC T5 Ga (-60 °C ≤ T <sub>a</sub> ≤ +40 °C)

## EAC - Belarus, Kazakhstan, Russia

### IM EAC Intrinsic Safety

<b>Certificate</b>	TC RU C-US.AA87.B.00378
<b>Markings</b>	0Ex ia IIC T4 Ga X (-60 °C ≤ T <sub>a</sub> ≤ +70 °C)

#### Special Condition for Safe Use (X):

1. See certificate for special conditions.

#### Note

Not currently available on the Rosemount 3051S MultiVariable Wireless Transmitter.

## Republic of Korea

### EP Republic of Korea Flameproof

<b>Certificate</b>	19-KA4BO-0913X [Mfg USA], 12-KB4BO-0180X [Mfg USA], 11-KB4BO-0068X [Mfg Singapore]
<b>Markings</b>	Ex d IIC T6...T4 Ga/Gb

### IP Republic of Korea Intrinsic Safety [HART Only]

<b>Certificate</b>	10-KB4BO-0021X [Mfg SMMC], 16-KB4BO-0440X [Mfg USA], 19-KA4BO-0911X [Mfg USA]
<b>Markings</b>	Ex ia IIC T4

## Combinations

<b>KQ</b>	Combination of I1, I5, and I6
-----------	-------------------------------

## Rosemount 3051SMV/3051SFx

Rev 2.7

### European directive information

A copy of the EC Declaration of Conformity can be found at the end of the Quick Start Guide. The most recent revision of the EC Declaration of Conformity can be found at [Emerson.com/Rosemount](http://Emerson.com/Rosemount).

### Ordinary location certification

As standard, the transmitter has been examined and tested to determine that the design meets the basic electrical, mechanical, and fire protection requirements by a nationally recognized test laboratory (NRTL) as accredited by the Federal Occupational Safety and Health Administration (OSHA).

### Installing Equipment in North America

The US National Electrical Code (NEC) and the Canadian Electrical Code (CEC) permit the use of Division marked equipment in Zones and Zone marked equipment in Divisions. The markings must be suitable for the area classification, gas, and temperature class. This information is clearly defined in the respective codes.

## USA

### E5 US Explosionproof (XP) and Dust-Ignitionproof (DIP)

**Certificate** FM16US0089X

**Standards** FM Class 3600 – 2011, FM Class 3615 – 2006, FM Class 3616 – 2011, 3810 – 2005, ANSI/NEMA 250 – 2003

**Markings** XP CL I, DIV 1, GP B, C, D; T5; DIP CL II, DIV 1, GP E, F, G; CL III; T5(-50 °C ≤ T<sub>a</sub> ≤ +85 °C); Factory Sealed; Type 4X

### I5 US Intrinsically Safe (IS) and Nonincendive (NI)

**Certificate** FM16US0233

**Standards** FM Class 3600 – 2011, FM Class 3610 – 2007, FM Class 3611 – 2004, FM Class 3616 – 2006, FM Class 3810 – 2005, NEMA 250 – 1991

**Markings** IS CL I, DIV 1, GP A, B, C, D; CL II, DIV 1, GP E, F, G; Class III; Class 1, Zone 0 AEx ia IIC T4; NI CL 1, DIV 2, GP A, B, C, D; T4(-50 °C ≤ T<sub>a</sub> ≤ +70 °C) when connected per Rosemount drawing 03151-1206; Type 4X

### Note

Transmitters marked with NI CL 1, DIV 2 can be installed in Division 2 locations using general Division 2 wiring methods or Nonincendive Field Wiring (NIFW). See Drawing 03151-1206.

### US Intrinsic Safety (IS) and Nonincendive (NI)

**Certificate:** 1143113

**Standards:** FM Class 3600:2011, FM Class 3610:2010, FM Class 3611:2004, FM Class 3810:2005, UL50E (1st Ed.)

**Markings:** IS Class I/II/III, Division 1, Groups A, B, C, D, T4/ E, F, and G T135 °C; Class I, Zone 0 AEx ia IIC T4 Ga; T4 (-50 °C ≤ T<sub>a</sub> ≤ +70 °C) [HART]; T4 (-50 °C ≤ T<sub>a</sub> ≤ +60 °C) [Fieldbus]; when connected per Rosemount drawing 03151-1207; Type 4X

### IE US FISCO Intrinsically Safe

**Certificate** FM16US0233

**Standards** FM Class 3600 – 2011, FM Class 3610 – 2010, FM Class 3611 – 2004, FM Class 3616 – 2006, FM Class 3810 – 2005, NEMA 250 – 1991

**Markings** IS CL I, DIV 1, GP A, B, C, D; T4(-50 °C ≤ T<sub>a</sub> ≤ +70 °C); when connected per Rosemount drawing 03151-1006; Type 4X

**US FISCO Intrinsically Safe**

**Certificate:** 1143113

**Standards:** FM Class 3600:2011, FM Class 3610:2010, FM Class 3611:2004, FM Class 3810:2005, UL50E (1st Ed.)

**Markings:** IS Class I/II/III, Division 1, Groups A, B, C, D, T4/ E, F, and G T135 °C; Class I, Zone 0 AEx ia IIC T4 Ga; T4 (-50 °C ≤ T<sub>a</sub> ≤ +70 °C) [HART]; T4 (-50 °C ≤ T<sub>a</sub> ≤ +60 °C) [Fieldbus]; when connected per Rosemount drawing 03151-1207; Type 4X

**Canada**

**E6 Canada Explosionproof, Dust Ignition-proof, Division 2**

**Certificate** 1143113

**Standards** CAN/CSA C22.2 No. 0-10, CSA Std C22.2 No. 25-1966, CSA Std C22.2 No. 30-M1986, CSA C22.2 No. 94.2-07 , CSA Std C22.2 No. 213-M1987, CAN/CSA C22.2 60079-11:14, CAN/CSA-C22.2 No. 61010-1-12, ANSI/ISA 12.27.01-2003, CSA Std C22.2 No. 60529:05 (R2010)

**Markings** Explosionproof Class I, Division 1, Groups B, C, D; Dust-Ignitionproof Class II, Division 1, Groups E, F, G; Class III; suitable for Class I, Division 2, Groups A, B, C, D; Type 4X

**I6 Canada Intrinsically Safe**

**Certificate** 1143113

**Standards** CAN/CSA C22.2 No. 0-10, CSA Std C22.2 No. 25-1966, CSA Std C22.2 No. 30-M1986, CSA C22.2 No. 94.2-07 , CSA Std C22.2 No. 213-M1987, CAN/CSA C22.2 60079-11:14, CAN/CSA-C22.2 No. 61010-1-12, ANSI/ISA 12.27.01-2003, CSA Std C22.2 No. 60529:05 (R2010)

**Markings** Intrinsically Safe Class I, Division 1; Groups A, B, C, D; suitable for Class 1, Zone 0, IIC, T3C, T<sub>a</sub> = 70 °C; when connected per Rosemount drawing 03151-1207; Type 4X

**IF Canada FISCO Intrinsically Safe**

**Certificate** 1143113

**Standards** CAN/CSA C22.2 No. 0-10, CSA Std C22.2 No. 25-1966, CSA Std C22.2 No. 30-M1986, CSA C22.2 No. 94.2-07 , CSA Std C22.2 No. 213-M1987, CAN/CSA C22.2 60079-11:14, CAN/CSA-C22.2 No. 61010-1-12, ANSI/ISA 12.27.01-2003, CSA Std C22.2 No. 60529:05 (R2010)

**Markings** FISCO Intrinsically Safe Class I, Division 1; Groups A, B, C, D; suitable for Class I, Zone 0; T3C, T<sub>a</sub> = 70 °C; when installed per Rosemount drawing 03151-1207; Type 4X

**Europe**

**E1 ATEX Flameproof**

**Certificate** KEMA 00ATEX2143X

**Standards** EN 60079-0:2012+A11:2013, EN 60079-1: 2014, EN 60079-26:2015

**Markings** Ex II 1/2 G Ex db IIC T6...T4 Ga/Gb, T6(-60 °C ≤ T<sub>a</sub> ≤ +70 °C), T5/T4(-60 °C ≤ T<sub>a</sub> ≤ +80 °C)

Temperature class	Process temperature
T6	-60 °C to +70 °C
T5	-60 °C to +80 °C
T4	-60 °C to +120 °C

**Special Conditions for Safe Use (X):**

1. This device contains a thin wall diaphragm less than 1 mm thickness that forms a boundary between Category 1 (process connection) and Category 2 (all other parts of the equipment). The model code and datasheet are to be consulted for details of the diaphragm material. Installation, maintenance, and use shall take into account the environmental conditions to which the diaphragm will be subjected. The manufacturer's instructions for installation and maintenance shall be followed in detail to assure safety during its expected lifetime.
2. Flameproof joints are not intended for repair.
3. Non-standard paint options may cause risk from electrostatic discharge. Avoid installations that could cause electrostatic build-up on painted surfaces, and only clean the painted surfaces with a damp cloth. If paint is ordered through a special option code, contact the manufacturer for more information.
4. Appropriate cable, glands, and plugs need to be suitable for a temperature of 5 °C greater than maximum specified temperature for location where installed.

**I1 ATEX Intrinsic Safety**

**Certificate** Baseefa08ATEX0064X  
**Standards** EN 60079-0:2012, EN 60079-11:2012  
**Markings** Ex II 1 G Ex ia IIC T4 Ga, T4(-60 °C ≤ T<sub>a</sub> ≤ +70 °C)

Parameter	HART®	FOUNDATION™ Fieldbus	SuperModule™ only	RTD (for 3051SFx)	
				HART	Fieldbus
Voltage U <sub>i</sub>	30 V	30 V	7.14 V	30 V	30 V
Current I <sub>i</sub>	300 mA	300 mA	300 mA	2.31 mA	18.24 mA
Power P <sub>i</sub>	1 W	1.3 W	887 mW	17.32 mW	137 mW
Capacitance C <sub>i</sub>	14.8 nF	0	0.11 μF	0	0.8 nF
Inductance L <sub>i</sub>	0	0	0	0	1.33 mH

**Special Conditions for Safe Use (X):**

1. If the equipment is fitted with the optional 90 V transient suppressor, it is incapable of withstanding the 500 V isolation from earth test and this must be taken into account during installation.
2. The enclosure may be made of aluminum alloy and given a protective polyurethane paint finish; however, care should be taken to protect it from impact or abrasion if located in a Zone 0 environment.

**IA ATEX FISCO**

**Certificate** Baseefa08ATEX0064X  
**Standards** EN 60079-0:2012, EN 60079-11:2012  
**Markings** Ex II 1 G Ex ia IIC T4 Ga, T4(-60 °C ≤ T<sub>a</sub> ≤ +70 °C)

Parameter	FISCO
Voltage U <sub>i</sub>	17.5 V
Current I <sub>i</sub>	380 mA
Power P <sub>i</sub>	5.32 W
Capacitance C <sub>i</sub>	0
Inductance L <sub>i</sub>	0



**ND ATEX Dust**

**Certificate** BAS01ATEX1374X  
**Standards** EN 60079-0:2012+A11:2013, EN 60079-31:2009  
**Markings** Ex II 1 D Ex ta IIIC T105 °C T<sub>500</sub> 95 °C Da, (-20 °C ≤ T<sub>a</sub> ≤ +85 °C), V<sub>max</sub> = 42.4 V

**Special Conditions for Safe Use (X):**

1. Cable entries must be used which maintain the ingress protection of the enclosure to at least IP66.
2. Unused cable entries must be filled with suitable blanking plugs which maintain the ingress protection of the enclosure to at least IP66.
3. Cable entries and blanking plugs must be suitable for the ambient temperature range of the apparatus and capable of withstanding a 7J impact test.
4. The SuperModule(s) must be securely screwed in place to maintain the ingress protection of the enclosure(s).

**N1 ATEX Type n**

**Certificate** Baseefa08ATEX0065X  
**Standards** EN 60079-0:2012, EN 60079-15:2010  
**Markings** Ex II 3 G Ex nA IIC T4 Gc, (-40 °C ≤ T<sub>a</sub> ≤ 70 °C), V<sub>max</sub> = 45 V

**Special Condition for Safe Use (X):**

1. If fitted with a 90 V transient suppressor, the equipment is not capable of withstanding the 500 V electrical strength test as defined in Clause 6.5.1 of EN 60079-15:2010. This must be taken into account during installation.

**International**

**E7 IECEx Flameproof and Dust**

**Certificate** IECEx KEM 08.0010X (Flameproof)  
**Standards** IEC 60079-0:2011, IEC 60079-1:2014, IEC 60079-26:2014  
**Markings** Ex db IIC T6...T4 Ga/Gb, T6(-60 °C ≤ T<sub>a</sub> ≤ +70 °C), T5/T4(-60 °C ≤ T<sub>a</sub> ≤ +80 °C)

Temperature class	Process temperature
T6	-60 °C to +70 °C
T5	-60 °C to +80 °C
T4	-60 °C to +120 °C

**Special Conditions for Safe Use (X):**

1. This device contains a thin wall diaphragm less than 1 mm thickness that forms a boundary between EPL Ga (process connection) and EPL Gb (all other parts of the equipment). The model code and datasheet are to be consulted for details of the diaphragm material. Installation, maintenance and use shall take into account the environmental conditions to which the diaphragm will be subjected. The manufacturer's instructions for installation and maintenance shall be followed in detail to assure safety during its expected lifetime.
2. Flameproof joints are not intended for repair.
3. Non-standard paint options may cause risk from electrostatic discharge. Avoid installations that could cause electrostatic build-up on painted surfaces, and only clean the painted surfaces with a damp cloth. If paint is ordered through a special option code, contact the manufacturer for more information.

- Appropriate cable, glands and plugs need to be suitable for a temperature of 5 °C greater than maximum specified temperature for location where installed.

**Certificate** IECEx BAS 09.0014X (Dust)  
**Standards** IEC 60079-0:2011, IEC 60079-31:2008  
**Markings** Ex ta IIIC T105 °C T<sub>500</sub> 95 °C Da, (-20 °C ≤ T<sub>a</sub> ≤ +85 °C), V<sub>max</sub> = 42.4 V

**Special Conditions for Safe Use (X):**

- Cable entries must be used which maintain the ingress protection of the enclosure to at least IP66.
- Unused cable entries must be filled with suitable blanking plugs which maintain the ingress protection of the enclosure to at least IP66.
- Cable entries and blanking plugs must be suitable for the ambient temperature range of the apparatus and capable of withstanding a 7J impact test.
- The Rosemount 3051S SuperModule™ must be securely screwed in place to maintain the ingress protection of the enclosure.

**I7 IECEx Intrinsic Safety**

**Certificate** IECEx BAS 08.0025X  
**Standards** IEC 60079-0:2011, IEC 60079-11:2011  
**Markings** Ex ia IIC T4 Ga, T4(-60 °C ≤ T<sub>a</sub> ≤ +70 °C)

Parameter	HART®	FOUNDATION™ Fieldbus	SuperModule™ only	RTD (for 3051SFx)	
				HART	Fieldbus
Voltage U <sub>i</sub>	30 V	30 V	7.14 V	30 V	30 V
Current I <sub>i</sub>	300 mA	300 mA	300 mA	2.31 mA	18.24 mA
Power P <sub>i</sub>	1 W	1.3 W	887 mW	17.32 mW	137 mW
Capacitance C <sub>i</sub>	14.8 nF	0	0.11 μF	0	0.8 nF
Inductance L <sub>i</sub>	0	0	0	0	1.33 mH

**Special Conditions for Safe Use (X):**

- If the equipment is fitted with the optional 90 V transient suppressor, it is incapable of withstanding the 500 V isolation from earth test and this must be taken into account during installation.
- The enclosure may be made of aluminum alloy and given a protective polyurethane paint finish; however, care should be taken to protect it from impact or abrasion if located in a Zone 0 environment.

**I7 IECEx Intrinsic Safety - Group 1 - Mining (I7 with Special A0259)**

**Certificate** IECEx TSA 20.0015X  
**Standards** IEC 60079-0: 2017, IEC 60079-11: 2011  
**Markings** Ex ia I Ma (-60 °C ≤ T<sub>a</sub> ≤ +70 °C)

Safety parameter	HART®	Safety parameter	RTD (HART)
Voltage $U_i$	30 V	Voltage $U_o$	30 V
Current $I_i$	300 mA	Current $I_o$	2.31 mA
Power $P_i$	1 W	Power $P_o$	17.32 mW
Capacitance $C_i$	14.8 nF	Capacitance $C_o$	33 nF
Inductance $L_i$	0	Inductance $L_o$	3.33 H

**Note**

This must be sourced from a resistively limited power supply.

**Specific Condition of Use (X):**

1. If the apparatus is fitted with optional 90 V transient suppressor, it is not capable of withstanding the 500 Vac insulation test required by Clause 6.3.13 of IEC60079-11. This must be taken into account when installing the apparatus.

**IG IECEx FISCO**

**Certificate** IECEx BAS 08.0025X  
**Standards** IEC 60079-0:2011, IEC 60079-11:2011  
**Markings** Ex ia IIC T4 Ga, T4(-60 °C ≤ T<sub>a</sub> ≤ +70 °C)

Parameter	FISCO
Voltage $U_i$	17.5 V
Current $I_i$	380 mA
Power $P_i$	5.32 W
Capacitance $C_i$	0
Inductance $L_i$	0

**N7 IECEx Type n**

**Certificate** IECEx BAS 08.0026X  
**Standards** IEC 60079-0:2011, IEC 60079-15:2010  
**Markings** Ex nA IIC T5 Gc, (-40 °C ≤ T<sub>a</sub> ≤ 70 °C)

**Special Condition for Safe Use (X):**

1. If fitted with a 90 V transient suppressor, the equipment is not capable of withstanding the 500 V electrical strength test as defined in Clause 6.5.1 of IEC 60079-15:2010. This must be taken into account during installation.

**Brazil**

**E2 INMETRO Flameproof**

**Certificate** UL-BR 15.0393X  
**Standards** ABNT NBR IEC 60079-0:2013, ABNT NBR IEC 60079-1:2016, ABNT NBR IEC 60079-26:2016  
**Markings** Ex db IIC T\* Ga/Gb, T6(-60 °C ≤ T<sub>a</sub> ≤ +70 °C), T5/T4 (-60 °C ≤ T<sub>a</sub> ≤ +80 °C), IP66

Temperature class	Ambient temperature	Process connection temperature
T6	-60 °C to +70 °C	-60 °C to +70 °C
T5	-60 °C to +80 °C	-60 °C to +80 °C
T4	-60 °C to +80 °C	-60 °C to +120 °C

### Special Conditions for Safe Use (X):

1. The device contains a thin wall diaphragm less than 1 mm thick that forms a boundary between zone 0 (process connection) and zone 1 (all other parts of the equipment). The model code and datasheet are to be consulted for details of the diaphragm material. Installation, maintenance, and use shall take into account the environmental conditions to which the diaphragm will be subjected. The manufacturer's instructions for maintenance shall be followed in detail to assure safety during its expected lifetime.
2. Flameproof joints are not intended for repair.
3. Non-standard paint options may cause risk from electrostatic discharge. Avoid installations that could cause electrostatic build-up on painted surfaces, and only clean the painted surfaces with a damp cloth. If paint is ordered through a special option code, contact the manufacturer for more information.

### I2 INMETRO Intrinsic Safety

**Certificate** UL-BR 15.0357X

**Standards** ABNT NBR IEC 60079-0:2008 + Addendum 1:2011, ABNT NBR IEC 60079-11:2009

**Markings** Ex ia IIC T4 Ga (-60 °C ≤ T<sub>a</sub> ≤ +70 °C)

### Special Conditions for Safe Use (X):

1. If the equipment is fitted with the optional 90 V transient suppressor, it is incapable of withstanding the 500 V isolation from earth test and this must be taken into account during installation.
2. The enclosure may be made of aluminium alloy and given a protective polyurethane paint finish; however, care should be taken to protect it from impact or abrasion if located in a Zone 0 environment, areas requiring EPL Ga.

Parameter	HART®		Fieldbus	
	Input	RTD	Input	RTD
Voltage U <sub>i</sub>	30 V	30 V	30 V	30 V
Current I <sub>i</sub>	300 mA	2.31 mA	300 mA	18.24 mA
Power P <sub>i</sub>	1 W	17.32 mW	1.3 W	137 mW
Capacitance C <sub>i</sub>	14.8 nF	0	0	0.8 nF
Inductance L <sub>i</sub>	0	0	0	1.33 mH

## China

### E3 China Flameproof and Dust Ignition-proof

**Certificate** 3051SMV: GYJ18.1550X [Mfg USA, China, Singapore]

3051SFx: GYJ11.1466X [Mfg USA, China, Singapore]

**Standards** 3051SMV: GB3836.1-2010, GB3836.2-2010, GB3836.20-2010

3051SFx: GB3836.1-2010, GB3836.2-2010, GB3836.20-2010, GB12476.1-2013, GB12476.5-2013

**Markings** 3051SMV: Ex d IIC T6-T4 Ga/Gb

3051SFx: Ex d IIC T4-T6 Ga/Gb; Ex tD T 105 °C T<sub>500</sub> 95 °C; IP66

**Special Conditions for Safe Use (X):**

一、产品安全使用特殊条件

证书编号后缀“X”表明产品具有安全使用特殊条件：

1. 涉及隔爆接合面的维修须联系产品制造商。
2. 产品使用厚度小于 1 mm 的隔膜作为 0 区（过程连接）和 1 区（产品其他部分）的隔离，安装和维护时需严格遵守制造商提供的说明书，以确保安全性。
3. 产品外部涂层可能产生静电危险，使用时须防止产生静电火花，只能用湿布清理。

二、产品使用注意事项

1. 产品温度组别和使用环境温度之间的关系为：

温度组别	使用环境温度	过程温度
T6	-60 °C to +70 °C	-60 °C to +70 °C
T5	-60 °C to +80 °C	-60 °C to +80 °C
T4	-60 °C to +80 °C	-60 °C to +120 °C

2. 用于爆炸性粉尘环境中，产品使用环境温度为： $-20\text{ °C} \leq T_a \leq +85\text{ °C}$ 。
3. 产品外壳设有接地端子，用户在使用时应可靠接地。
4. 安装现场应不存在对产品外壳有腐蚀作用的有害气体。
5. 现场安装时，电缆引入口须选用经国家指定的防爆检验机构检验认可、具有 Ex dIIC Gb, Ex tD A20 IP66 防爆等级的电缆引入装置或堵封件，冗余电缆引入口须用堵封件有效密封。
6. 用于爆炸性气体环境中，现场安装、使用和维护必须严格遵守“严禁带电开盖！”的警告语。
7. 用于爆炸性粉尘环境中，产品外壳表面需保持清洁，以防粉尘堆积，但严禁用压缩空气吹扫。
8. 用户不得自行更换该产品的零部件，应会同产品制造商共同解决运行中出现的故障，以杜绝损坏现象的发生。
9. 产品的安装、使用和维护应同时遵守产品使用说明书、GB3836.13-2013“爆炸性环境 第 13 部分：设备的修理、检修、修复和改造”、GB/T3836.15-2017“爆炸性环境 第 15 部分：电气装置的设计、选型和安装”、GB/T3836.16-2017“爆炸性环境 第 16 部分：电气装置的检查与维护”和 GB50257-2014“电气装置安装工程爆炸和火灾危险环境电力装置施工及验收规范”和 GB15577-2007“粉尘防爆安全规程”、GB12476.2-2010“可燃性粉尘环境用电气设备 第 2 部分：选型和安装”的有关规定。

**I3 China Intrinsic Safety**

**Certificate** 3051SMV: GYJ18.1551X [Mfg USA, China, Singapore]  
3051SFx: GYJ16.1465X [Mfg USA, China, Singapore]

**Standards** 3051SMV: GB3836.1-2010, GB3836.4-2010, GB3836.20-2010  
3051SFx: GB3836.1/4-2010, GB3836.20-2010, GB12476.1-2000

**Markings** 3051SMV: Ex ia IIC T4 Ga  
3051SFx: Ex ia IIC T4 Ga,

c 输出代码	防爆标志
A, F	Ex iaIIC T4 Ga , Ex tD A20 IP66 T105 °C T500 95 °C
X	Ex iaIIC T4 Ga

一、产品安全使用特殊条件

产品防爆合格证号后缀“X”代表产品安全使用有特殊条件:

1. 产品外壳含有轻金属，用于 0 区时需注意防止由于冲击或摩擦产生的点燃危险。
2. 此设备不能承受 GB3836.4-2010 标准中第 6.3.12 条规定的 500V 交流有效值试验电压的介电强度试验。
3. c 为 X 时，天线表面电阻大于 1 GΩ，为了避免静电积聚，不允许用溶剂或者干布擦拭；电源模块表面电阻大于 1 GΩ，如果在危险区域更换，则需要避免静电积聚；只能使用由原制造厂提供的 P/N 753-9220-XXXX 电池。

## 二、产品使用注意事项

1. 用于爆炸性气体环境中，产品使用环境温度为： $-60^{\circ}\text{C} \leq T_a \leq +70^{\circ}\text{C}$  用于爆炸性粉尘环境中，产品使用环境温度为： $-20^{\circ}\text{C} \leq T_a \leq +85^{\circ}\text{C}$
2. 本安电气参数：

c 输出代码	端子	最高输入电压 $U_i$ (V)	最大输入电流 $I_i$ (mA)	最大输入功率 $P_i$ (W)	最大内部等效参数	
					$C_i$ (nF)	$L_i$ (μH)
SuperModule	+, -, CAN	30	300	1	30	0
A	+, -, CAN	30	300	1	12	0
A 配 M7、M8 或 M9 显示	+, -	30	300	1	12	60
F	+, -	30	300	1.3	0	0
FISCO	+, -	17.5	300	5.32	0	0

d 代码为 A 时

	最高输出电压 $U_o$ (V)	最大输出电流 $I_o$ (mA)	最大输出功率 $P_o$ (mW)	最大内部等效参数	
				$C_i$ (nF)	$L_i$ (μH)
RTD	30	2.31	17.32	0	0
SuperModule	7.14	300	887	110	0

注：本安电气参数符合 GB3836.19-2010 对 FISCO 现场仪表的参数要求。

3. 选择 Remote Mount 选项 M7、M8、M9 时，电缆分布电容小于 24 nF，分布电感小于 60 μH。
4. 该产品必须与已通过防爆认证的关联设备配套共同组成本安防爆系统方可使用于爆炸性气体环境。其系统接线必须同时遵守本产品和所配关联设备的使用说明书要求，接线端子不得接错。
5. 用于爆炸性粉尘环境中，电缆引入口须选用国家指定的防爆检验机构按检验认可、具有 Ex tD A20 IP66 防爆等级的电缆引入装置或堵封件，冗余电缆引入口须用堵封件有效密封。
6. 用户不得自行更换该产品的零部件，应会同产品制造商共同解决运行中出现的故障，以杜绝损坏现象的发生。
7. 产品的安装、使用和维护应同时遵守产品使用说明书、GB3836.13-2013“爆炸性环境 第 13 部分：设备的修理、检修、修复和改造”、GB/T3836.15-2017“爆炸性环境 第 15 部分：电气装置的设计、选型和安装”、GB/T3836.16-2017“爆炸性环境 第 16 部分：电气装置的检查与维护”、GB/T 3836.18-2017“爆炸性环境 第 18 部分：本质安全电气系统”、GB50257-2014“电气装置安装工程爆炸和火灾危险环境电力装置施工及验收规范”GB12476.2-2010“可燃性粉尘环境用电气设备 第 2 部分：选型和安装”的有关规定。

## EAC - Belarus, Kazakhstan, Russia

### EM Technical Regulation Customs Union (EAC) Flameproof and Dust Ignition-proof

**Certificate** EAЭC RU C-US.AA87.B.00587/20

**Markings** Ga/Gb Ex d IIC T6...T4 X

Ex tb IIIC T105 °C T<sub>500</sub> 95 °C Db X

Ex ta IIIC T105 °C T<sub>500</sub> 95 °C Da X

**IM Technical Regulation Customs Union (EAC) Intrinsic Safety**

**Certificate** RU C-US.AA87.B.00378  
**Markings** 0Ex ia IIC T4 Ga X

**Japan**

**E4 Japan Flameproof**

**Certificate** CML 17JPN1147X  
**Markings** Ex d IIC T6...T4 Ga/Gb

**Table 43:**

Temperature class	Ambient temperature	Process temperature
T6	-40 to +70 °C (-40 to +158 °F)	-60 to +70 °C (-76 to +158 °F)
T5	-40 to +75 °C (-40 to +167 °F)	-60 to +80 °C (-76 to +176 °F)
T4	-40 to +75 °C (-40 to +167 °F)	-60 to +120 °C (-76 to +248 °F)

**Special Conditions for Safe Use (X):**

1. This device contains a thin wall diaphragm less than 1 mm thickness that forms a boundary between EPL Ga (process connection) and EPL Gb (all other parts of the equipment). The model code and datasheet are to be consulted for details of the diaphragm material. Installation, maintenance, and use shall consider the environmental conditions to which the diaphragm will be subjected. The manufacturer’s instructions for installation and maintenance shall be followed in detail to assure safety during its expected lifetime.
2. Flameproof joints are not intended for repair.
3. Non-standard paint options may cause risk from electrostatic discharge. Avoid installations that could cause electrostatic build-up on painted surfaces, and only clean the painted surfaces with a damp cloth. If paint is ordered through a special option code, contact the manufacturer for more information.

**Republic of Korea**

**EP Republic of Korea Flameproof**

**Certificate** 19-KA4BO-0913X [Mfg USA], 12-KB4BO-0180X [Mfg USA], 11-KB4BO-0068X [Mfg Singapore]  
**Markings** Ex d IIC T6...T4 Ga/Gb

**IP Republic of Korea Intrinsic Safety [HART Only]**

**Certificate** 10-KB4BO-0021X [Mfg SMMC], 16-KB4BO-0440X [Mfg USA], 19-KA4BO-0911X [Mfg USA]  
**Markings** Ex ia IIC T4

**Combinations**

- K1** Combination of E1, I1, N1, and ND
- K2** Combination of E2 and I2
- K5** Combination of E5 and I5
- K6** Combination of E6 and I6

- K7**           Combination of E7, I7, and N7
- KA**           Combination of E1, I1, E6, and I6
- KB**           Combination of E5, I5, E6, and I6
- KC**           Combination of E1, I1, E5, and I5
- KD**           Combination of E1, I1, E5, I5, E6, and I6
- KM**           Combination of EM and IM
- KP**           Combination of EP and IP

### Additional Certifications

#### SBS American Bureau of Shipping (ABS) Type Approval

- Certificate**   17-RJ1679518-PDA
- Intended Use** Measure gauge or absolute pressure of liquid, gas or vapor applications on ABS classed vessels, marine, and offshore installations. [HART only]

#### SBV Bureau Veritas (BV) Type Approval

- Certificate**         31910 BV
- Requirements**     Bureau Veritas Rules for the Classification of Steel Ships
- Application**        Class Notations: AUT-UMS, AUT-CCS, AUT-PORT and AUT-IMS. [HART only]

#### SDN Det Norske Veritas (DNV) Type Approval

- Certificate**   TAA00000K9
- Intended Use** Det Norske Veritas’ Rules for Classification of Ships, High Speed and Light Craft, and Det Norske Veritas’ Offshore Standards.[HART only]

**Application**

Location classes	
Type	3051S
Temperature	D
Humidity	B
Vibration	A
EMC	A
Enclosure	D/IP66/IP68

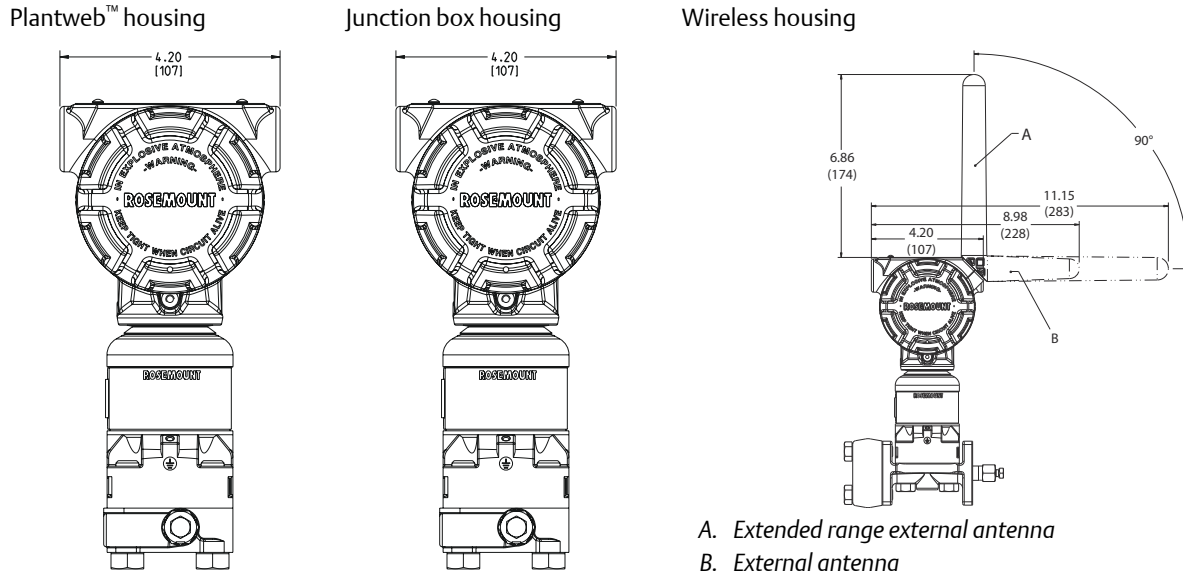
#### SLL Lloyds Register (LR) Type Approval

- Certificate**         11/60002
- Application**        Environmental categories ENV1, ENV2, ENV3, and ENV5. [HART only]



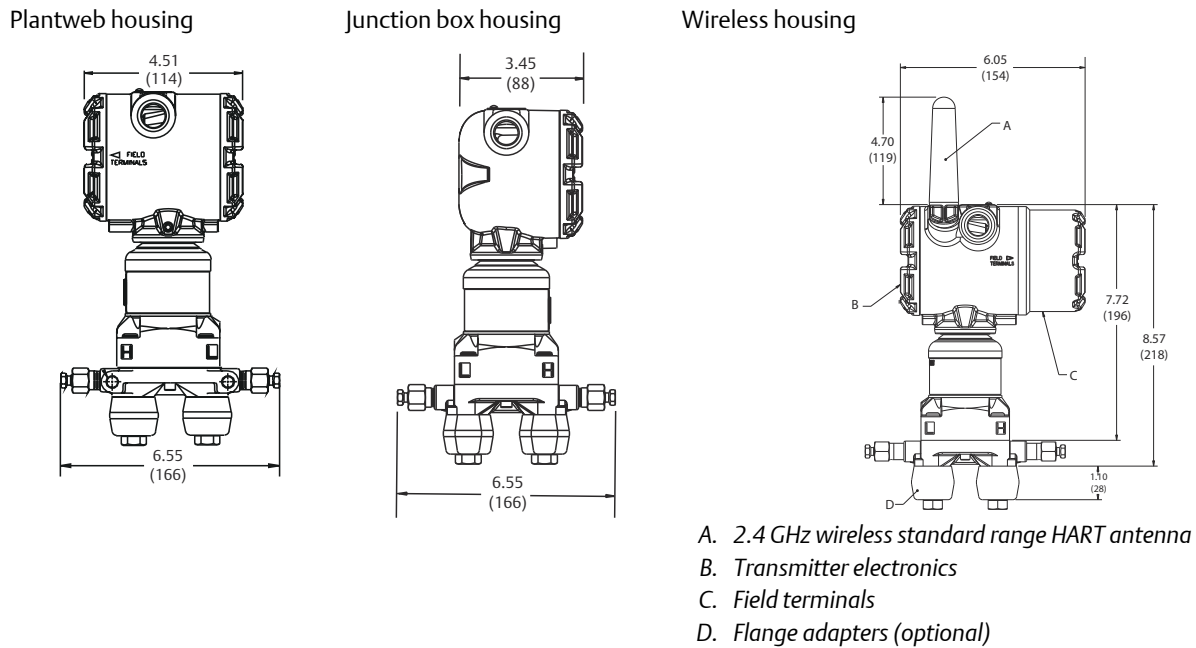
# Dimensional drawings

**Figure 10: Transmitter with Coplanar Sensor Module and Flange (Front View)**



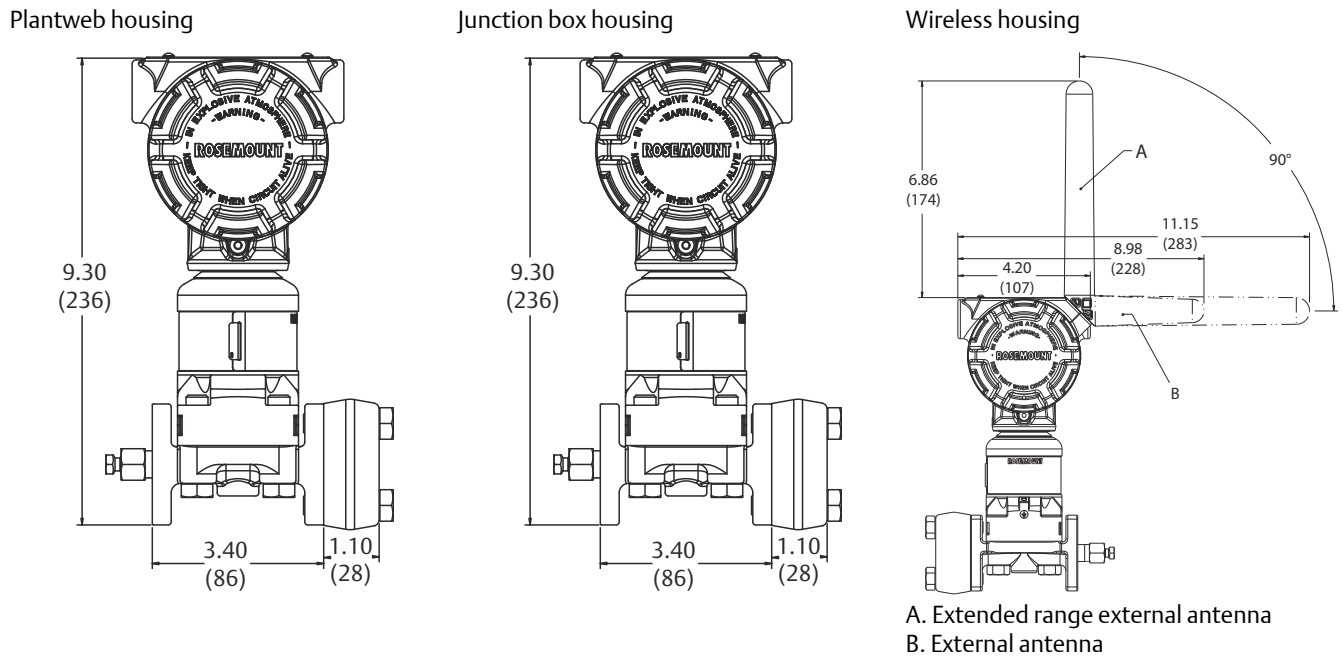
Dimensions are in inches (millimeters).

**Figure 11: Transmitter with Coplanar Sensor Module and Flange (Side View)**



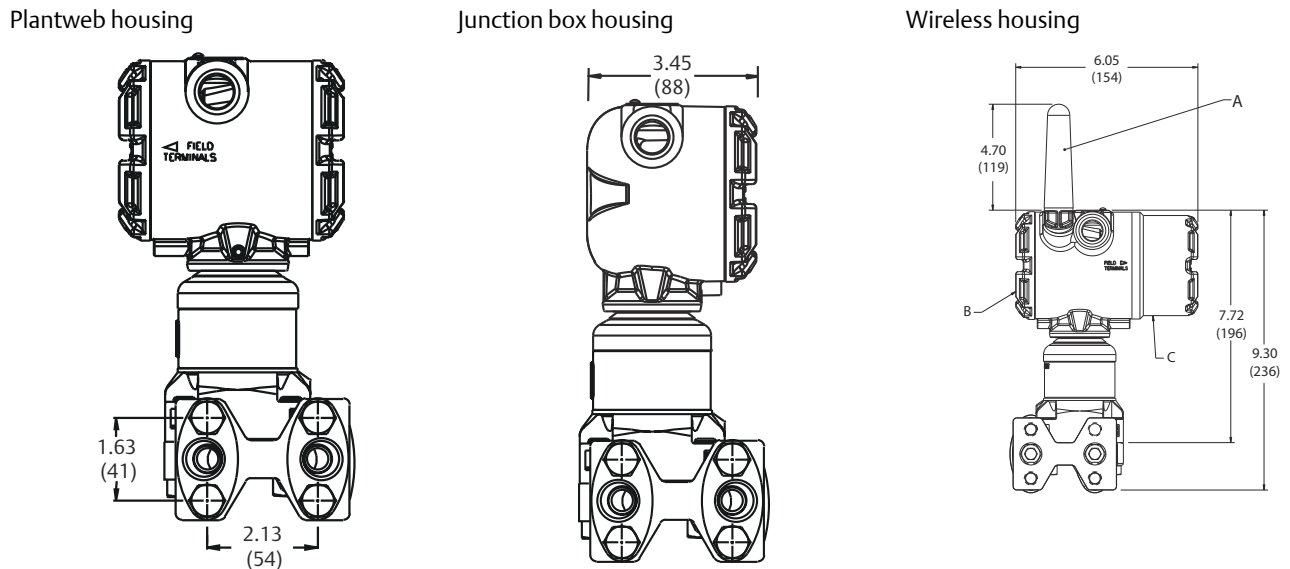
Dimensions are in inches (millimeters).

**Figure 12: Transmitter with Coplanar Sensor Module and Traditional Flange (Front View)**



Dimensions are in inches (millimeters).

**Figure 13: Transmitter with Coplanar Sensor Module and Traditional Flange (Side View)**



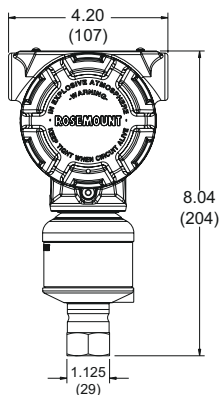
Dimensions are in inches (millimeters).

**Figure 14: Transmitter with In-line Sensor Module (Front View)**

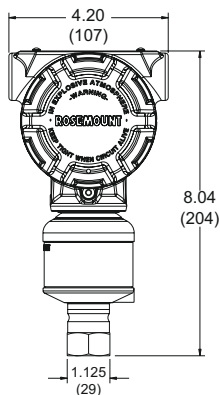
**Note**

For ranges 1A-4A, ½-in. NPT 316L SST process wetted connection. For detailed dimensions on other configurations, see Type I drawings at [Emerson.com/Rosemount](http://Emerson.com/Rosemount).

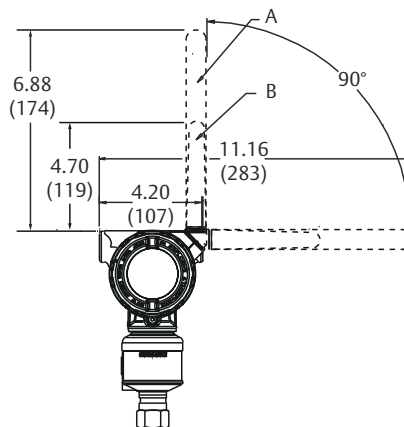
Plantweb housing



Junction box housing



Wireless housing



- A. Extended range external antenna
- B. External antenna

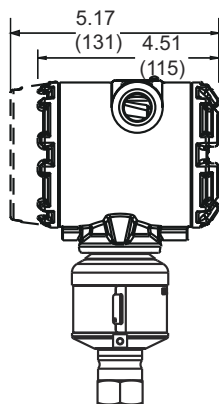
Dimensions are in inches (millimeters).

**Figure 15: Transmitter with In-line Sensor Module (Side View)**

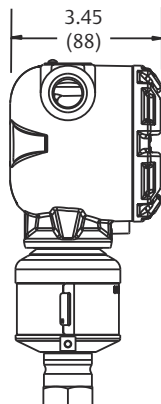
**Note**

For ranges 1A-4A, ½-in. NPT 316L SST process wetted connection. For detailed dimensions on other configurations, see Type I drawings at [Emerson.com/Rosemount](http://Emerson.com/Rosemount).

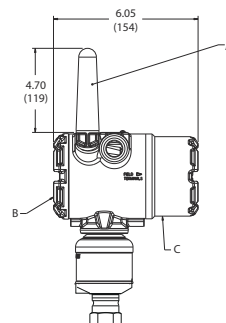
Plantweb housing



Junction box housing



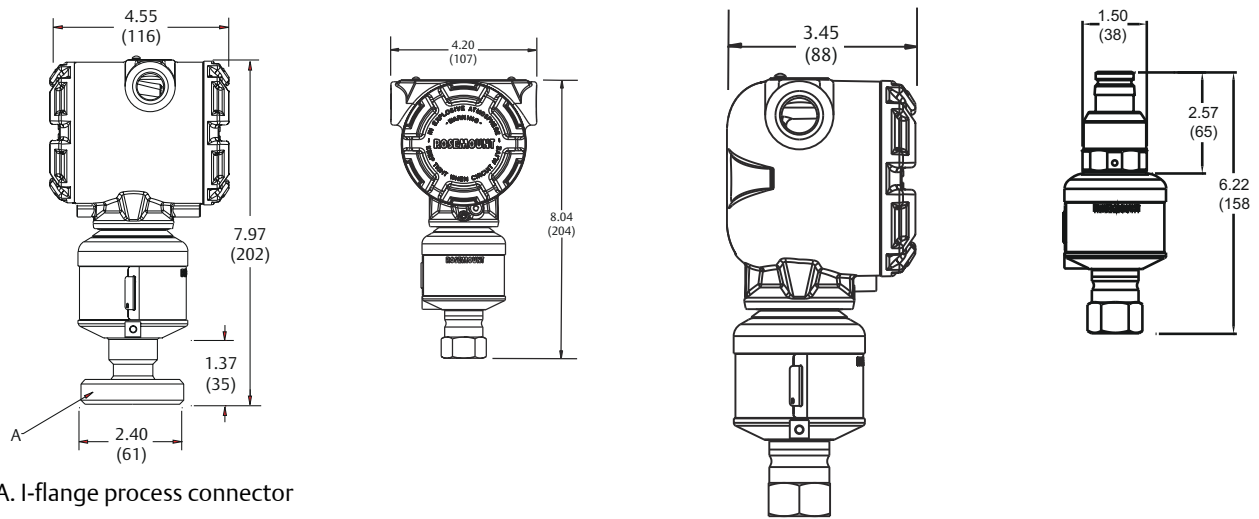
Wireless housing



- A. 2.4 GHz wireless standard range HART antenna
- B. Transmitter electronics
- C. Field terminals

Dimensions are in inches (millimeters).

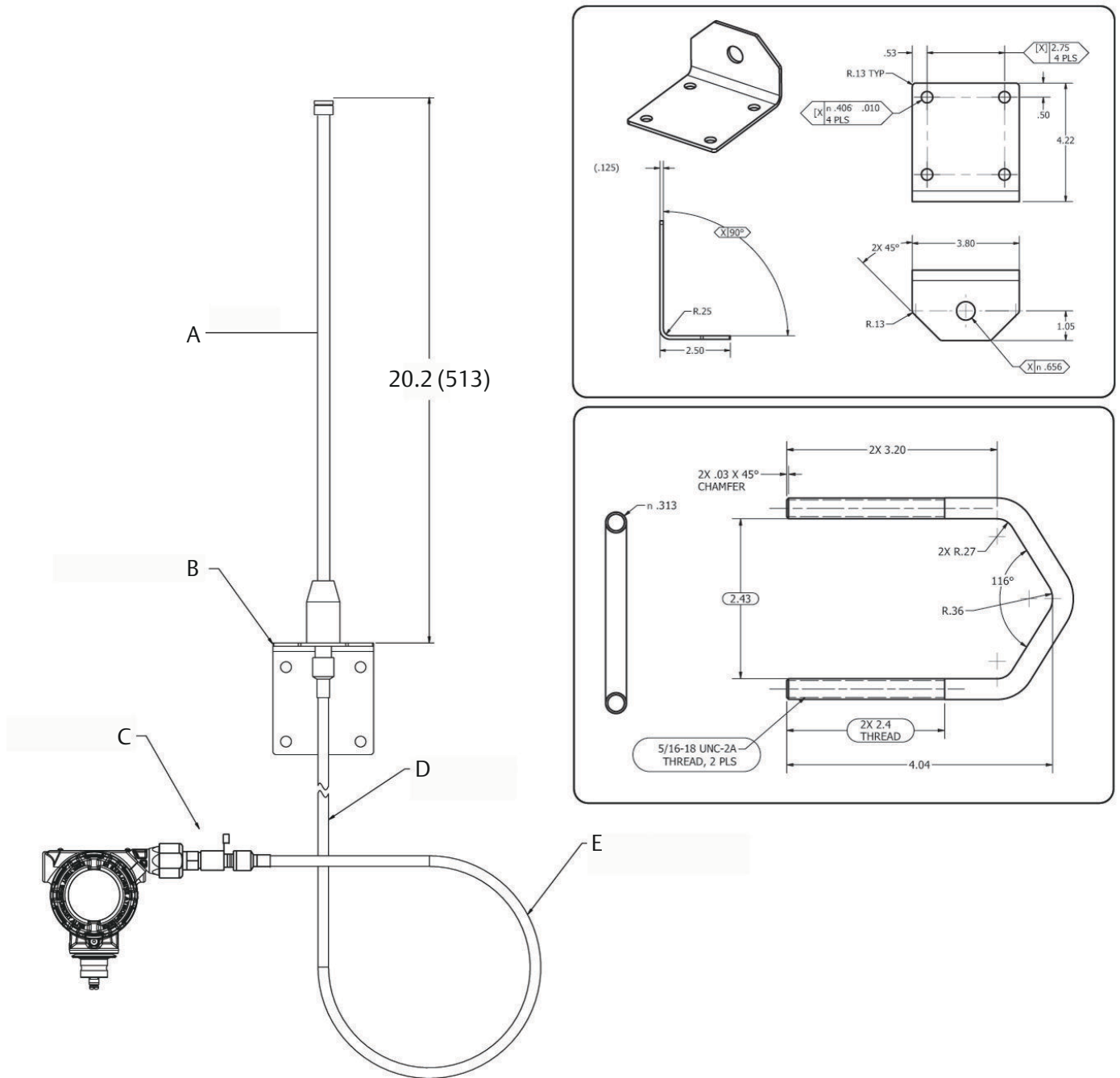
Figure 16: Plantweb Housing, Junction Box Housing, and Quick Connect with In-line SuperModule Platform



A. I-flange process connector

Dimensions are in inches (millimeters).

Figure 17: High Gain, Remote Mount Antenna (WN Option)

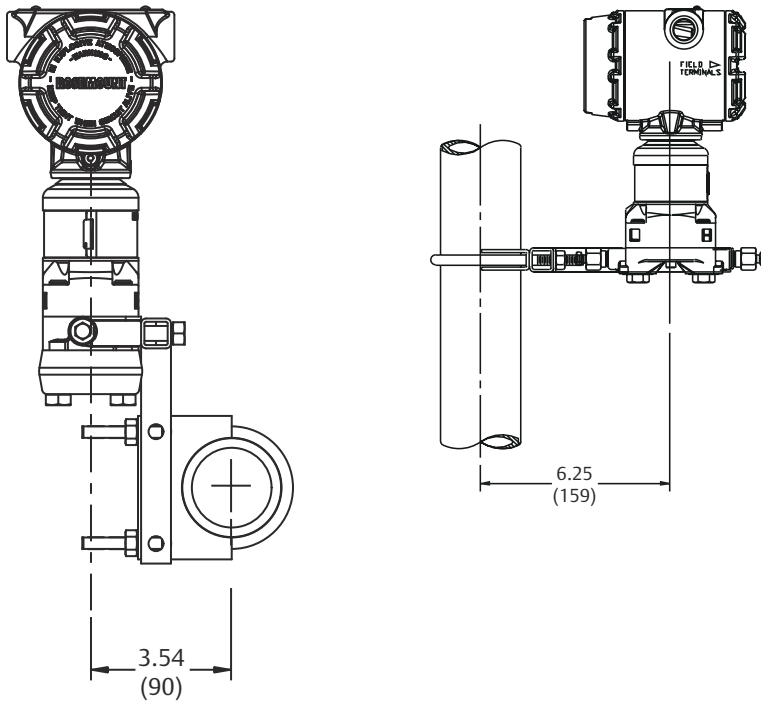


- A. Antenna
- B. Mounting bracket
- C. Lightning arrester
- D. 25 ft. (7.6 m) cable
- E. Min drip loop Ø12-in. (0.3 m)

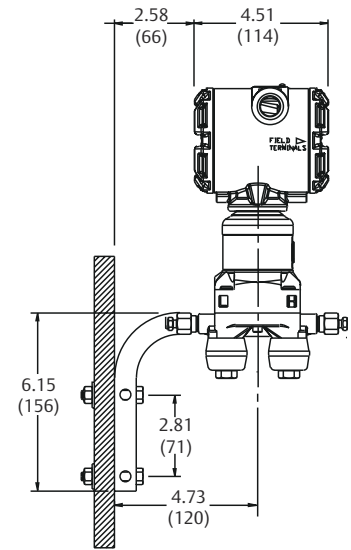
Dimensions are in inches (millimeters).

**Figure 18: Coplanar Mounting Configurations (B4 Bracket)**

Pipe mount (front and side views)



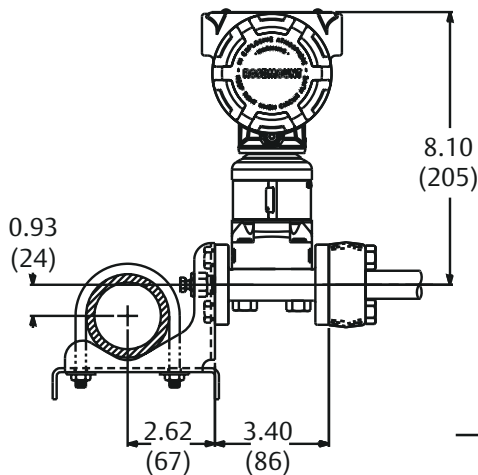
Panel mount (side view)



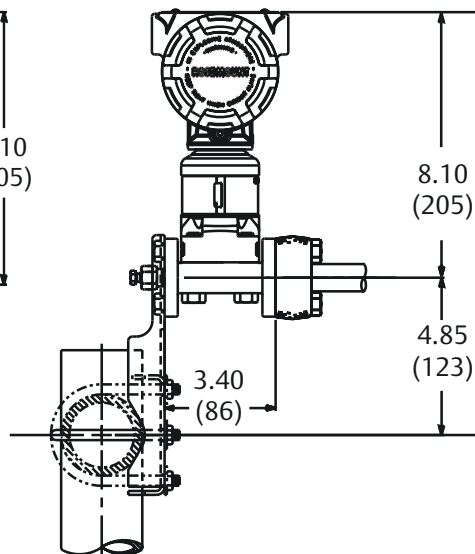
Dimensions are in inches (millimeters).

**Figure 19: Traditional Mounting Configurations**

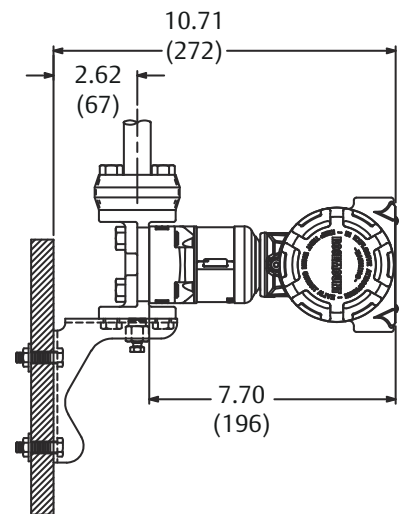
Pipe mount



Pipe mount (flat bracket)



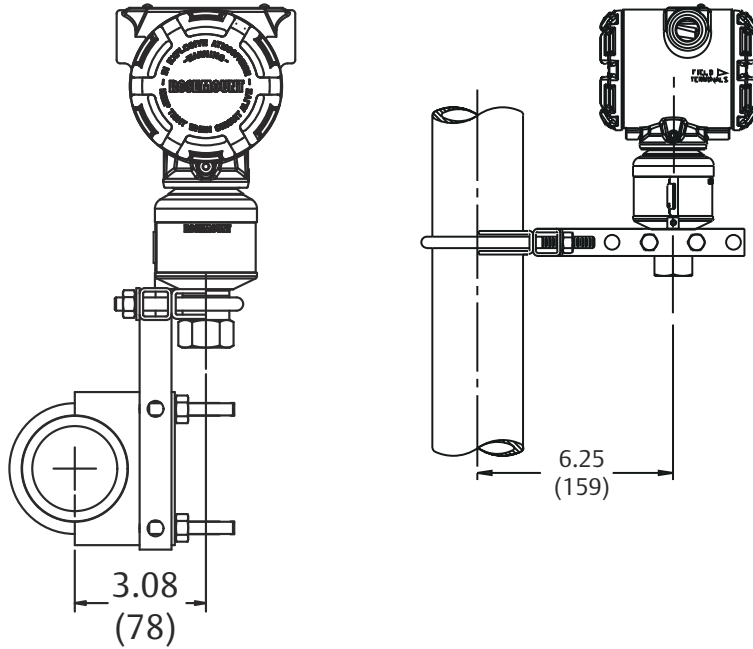
Panel mount



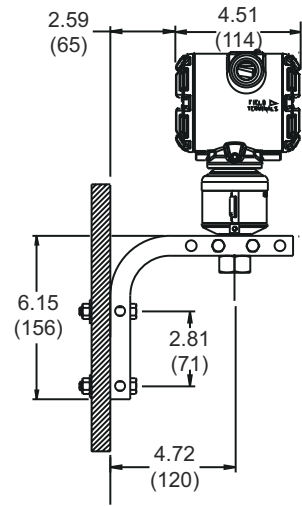
Dimensions are in inches (millimeters).

**Figure 20: In-line Mounting Configurations (B4 Bracket)**

Pipe mount (front and side views)



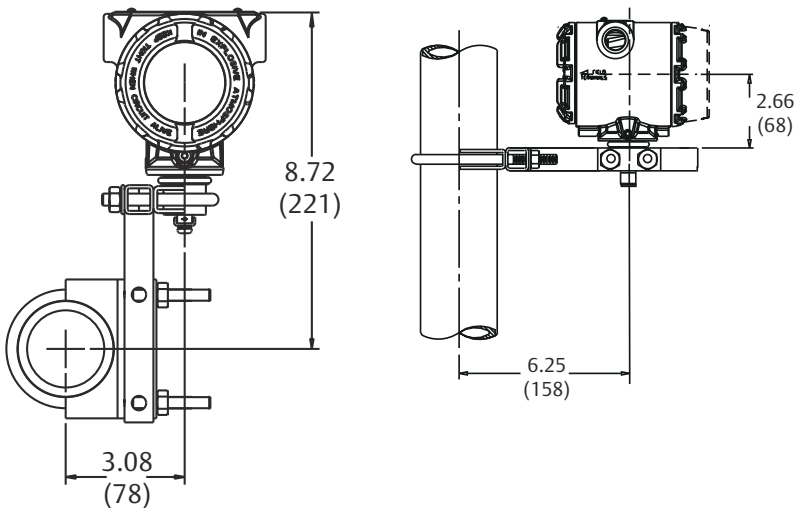
Panel mount (side view)



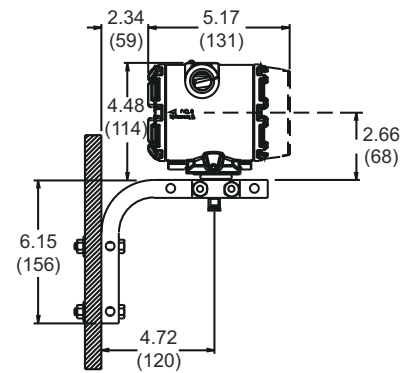
Dimensions are in inches (millimeters).

**Figure 21: Remote Display Mounting Configurations (B4 Bracket)**

Pipe mount (front and side views)



Panel mount (side view)

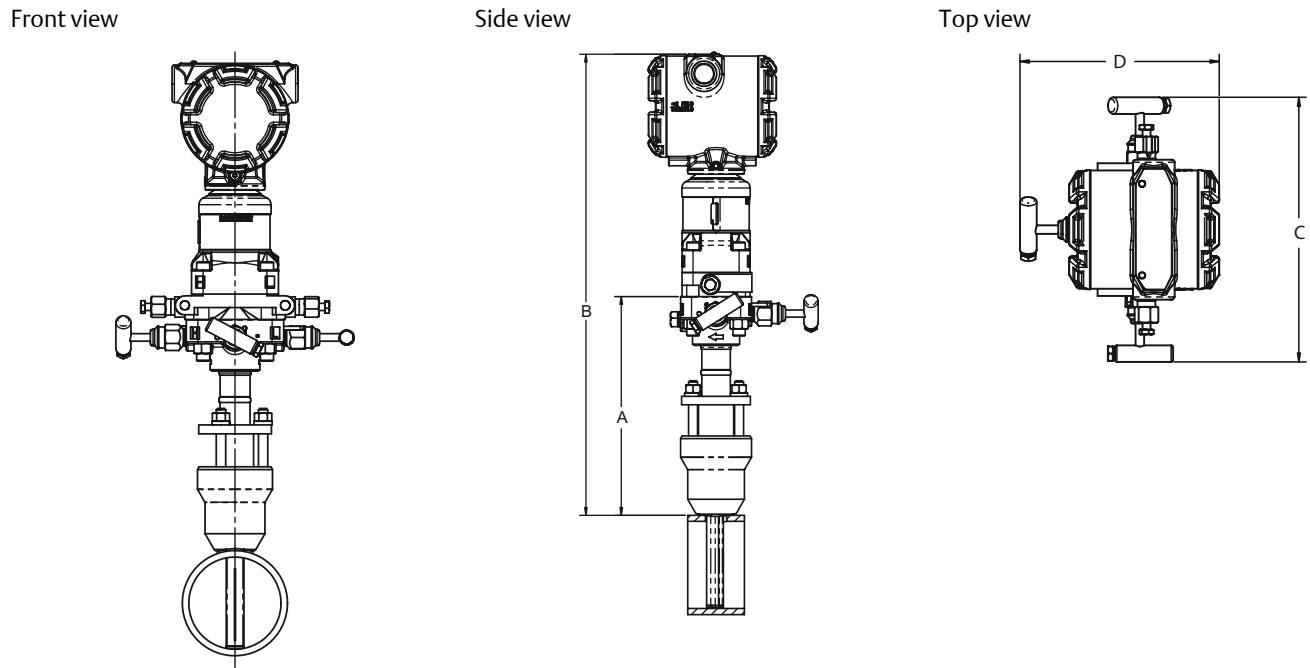


Dimensions are in inches (millimeters).

**Figure 22: Rosemount 3051SFA Annubar Flow Meter**

**Note**

The Pak-Lok Annubar model is available up to Class 600 ANSI (1440 psig at 100 °F [99 bar at 38 °C]).



**Table 44: Rosemount 3051CFA Annubar Flow Meter Dimensional Data**

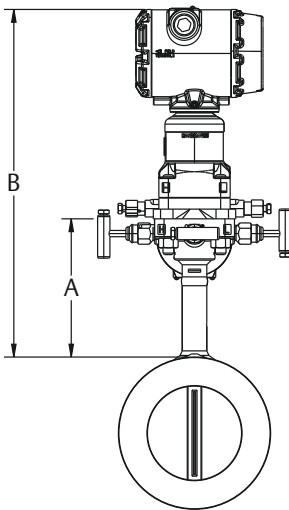
Sensor size	A (Max)	B (Max)	C (Max)	D (Max)
1	8.50 (215,9)	17.10 (434,3)	8.66 (220,0)	7.00 (177,8)
2	11.00 (279,4)	19.60 (497,8)	8.66 (220,0)	7.00 (177,8)
3	12.00 (304,8)	20.60 (523,2)	8.66 (220,0)	7.00 (177,8)

Dimensions are in inches (millimeters).

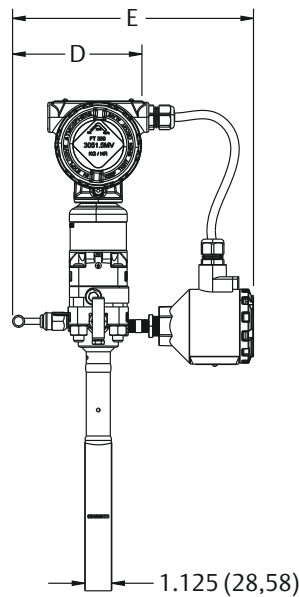


**Figure 23: Rosemount 3051SFC Compact Orifice Flow Meter (Primary Element Type code A)**

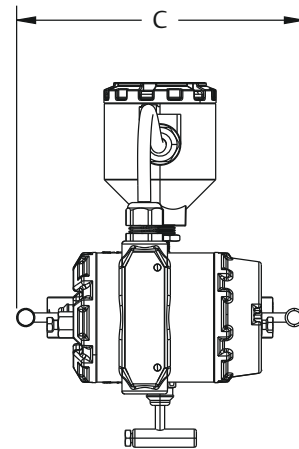
Front view (orifice plate)



Side view (orifice plate)



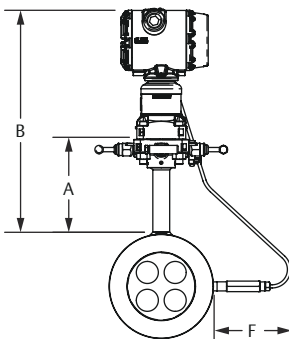
Top view (orifice plate)



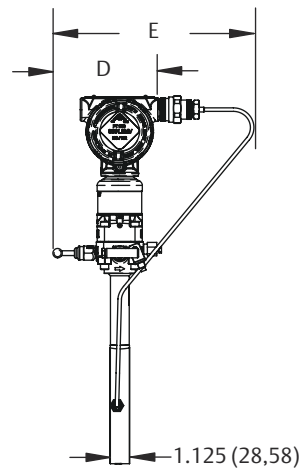
Dimensions are in inches (millimeters).

**Figure 24: Rosemount 3051SFC Compact Orifice Flow Meter (Primary Element Type code C and P)**

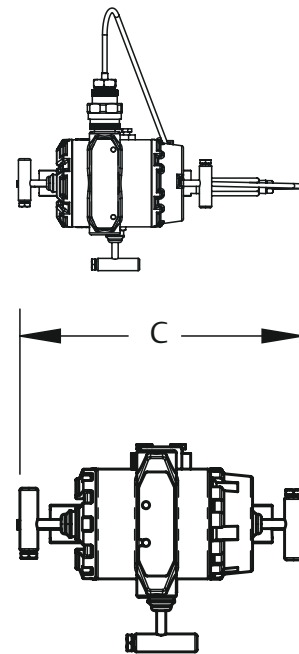
Front view (orifice plate)



Side view (orifice plate)



Top view (orifice plate)



Dimensions are in inches (millimeters).

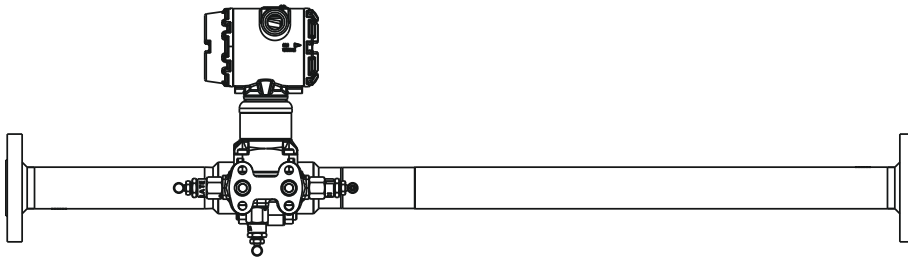
**Table 45: Rosemount 3051SFC Compact Orifice Flow Meter Dimensional Data**

Primary element type	A	B	Transmitter height	C	D	E	F
Type A	5.62 (143)	Transmitter Height + A	8.53 (217)	7.75 (197) - closed 8.25 (210) - open	6.00 (152) - closed 6.25 (159) - open	10.0 (254) - closed 10.25 (260,3) - open	N/A
Type P and C	5.62 (143)	Transmitter Height + A	7.70 (196)	7.75 (197) - closed 8.25 (210) - open	6.00 (152) - closed 6.25 (159) - open	10.2 (257,8) - closed 10.4 (26,2) - open	Max of 7.2 (184)

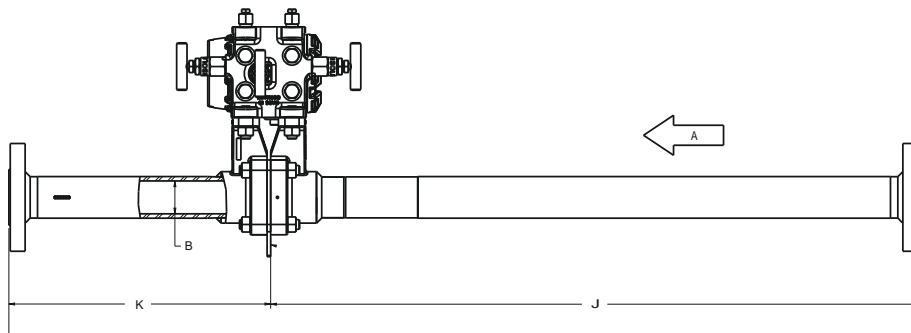
Dimensions are in inches (millimeters).

**Figure 25: Rosemount 3051SFP Integral Orifice Flow Meter**

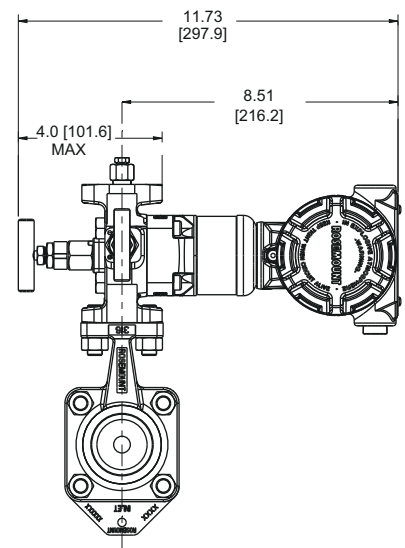
Front view



Bottom view



Side view



- A. Direction of flow
- B. Bore diameter (B.D.)
- C. 2x ¼-in. NPT vent valves
- K. Downstream dimension (including orifice plate)
- J. Upstream dimension

Dimensions are in inches (millimeters).

**Table 46: Rosemount 3051SFP Integral Orifice Flow Meter Dimensional Data**

Dimension	Line size		
	½-in. (15 mm)	1-in. (25 mm)	1½-in. (40 mm)
J (Beveled/Threaded pipe ends)	12.54 (318,4)	20.24 (514,0)	28.44 (722,4)

**Table 46: Rosemount 3051SFP Integral Orifice Flow Meter Dimensional Data (continued)**

J (RF slip-on, RTJ slip-on, RF-DIN slip on)	12.62 (320,4)	20.32 ( 516,0)	28.52 (724,4)
J (RF Class 150, weld neck)	14.37 (364,9)	22.37 (568,1)	30.82 (782,9)
J (RF Class 300, weld neck)	14.56 (369,8)	22.63 (574,7)	31.06 (789,0)
J (RF Class 600, weld neck)	14.81 (376,0)	22.88 (581,0)	31.38 (797,1)
K (Beveled/Threaded pipe ends)	5.74 (145,7)	8.75 (222,2)	11.91 (302,6)
K (RF slip-on, RTJ slip-on, RF-DIN slip on) <sup>(1)</sup>	5.82 (147,8)	8.83 (224,2)	11.99 (304,6)
K (RF Class 150, weld neck)	7.57 (192,3)	10.88 (276,3)	14.29 (363,1)
K (RF Class 300, weld neck)	7.76 (197,1)	11.14 (282,9)	14.53 (369,2)

(1) Downstream length shown here includes plate thickness of 0.162-in. (4,11 mm).

**Figure 26: Rosemount 3051S Scalable Level Transmitter with FF Seal**

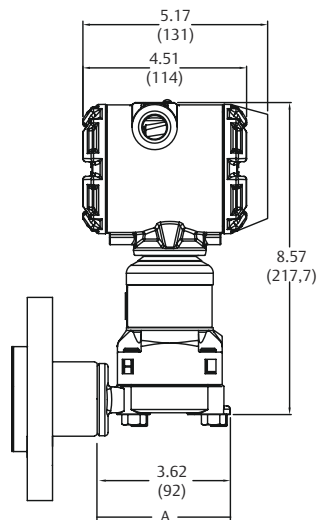
**Note**

Seal dimensions and pressure ratings can be found in the Rosemount DP Level Transmitters and 1199 Remote Seals [Product Data Sheet](#).

**Note**

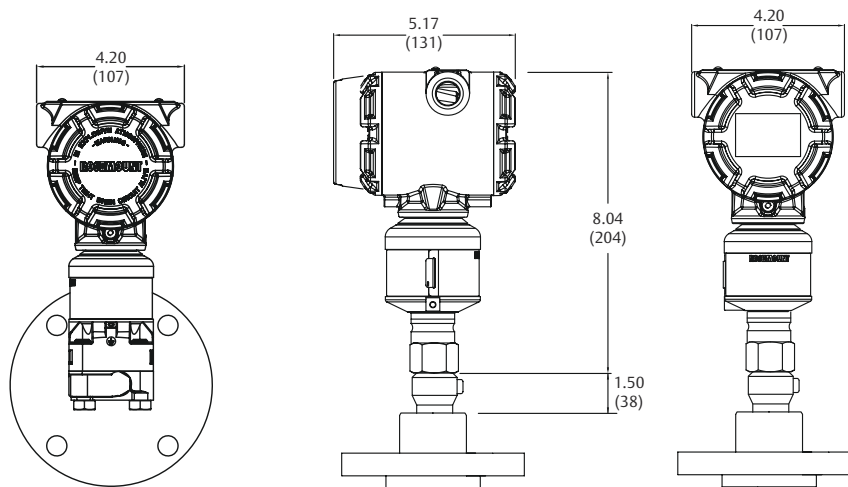
Lower housing (flushing ring) is available with FFW style flange.

Coplanar



A. + Direct mount extension length

In-line



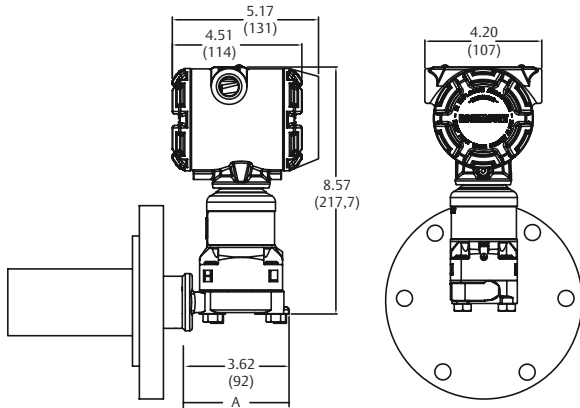
Dimensions are in inches (millimeters).

**Figure 27: Rosemount 3051S Scalable Level Transmitter with EF Seal**

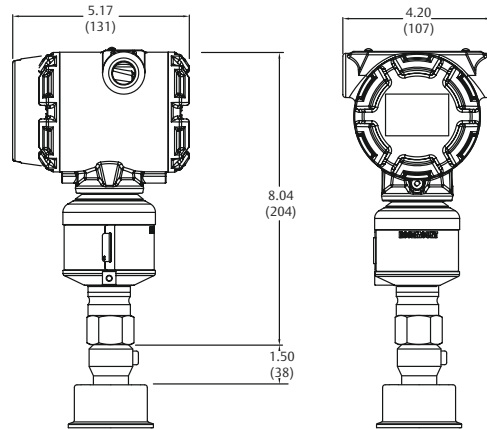
**Note**

Seal dimensions and pressure ratings can be found in the Rosemount DP Level Transmitters and 1199 Remote Seals [Product Data Sheet](#).

Coplanar



In-line



A. + Direct mount extension length

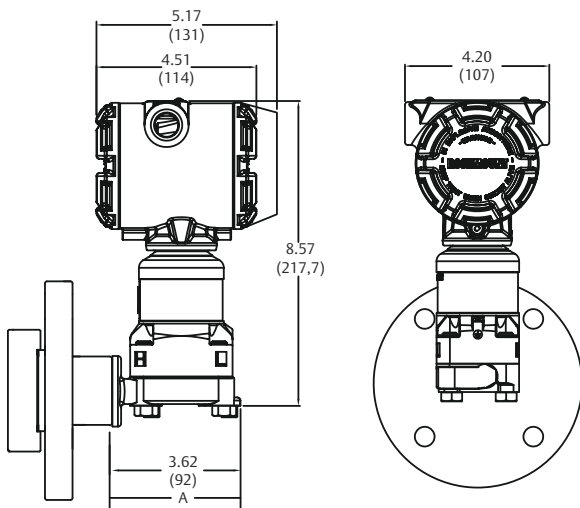
Dimensions are in inches (millimeters).

**Figure 28: Rosemount 3051S Scalable Level Transmitter with RF Seal**

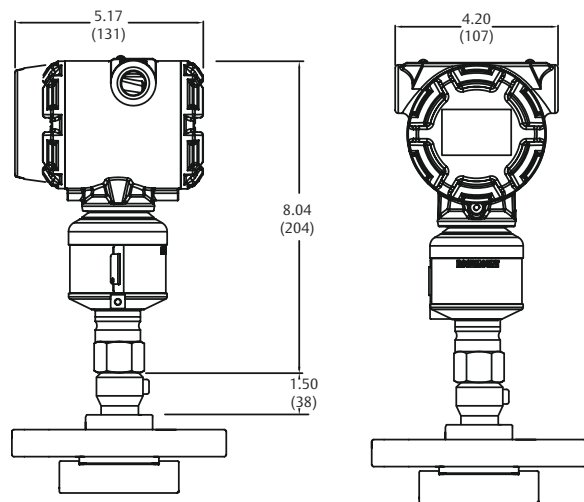
**Note**

Seal dimensions and pressure ratings can be found in the Rosemount DP Level Transmitters and 1199 Remote Seals [Product Data Sheet](#).

Coplanar



In-line



A. + Direct mount extension length

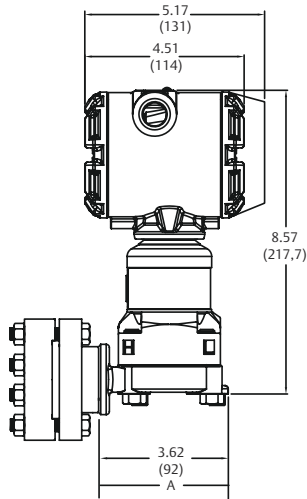
Dimensions are in inches (millimeters).

**Figure 29: Rosemount 3051S Scalable Level Transmitter with RT Seal**

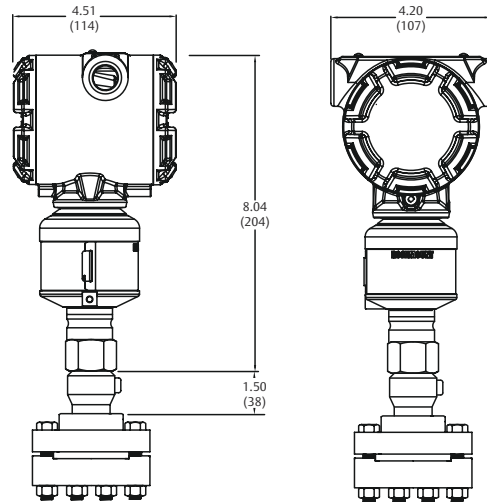
**Note**

Seal dimensions and pressure ratings can be found in the Rosemount DP Level Transmitters and 1199 Remote Seals [Product Data Sheet](#).

Coplanar



In-line



A. + Direct mount extension length

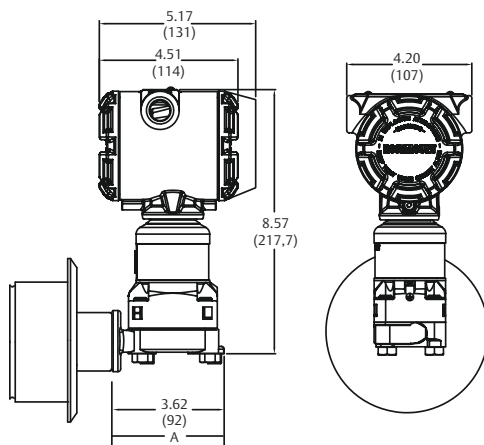
Dimensions are in inches (millimeters).

**Figure 30: Rosemount 3051S Scalable Level Transmitter with SS Seal**

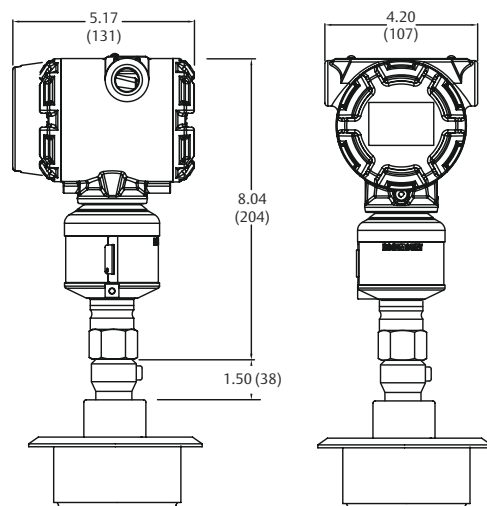
**Note**

Seal dimensions and pressure ratings can be found in the Rosemount DP Level Transmitters and 1199 Remote Seals [Product Data Sheet](#).

Coplanar



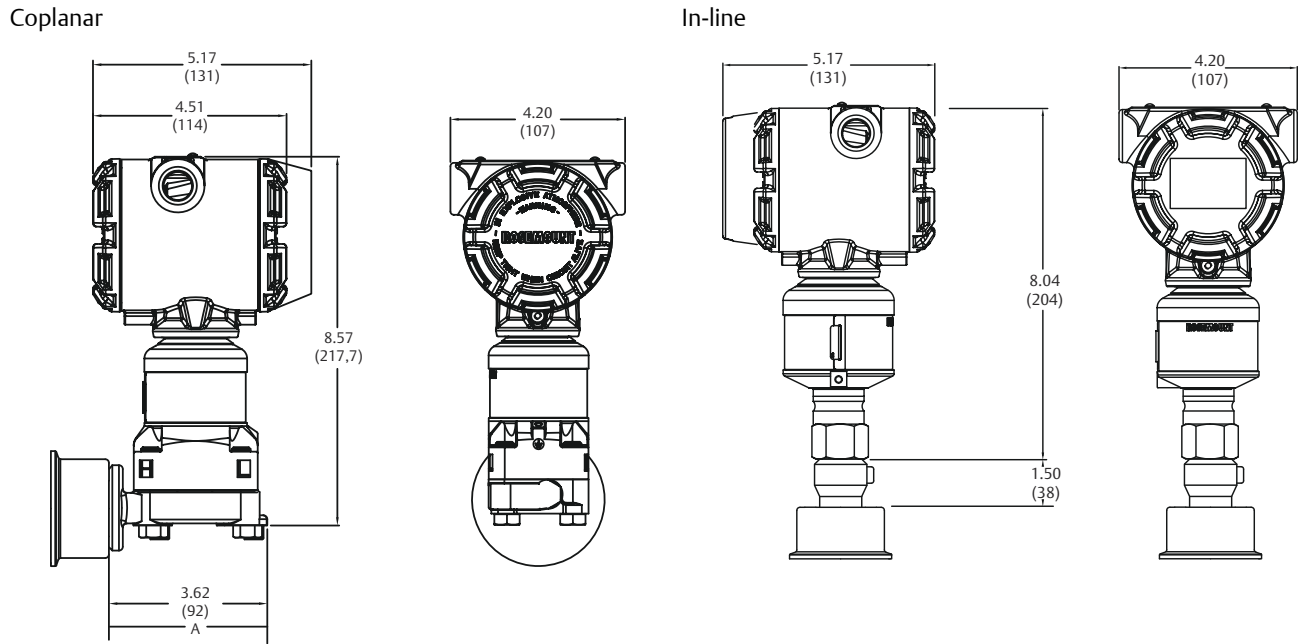
In-line



A. + Direct mount extension length

Dimensions are in inches (millimeters).

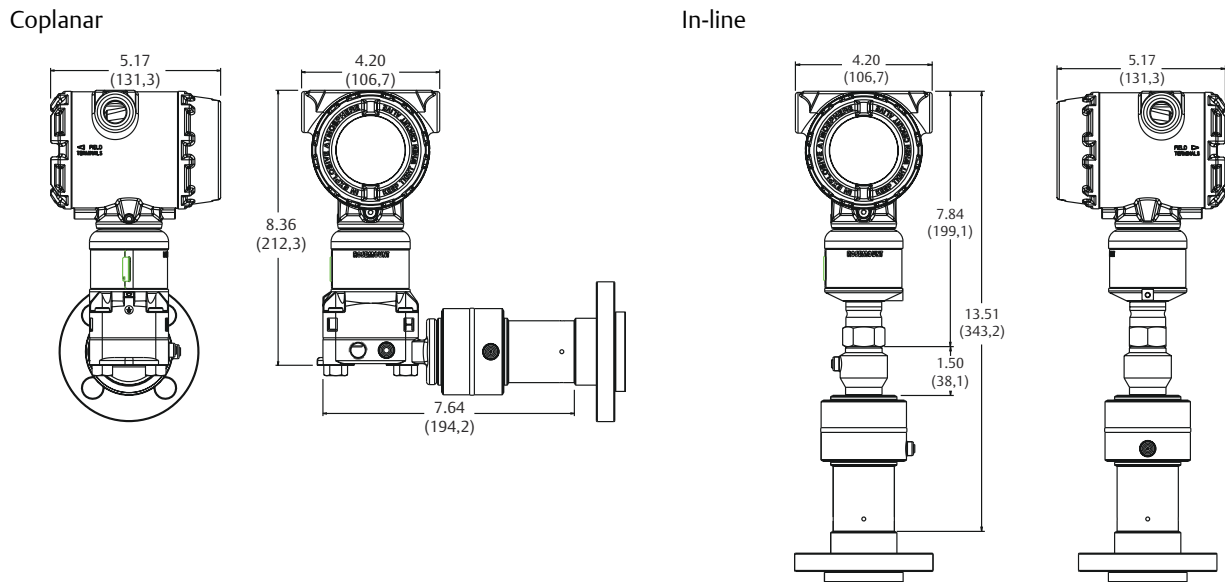
**Figure 31: Rosemount 3051S Scalable Level Transmitter with SC Seal**



A. + Direct mount extension length

Dimensions are in inches (millimeters).

**Figure 32: Rosemount 3051S Scalable Level Transmitter with Thermal Range Expander**



Dimensions are in inches (millimeters).

## Accessories

### Rosemount Engineering Assistant (EA) software packages

The Rosemount Engineering Assistant software supports flow configuration for the Rosemount 3051SMV. The package is available with or without modem and connecting cables. All configurations are packaged separately. For best performance of the EA software, the following computer hardware and software is recommended:

#### Note

Engineering Assistant version 6.1 or later requires the use of Microsoft® .NET Framework version 2.0 or later. If .NET version 2.0 is not currently installed, the software will be automatically installed during the Engineering Assistant installation. Microsoft.NET version 2.0 requires an additional 200 MB of disk space.

#### Minimum system requirements for Engineering Assistant 5.5.1 for the Rosemount 3051SMV FOUNDATION Fieldbus with fully compensated mass flow block

- Intel® Core™ Duo, 2.4 GHz
- Operating System: Windows™ 7, 32- or 64-bit
- 600 MB of available hard disk space
- USB port

#### Minimum system requirements for Engineering Assistant 6 for the Rosemount 3051SMV HART device

- Pentium®-grade Processor: 500 MHz or faster
- Operating System: Microsoft Windows 2000 (32-bit), Windows XP Professional (32-bit), Windows 7, or Windows 8
- 256 MB RAM
- 100 MB of available hard disk space
- RS232 serial port or USB port (for use with HART® modem)
- CD-ROM

**Table 47: Engineering Assistant Software Packages**

Code	Product description
EA	Engineering Assistant Software Program
<b>Software media</b>	
2	EA Rev. 5 (Compatible with Rosemount 3051SMV FOUNDATION Fieldbus, Rosemount 3095, and Rosemount 333)
3	EA Rev. 6 (Compatible with Rosemount 3051SMV HART only)
<b>Language</b>	
E	English
<b>Modem and connecting cables</b>	
0	None
H	Serial port HART modem and cables
B	USB port HART modem and cables
<b>License</b>	
N1	Single PC license
N2	Site license

Table 47: Engineering Assistant Software Packages (continued)

Code	Product description
Typical model number: EA 2 E 0 N1	

**Accessories**

Item description	Part number
Serial port HART modem and cables only	03095-5105-0001
USB port HART modem and cables only <sup>(1)</sup>	03095-5105-0002
Long-life power module for Wireless option	701PBKKF

(1) Supported by SNAP-ON™ EA with AMS Device Manager version 6.2 or higher.









©2021 Emerson. All rights reserved.

Emerson Terms and Conditions of Sale are available upon request. The Emerson logo is a trademark and service mark of Emerson Electric Co. Rosemount is a mark of one of the Emerson family of companies. All other marks are the property of their respective owners.

**ROSEMOUNT™**

